

# EFFYDESK

## Instruction Manual

### Technical Data

|                |            |               |        |
|----------------|------------|---------------|--------|
| Segment Column | 3          | Input Voltage | 110V   |
| Maximum Load   | 300 lbs    | Speed         | 35mm/s |
| Recommend Load | < 240 lbs  | Certification | UL     |
| Height Range   | 24" to 50" |               |        |

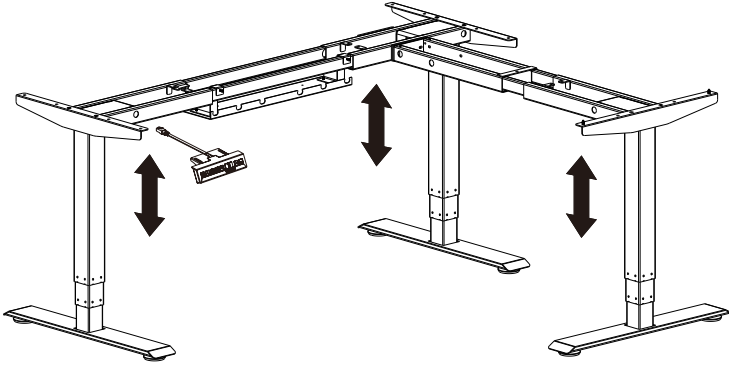

### Accessory List

Included in Executive Frame Package

|                            |                     |                               |                         |
|----------------------------|---------------------|-------------------------------|-------------------------|
| <b>Ax12</b><br>M6X12       | <b>Bx8</b><br>M6X8  | <b>Cx19</b><br>M5X18 or M6X16 | <b>Dx10</b><br>Zip Ties |
| <b>Ex19</b><br>Rubber Pads | <b>Fx2</b><br>M4X12 | <b>Gx12</b><br>M6X16          | <b>Hx6</b><br>M4X10     |
| <b>Ix16</b><br>M8X10       |                     | <b>Hangers*2</b>              |                         |

### Tool Required

|                          |                          |
|--------------------------|--------------------------|
|                          |                          |
| 3mm Allen Key (Included) | 4mm Allen Key (Included) |
|                          |                          |
| Tape Measure             | Screwdriver              |

Included In Executive Table top Package

|                  |          |
|------------------|----------|
|                  |          |
| Mending Plates*2 | M5X20*12 |

### Parts List

| No. | Control Box | Qty |
|-----|-------------|-----|
| ①   |             | 1   |

| No. | Power Cable | Qty |
|-----|-------------|-----|
| ②   |             | 1   |

| No. | Lifting Column | Qty |
|-----|----------------|-----|
| ③   |                | 3   |

| No. | Foot | Qty |
|-----|------|-----|
| ④   |      | 3   |

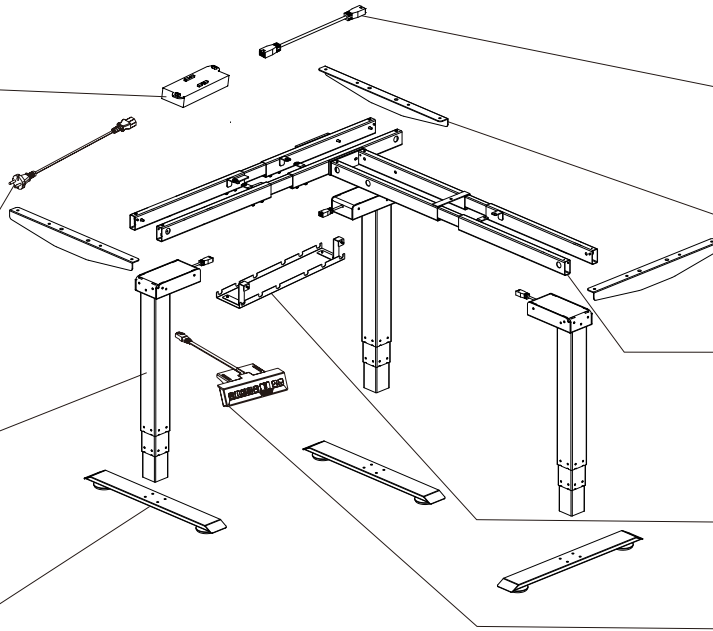

| No. | Extension Cord | Qty |
|-----|----------------|-----|
| ⑤   |                | 2   |

| No. | Side Bracket | Qty |
|-----|--------------|-----|
| ⑥   |              | 3   |

| No. | Crossbar | Qty |
|-----|----------|-----|
| ⑦   |          | 2   |

| No. | Cable Tray | Qty |
|-----|------------|-----|
| ⑧   |            | 1   |

| No. | Keypad | Qty |
|-----|--------|-----|
| ⑨   |        | 1   |

Thank you for your order!

If you have any issues with your product, please feel free to contact us via

[team@effydesk.ca](mailto:team@effydesk.ca) or [info@effydesk.ca](mailto:info@effydesk.ca) We will help you resolve the issue as soon as possible.

For more information, please visit

<https://effydesk.ca/pages/how-to-assemble-your-height-adjustable-standing-desk>

### STEP 1

Separate the Crossbar ⑦ and you will find the Crossbar Rail inside.

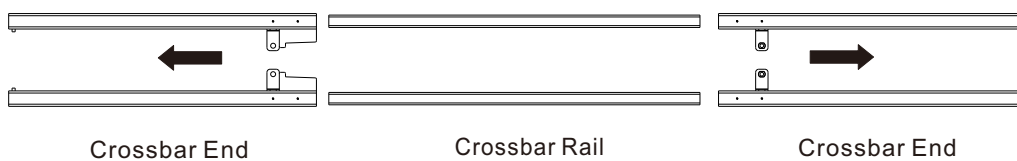

### STEP 2

Insert one of the Crossbar Ends into the one of the Lifting Columns ③ and secure with screws. Repeat the same step for the other Lifting Column.

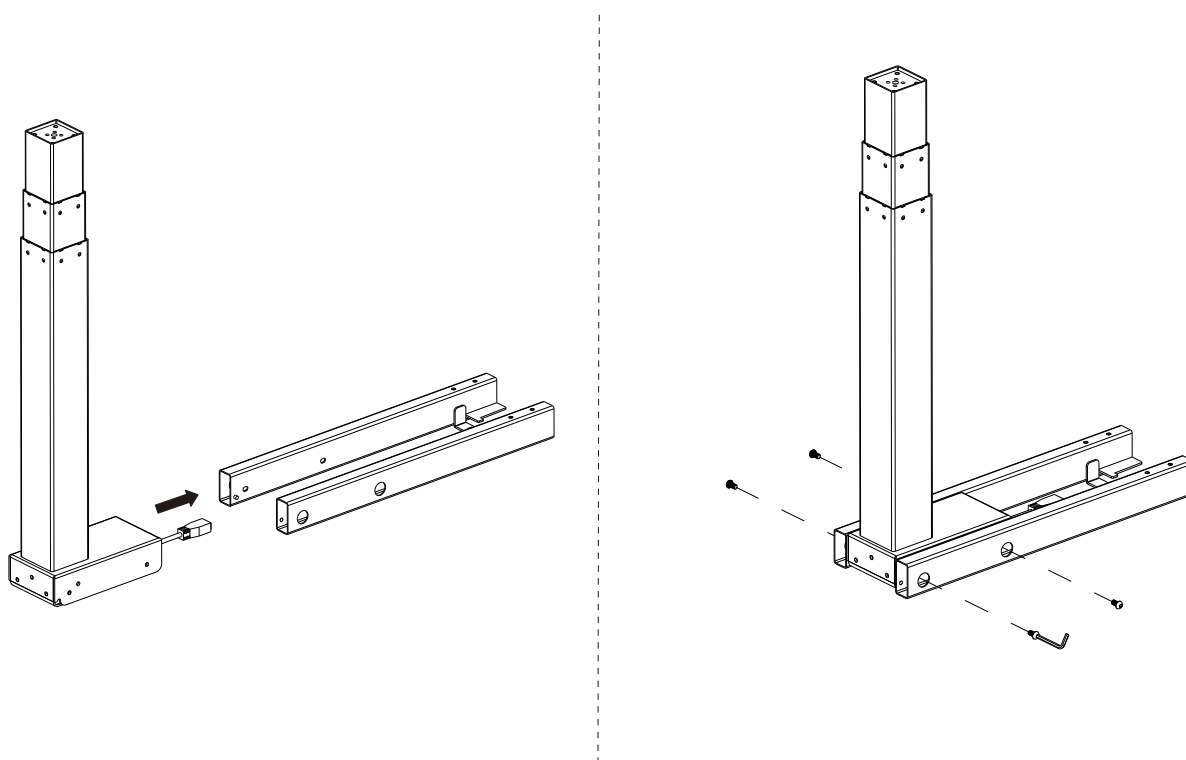

### STEP 3

Attach the Side Bracket ⑥ to one of the Lifting Columns. Repeat the same step for the other Lifting Column.

#### Step 2 Assembly

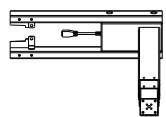

#### Side Bracket

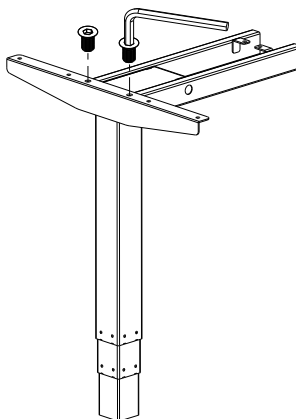
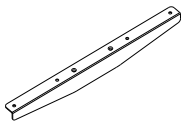

### STEP 4

Attach the Crossbar as shown.

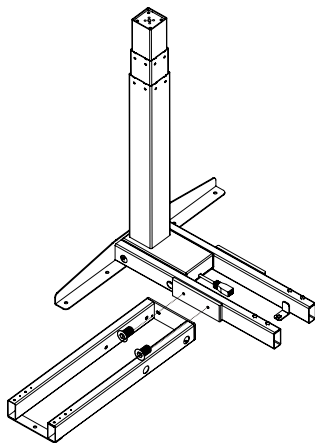
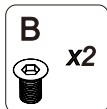

### STEP 5

Slide the Crossbar two Rails back into the Crossbar Ends. Please make sure to fit the slots as shown below.

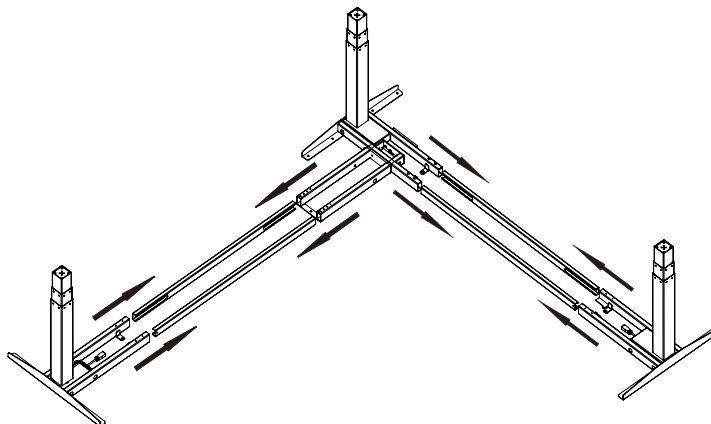

### STEP 6

Attach the Feet ④ to the bottom of the Lifting Columns.

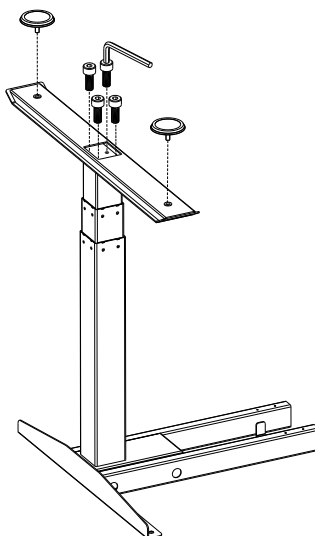
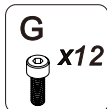

### STEP 7

Use the screws to tighten the Hangers onto the Crossbar.

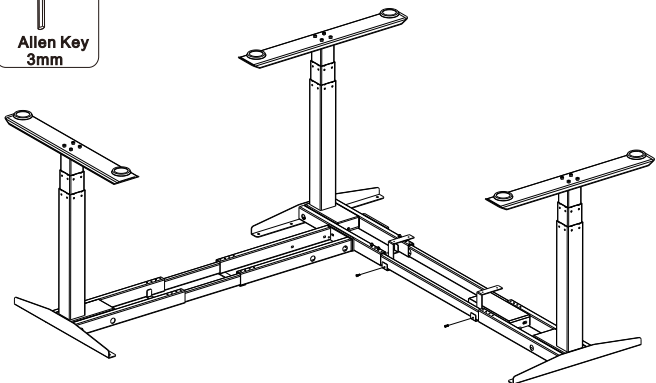

Note: The screws do not go through the Crossbar. Hangers, Allen Key and screws are found in a separate bag.

### STEP 8

Please note these parts are found in the table top package

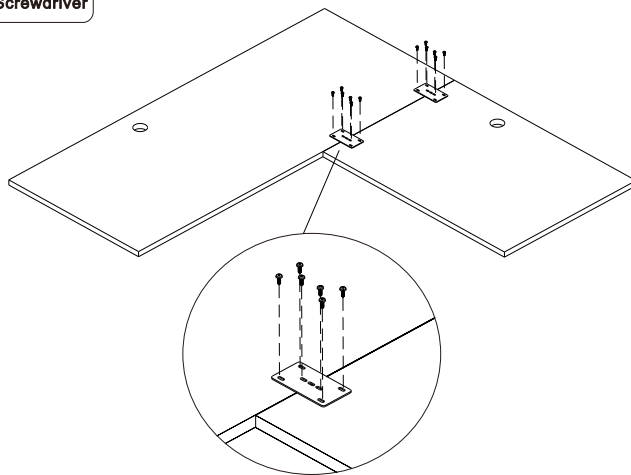

### STEP 9

Install the tabletop (Predrilled / Non-predrilled).

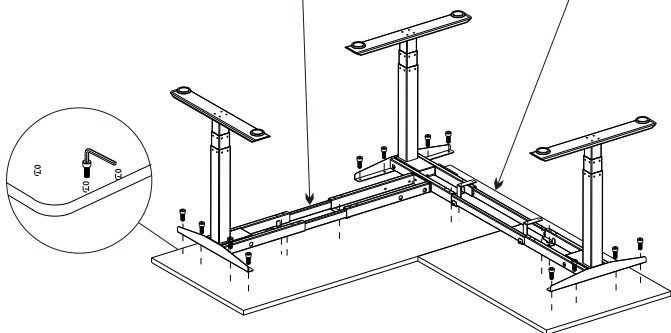
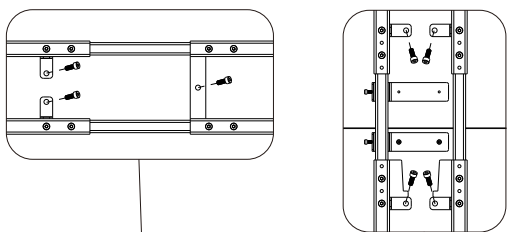
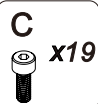

Predrilled

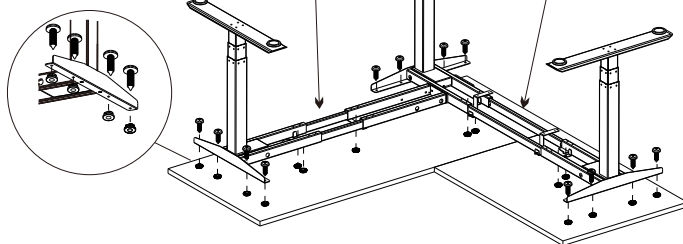
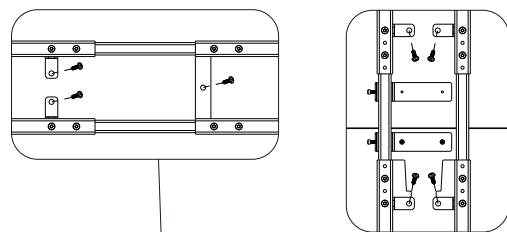

Non-predrilled

## STEP 10

Firmly secure the Crossbar with Screws (A) and connect all the cables to the Control Box ①.

I  
x16

D  
x10

Allen Key  
4mm

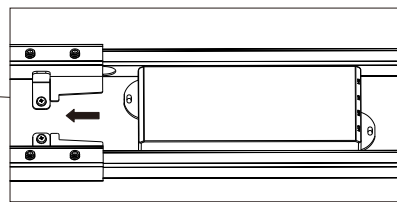
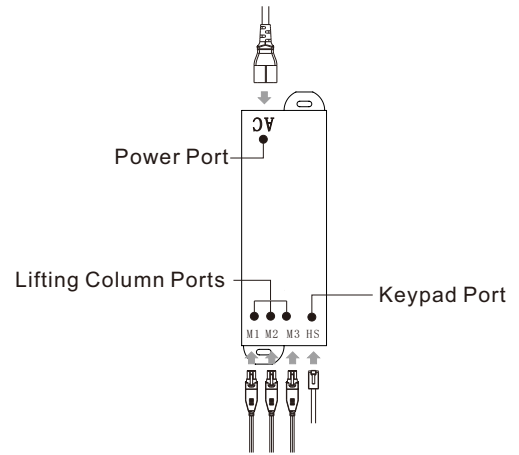
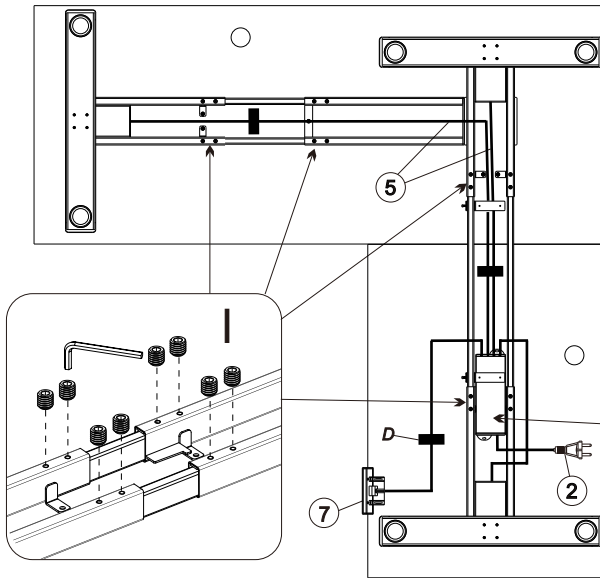

Note : Use Zip Ties (D) to secure cables under the table.

Slider for Control Box

## STEP 11

Attach the Cable Tray ⑧ to the Hangers with screws.

H  
x4

Allen Key  
3mm

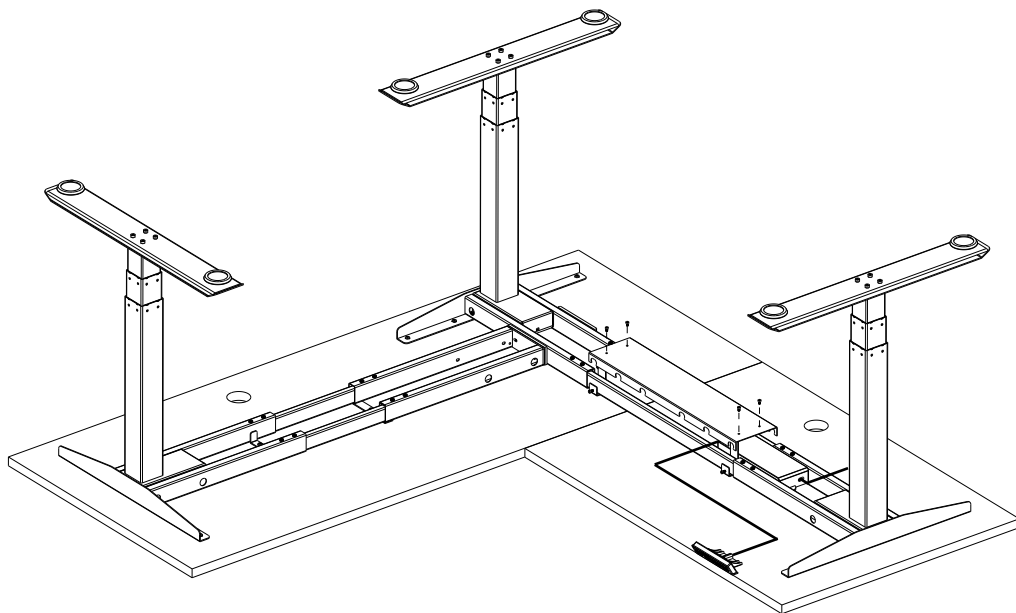

## STEP 12

Attach the Keypad ⑨ with Screws (F) to the tabletop.

F



x2



Screwdriver

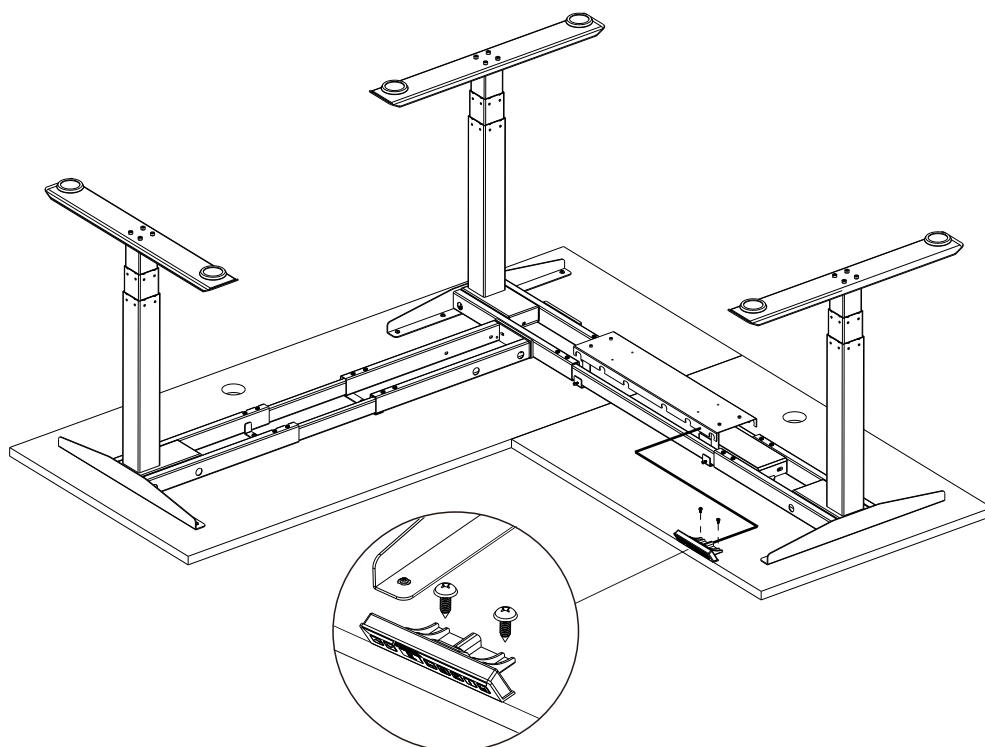

## STEP 13

Plug the cable from the Keypad into the Control Box and flip the table onto its feet.

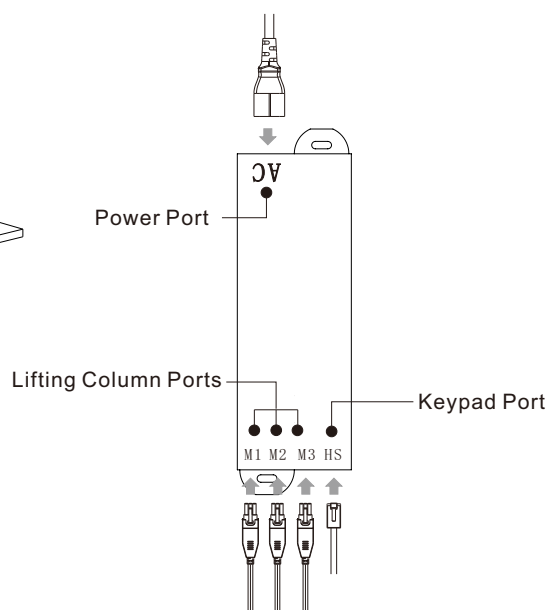
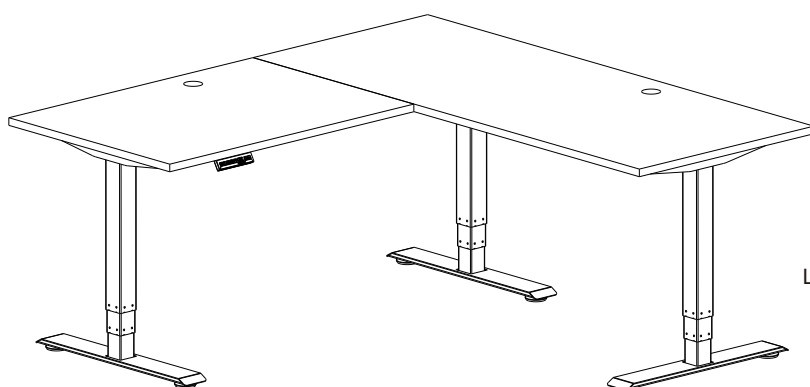

Note: The Control Box is equipped with a gyro sensor so the table and the Control Box must be level in order to work properly or else it will not move up and down.

# Prepare for First-time Use

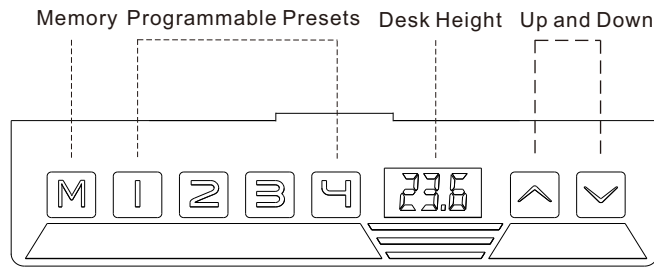

## **Before plugging in the table, make sure that:**

- The Lifting Columns are level and set at their lowest position.
- All the screws are tightened to avoid the desk from becoming wobbly.
- There is no object above or beneath the desk within its range of movement as it may result in physical damage.

## **Calibrate the desk by following the steps below:**

- Please press the Down button and hold for 10-15 seconds until the table stutters and beeps.
- Release the button. Your desk is ready to use!

# Operation Guide

## **Program Presets**

- Adjust the table to the desired height, then press M.
- “S-” will flash on the display.
- Press a number to set the desired height as a preset.

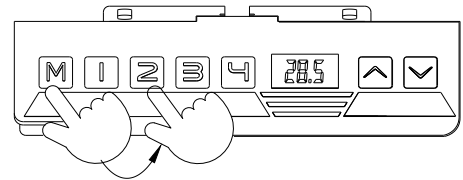

## **Set Stand Up Reminder**

- Press and hold the number 1 and 3 buttons at the same time.
- When display shows "0.0h", press the Up or Down arrows to adjust the reminder time by 30 minute (0.5 hr) increments.
- Once the display stops flashing, your reminder has been set.
- Repeat above steps to set another reminder for next time.

## **Advanced Safety Feature: Lock and unlock the table**

- Press the Up and Down buttons at the same time for 5 seconds, until “LOC” appears on the display.
- All buttons will be deactivated and no changes can be made.
- Press the Up and Down buttons together again to unlock the Keypad and all of the table’s features.

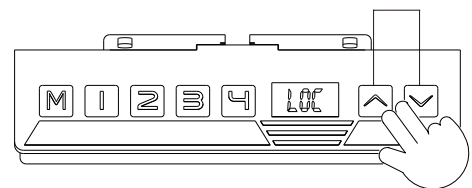

## **Set Maximum Height Limit**

- Raise the desk to the desired maximum height.
- Press M and the Up button together for 5 seconds until you hear a beep. This sets the maximum height limit.

## **Set Minimum Height Limit**

- Lower the desk to the desired minimum height.
- Press M and the Down button together for 5 seconds until you hear a beep. This sets the minimum height limit.

## **Changing from Centimetres to Inches**

- Press M for 10 seconds, the Keypad will display “1-1”.
- Press the Down button and it will change to “1-0”.
- Press M for 10 seconds to lock the setting.

## **Reset the table**

**When an error code or “RST” appears on the display, please reset the table.**

- Unplug the power cord from the Control Box.
- Unplug the cable that connects the Keypad to the Control Box.
- Wait 30 minutes and plug all the cables back in again.
- Press the Down button and hold for 10-15 seconds until the table stutters and beeps.

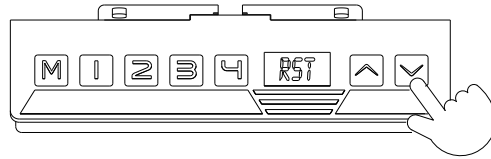

Press by holding  
10-15 seconds

## **If “HOT” appears on the display**

- Please unplug and replug and let it cool off for a couple of minutes before proceeding.

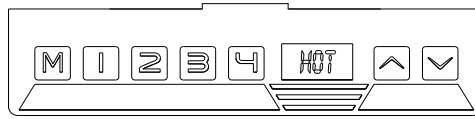



# EFFYDESK

If you have any questions, please contact us at

[team@effydesk.ca](mailto:team@effydesk.ca) or [info@effydesk.ca](mailto:info@effydesk.ca)

[www.effydesk.ca](http://www.effydesk.ca)