



0230-0214PL

PO BOX 4394
SANTA ROSA, CA
95402 USA

P (707) 525-9941
F (707) 575-7046
EMGPICKUPS.COM

**PASSIVE
PICKUP
INPUTS**

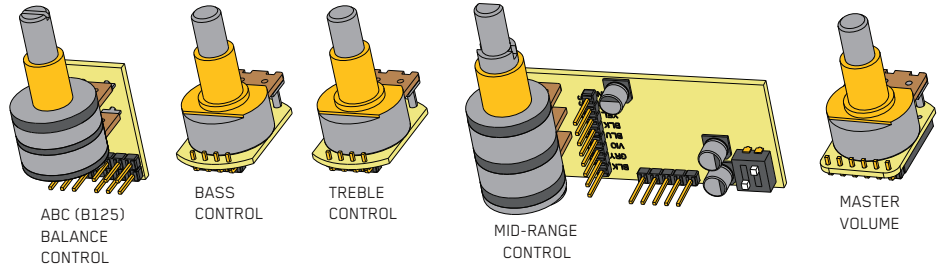

INSTALLATION INFORMATION EMG MODEL: BQS-HZ SYSTEM (PASSIVE PICKUP INPUT)

ABOUT THE BQS-HZ SYSTEM:

The BQS-HZ System is a complete control system for bass guitars. Active Balance, Master Volume and EQ circuits are included. The EQ effects are illustrated in the graphs on the next page. They allow you separate control over bass, midrange, and treble. Rotate the controls clockwise to boost, counterclockwise to cut. There is a center detent for flat response.

The mid-range control has a variable frequency knob that allows you to sweep through the mid-frequency range from 100Hz to 1KHz. This selects the frequency to boost or cut.

Included in the system are:

- 1) Active Balance Control (B125)

The B125 Active Balance Control is designed for Passive Pickups. It allows loss-free balance between two pickups and has a center detent for the middle position. If you are using EMG Active pickups you can also use the B125 although the B118 Active Balance Control which features inputs for Active Pickups has lower noise.

- 2) BQS Control 3-band equalizer for Bass guitar. The BQS features dual-pole filters for broadband equalization. The primary feature of the BQS System is the variable mid-range frequency selection from 100 to 1KHz along with boost or cut of the chosen frequency. An additional feature of the BQS Control is a 2-position dip-switch that controls the slope of the high frequency response. By choosing one of the four combinations the high frequency response can be tailored to your liking.

- 3) Master Volume control, output jack, battery buss and clip.

Specifications for each of the EMG products included in the BQS-HZ System are available online.

Go to: <http://www.emgpickups.com>

INSTALLATION NOTES:

BATTERY POWER:

If you play the instrument very hard, and are boosting the bass, mid, or treble with the BQS, you should consider operating the guitar on +18 Volts (2 Batteries in series, see page 4). If you play mildly and use a minimum of boost the instrument should operate easily on a single 9-Volt battery. Use an Alkaline or Lithium battery for the best battery life and always unplug your guitar when you're not using it.

WIRING ORDER:

Below is a diagram of the typical wiring order of the controls. Often the Volume control is closer to the pickups than the BQS Control making it difficult to wire the instrument. It is preferable to have the Master Volume control last in the signal chain before the output jack. If this isn't possible it's no worry, either wiring order is acceptable.

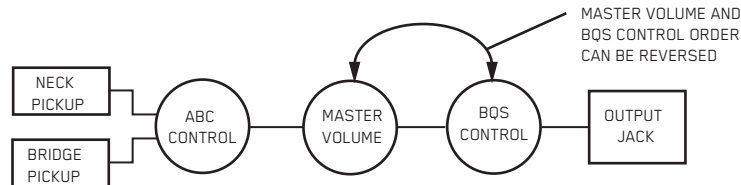

WARRANTY

All EMG Pickups and accessories are warranted for a period of two years. This warranty does not cover failure due to improper installation, abuse or damage. If upon examination the pickup is determined to be defective, a replacement will be made. Warranty replacement products are covered by this same warranty. This warranty covers only those pickups and accessories sold by authorized EMG Dealers. This warranty is not transferable.

© 2021 Copyright EMG INC. All Rights Reserved.

Installation Instructions:
EMG Model: BQS-HZ System

High Frequency (Treble) Response Selection:

The BQC has the added feature of allowing you to choose from 4 different high frequency response curves. This is a nice feature especially if you are using the BQC with passive pickups. The following diagrams show the dip-switch positions and the graphs show the resultant frequency response. The BQC Control is an equalizer style control, offering both boost and cut at the same frequency locations. The control also features a center detent (click) that lets you know when no equalization is in effect.

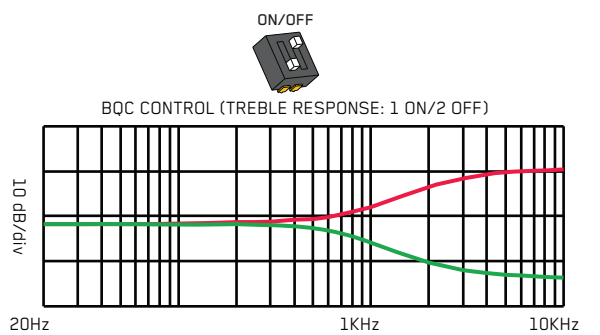
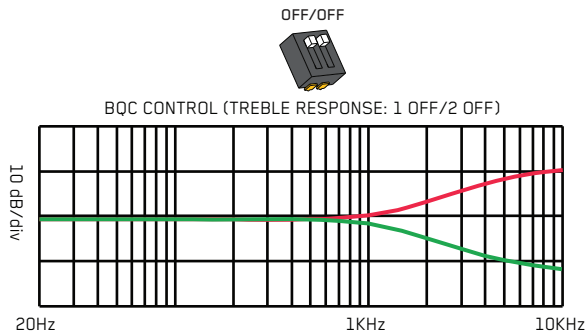
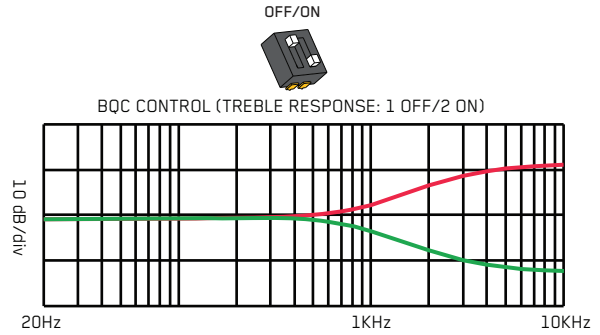
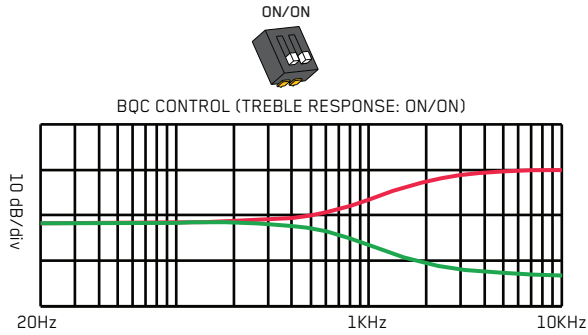
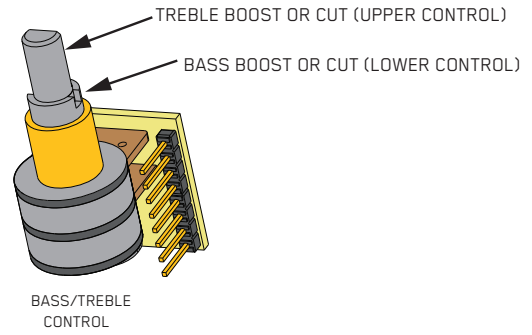

Low Frequency (Bass) Response:

The BQC has a fairly standard bass response boost and cut. It's slope is 6dB per octave and is centered at 50Hz. As you can see in the graph on the left the signal can be boosted by +12db (Red Line) or cut by -12dB (Green Line). A center detent (click) is provided on the control to let you know when the frequency response is flat or unaffected by boosting or cutting.

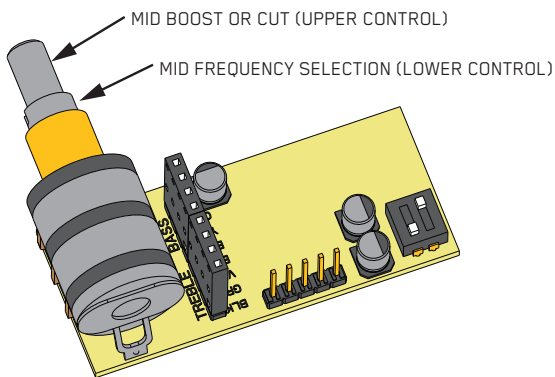
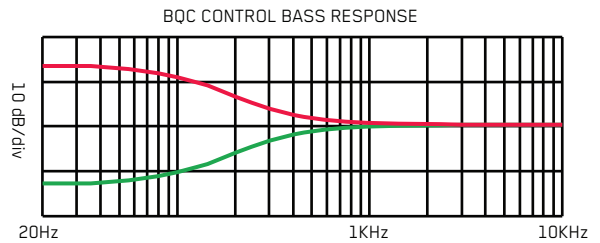

Mid-Range Frequency Response:

One of the primary features of the BQC is it's mid-range control. It allows you to choose the frequency you want to boost or cut from 100 to 1000 Hz. The concentric mid-range pot has two sections. The lower control chooses the frequency, while the upper control lets you choose the amount of boost or cut you want. The maximum slope is 12dB per octave at full gain or cut.. There is also a center detent (click) in the center of the upper control to let you know when the control is not having any effect.

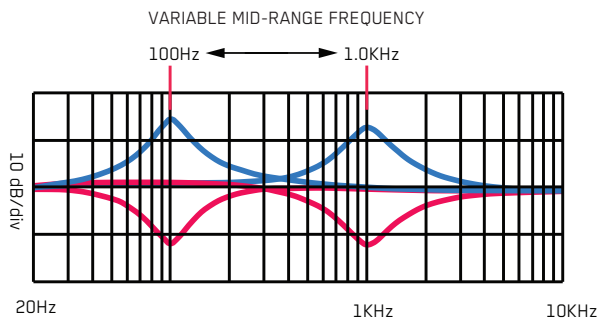

Installation Instructions:

Plug-in Pickup Inputs:

If you already have EMG Passive Pickups in your instrument you can use the existing pickup cables.
 Diagram #1 illustrates how to connect the pickups to the ABC Control by using the EMG plug-in connectors.

**Diagram #1
EMG-HZ Plug-in Inputs & Output**

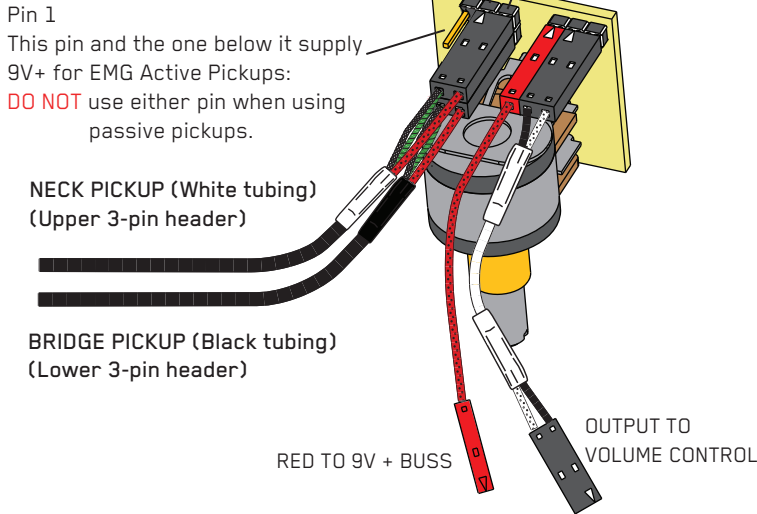

Soldered inputs:

On the back side of the ABC PC Board there are 4 pads to solder to. Solder the signal wire (Hot) of the bridge pickup to the BRG Pad, and solder the ground wire (shield) of that pickup to the GND Pad. Do the same for the Neck Pickup, Hot to the NEK Pad, and ground to the GND Pad.

**Diagram #2
EMG-HZ Pickups
Soldered Inputs**

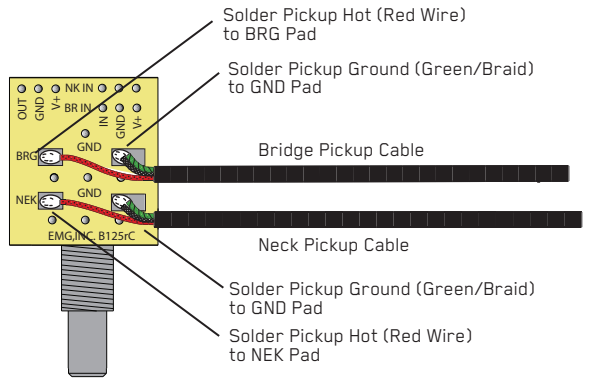

**Installation Instructions:
EMG Model: BQS-HZ System**

**Diagram #3 (preferred wiring order)
ABC Control
BQS Control
Master Volume
Output Jack**

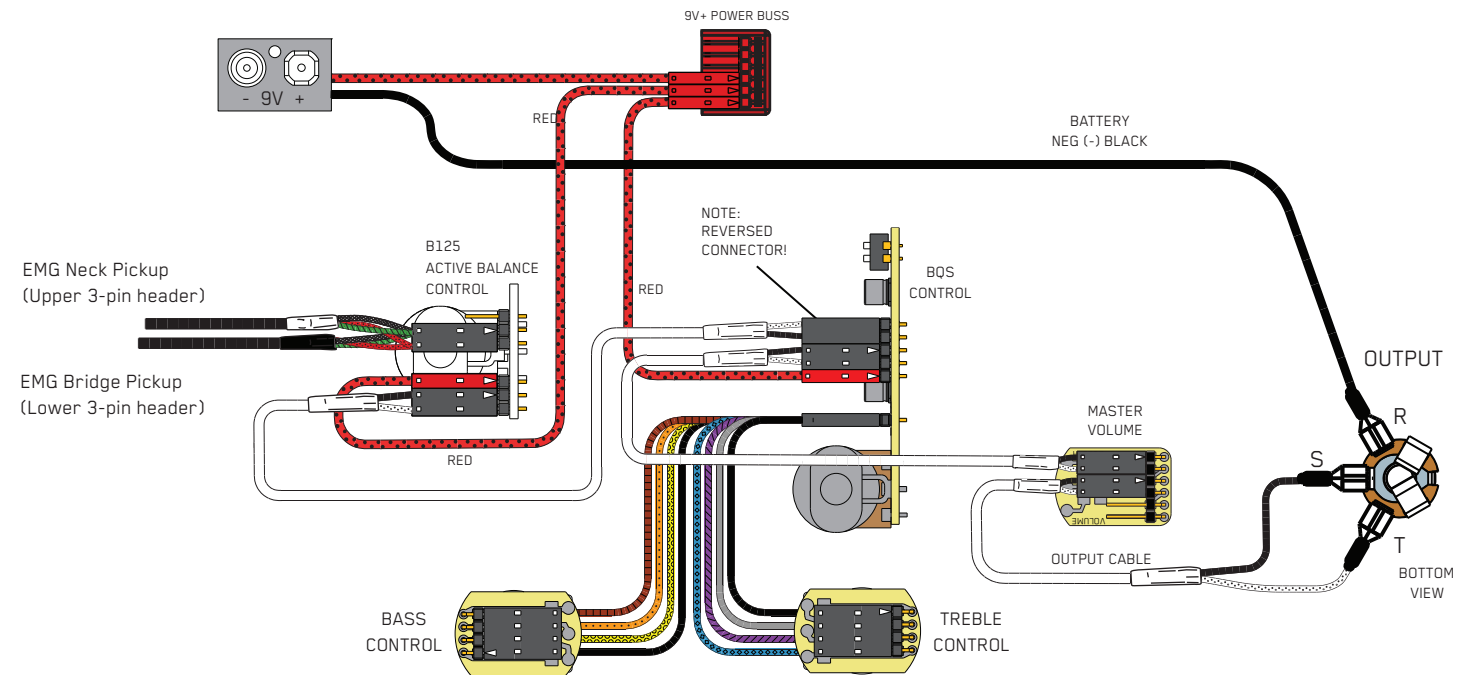

Diagram #4 (alternate wiring order)

ABC
Master Volume
BQC Control
Output Jack

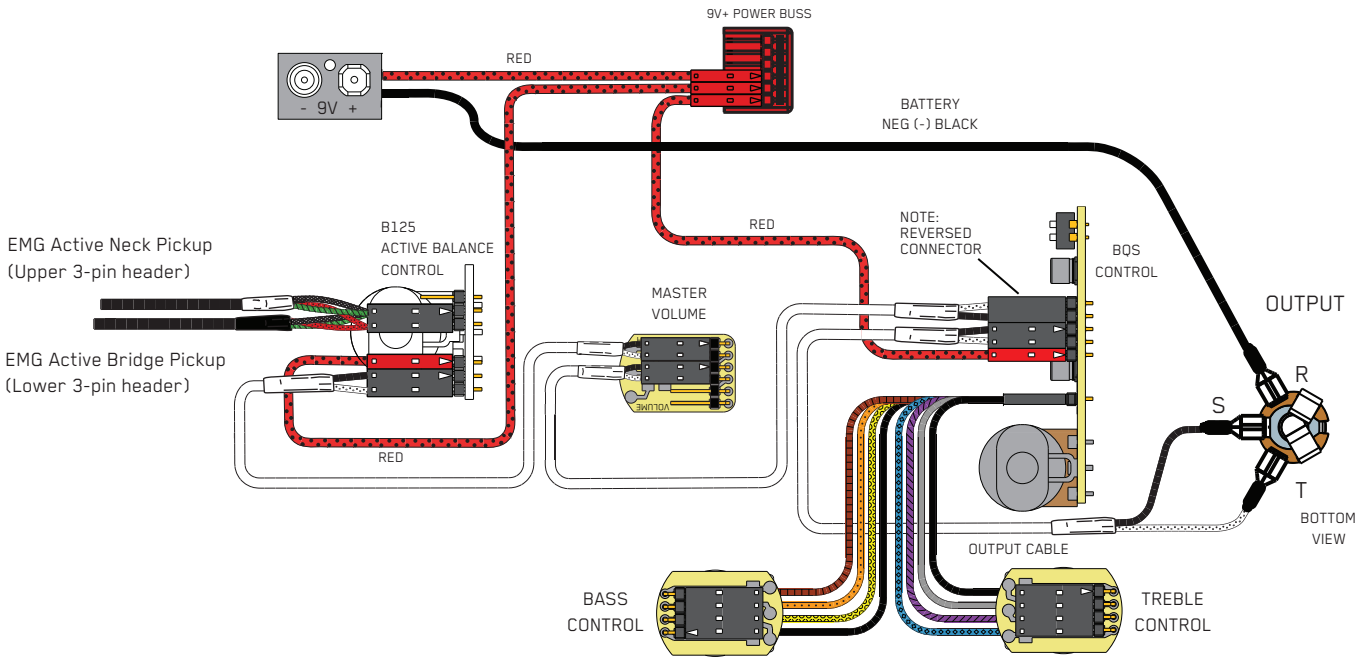

Diagram #5

If the instrument has a Battery Holder:

If your instrument has a 9 or 18 Volt battery holder you can still use the EMG Connectors to supply power to the pickups. Simply cut and strip the wires from the battery clip provided. Twist the wires together (Red to Red and Black to Black) and use the shrink tubing included to cover the connections. Soldering the wires is recommended.

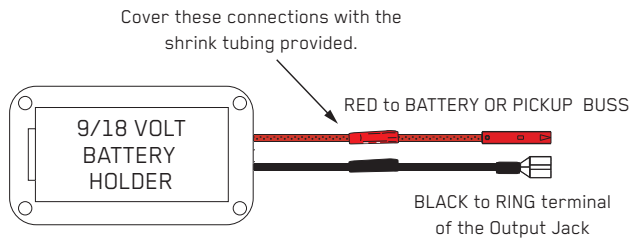

Diagram #6

+18 Volt Wiring Option:

If you want to operate your instrument at +18 Volts for more headroom then use 2 batteries wired as below. Also, if you are using any type of EQ in your instrument (EMG-BT, BQ) or anything that boosts the pickup signal then +18 Volts is recommended.

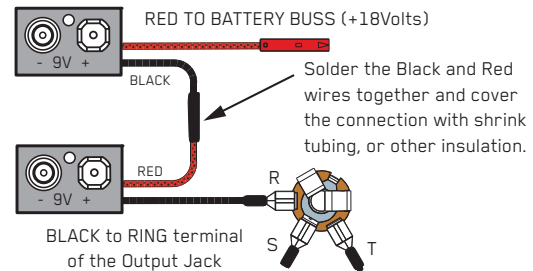

Diagram #7

Soldering to the 152B Panel Jack:

If your instrument has a long Panel Jack like the one below you will have to solder the output cable as shown. Ground (Black) to the Sleeve
Signal (White) to the Tip
Battery Negative (Black) to the Ring

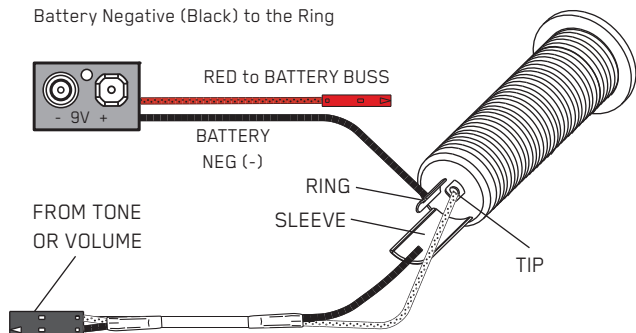

Diagram #8

Soldering to the battery buss:

If your instrument has an older EMG Pickup you can solder the pickup RED wire to the buss. Simply use some needle nose pliers, pull out the V+ header and solder the RED Wire from the pickup(s) to any of the pins and then re-insert the header into the housing.

