



## MINNOW

### Single Channel Bass Preamp

Congratulations on your purchase of the Trickfish Minnow. The Minnow is a high quality, low noise preamp and DI equipped with our Bullhead EQ section. This single channel Bullhead preamp features shelving EQ's for the BASS and TREBLE controls and variable band pass EQ's for the LOW MID and HIGH MID. A selectable mid frequency for both LOW MID and HIGH MID controls provide complete control over the midrange. We've also added HI SHIFT to the treble frequency to further tune the cut/boost capability of the treble control. In addition, the Minnow includes a tuner out for silent tuning and a balanced XLR output for use as a DI, great for both live and studio use.

### Using the Minnow

Start by plugging a 12VDC adapter into the jack on the top of the Minnow. Connect an instrument cable from your bass into the INPUT jack and an instrument cable from the OUTPUT jack to your amplifier, power amp, or powered speaker. Optionally, connect an XLR cable to the DI OUTPUT jack into a mixer or recording interface. Press the ON footswitch to engage the EQ of the Minnow. The blue LED will be on and you can begin adjusting the controls of the EQ.

\* The Minnow must be powered on to pass signal.



### Controls

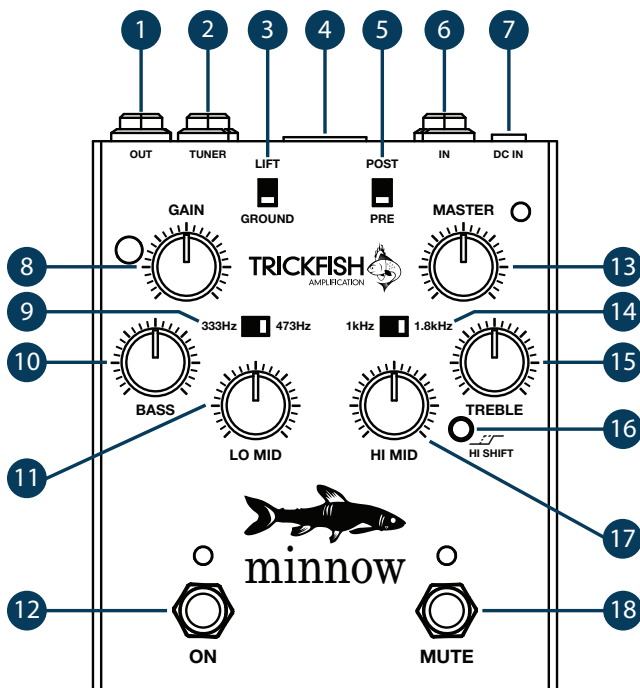

1. OUT: 1/4" phone jack routes the signal to the destination device
2. TUNER OUT: 1/4" phone jack sends signal to tuner. Stays active while in mute
3. GROUND / LIFT Switch: Ground lift dedicated to DIRECT OUT
4. DIRECT OUT XLR: Balanced XLR connection
5. DIRECT OUT PRE/POST select switch: Switches between a Pre-EQ or Post-EQ send
6. IN: Instrument Input 1/4" phone plug line input
7. DC IN: AC Mains Input with power on/off LED indicator. Attach cable firmly into socket. 12V 500mA Center Negative, Illuminated blue LED indicates power is on. No light means power is off
8. GAIN with level indicator: Input level adjust, green LED indicates signal and red LED indicates a clip
9. LO MID frequency select: Selects the frequency for the LO MID bandpass EQ
10. BASS shelving EQ cut/boost: Center is flat. Counter clockwise cuts, clockwise rotation boosts
11. LO MID cut/boost: Center is flat. Counter clockwise cuts, clockwise rotation boosts
12. ON footswitch: Engages EQ
13. MASTER: Controls the overall output volume
14. HI MID frequency select: Selects the frequency for the HI MID bandpass EQ
15. TREBLE shelving EQ cut/boost: Center is flat. Counter clockwise cuts, clockwise rotation boosts
16. HI SHIFT: Treble frequency shelving shift button, Out is low (4kHz), In is high (8kHz)
17. HI MID cut/boost: Center is flat. Counter clockwise cuts, clockwise rotation boosts
18. MUTE footswitch: Mutes all outputs except the TUNER OUT