

## DELANO **THEHYBRID** SERIES

An uncompromising pickup that combines in one single construction the two most legendary sounds in bass history

### **Part 1: J-Bass™**

Single coil bridge pickup with the immortal characteristics of early 60's pickups. AlNiCo 5 magnet coil body made of vulcanized fiber and gauge 42 wire.

### **Part 2: Sting Ray™ Humbucker**

Low resistance neck coil with 9.5 millimeter AlNiCo 5 magnets. Authentic sound guaranteed in this setting too, thanks to the special engineered bridge J-coil: the second MM™-coil is integrated inside.

### **Switching concept:**

The integrated switch manager lets you get both of these great classic sounds at the touch of a toggle, each one reconstructed exactly in its original form with all its strengths and nuances of character: Passive function in single-coil mode, active function with the DELANO SONAR 2- or 3-band EQ activated in Humbucker mode. The internal switching of the pickup is lightning fast, too!

For maximum sound authenticity we recommend the custom neck version of our J™-single coil JC4AL/H or JC5AL/H for the neck position. With both pickups switched on, this JJ-arrangement typically produces a noise-free output.

### **No trouble with treble:**

The 'TheHybrid' set includes a specially designed treble pot that works as a typical passive tone control for the J™-sounds in the passive mode and doubles as the active treble EQ in the Sting Ray™ setting. The neutral setting is located conveniently in the middle position; when switching, it's easy to get the basic settings you need.

### **Additional features:**

In the humbucking mode - we call it 'Ray' mode - you're able to combine TheHybrid pickup with the neck pickup, too. This is an additional feature. But take note, that use of the neck side single coil pickup typically causes hum, if driven with the active electronics. To achieve an authentic 'Ray' sound, you should turn the balance knob fully backwards - and so your bass is hum-free.

## „TheHybrid“ Series wiring

For 2 pickups & 2 volume pots

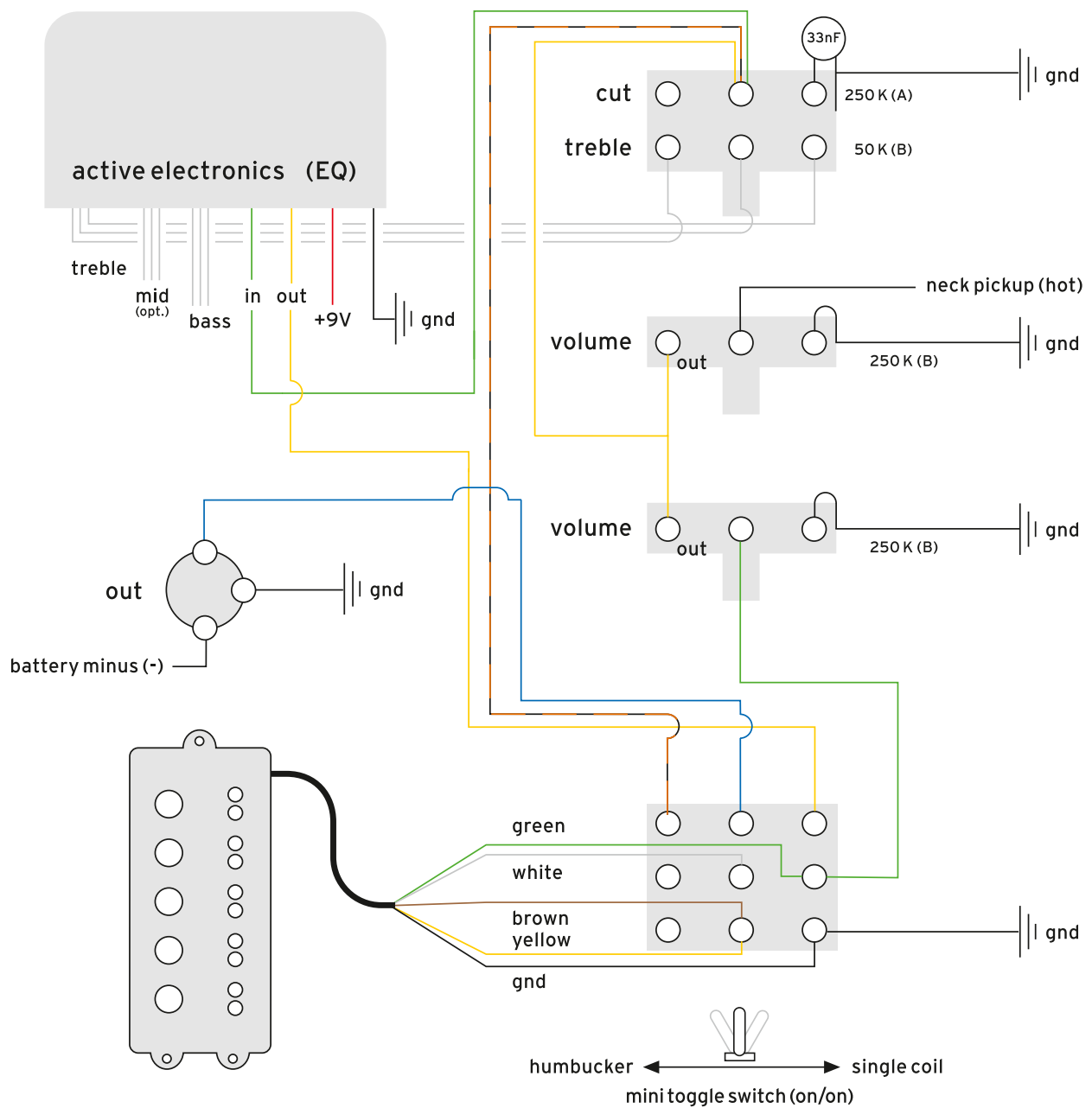

## „TheHybrid“ Series wiring

For 2 pickups, balance- & volume pot

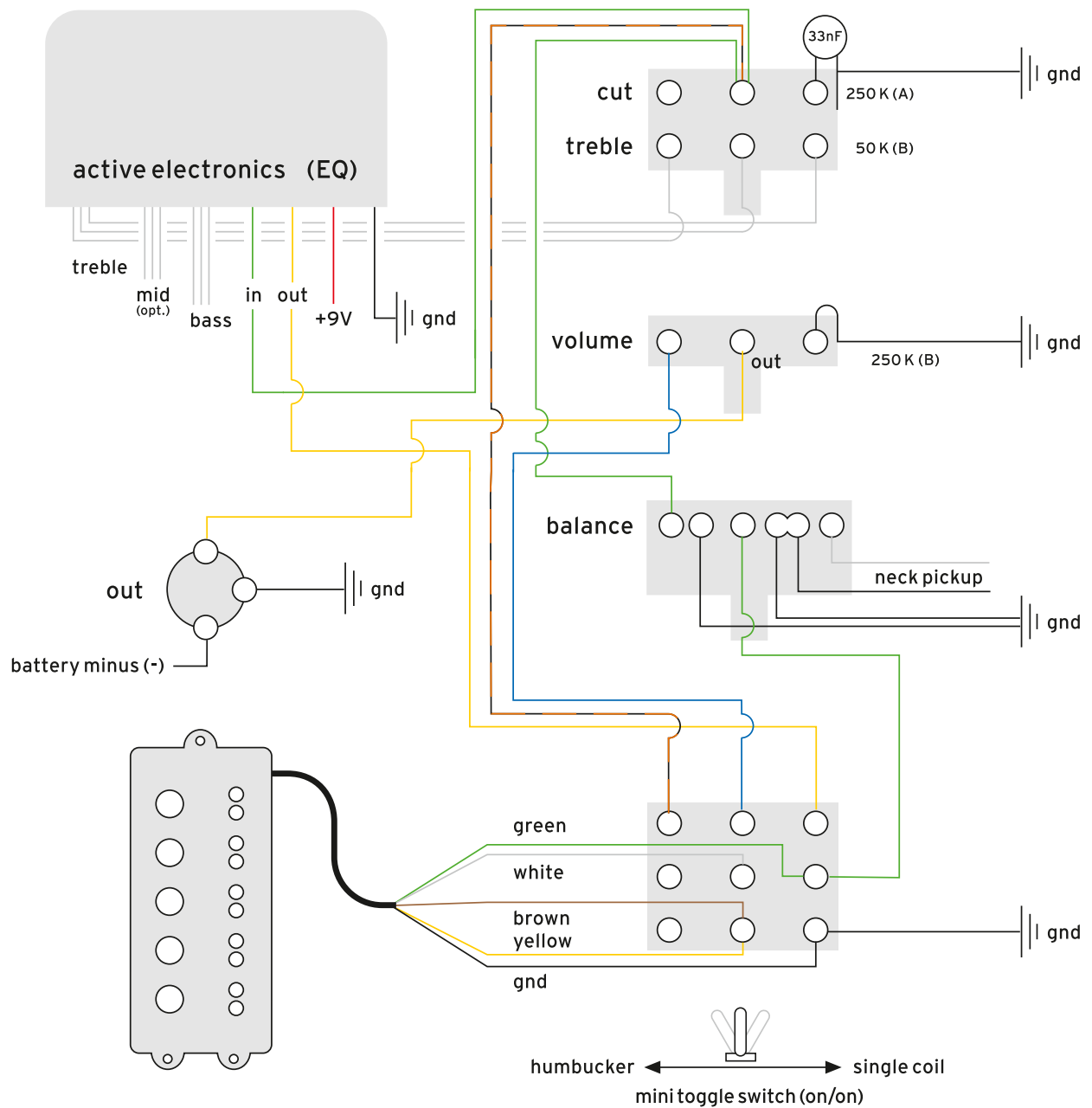

## „TheHybrid“ Series wiring

For 1 pickups & volume pot

