

APPLICATION:

PRODUCT NAME:
CTL VLV SDLH RIG SV

JOB NAME:

MODEL:

QUANTITY:

ITEM NO.:

12890 CTL VLV SDLH RIG SV

OPTIONS OR MODIFICATIONS:
 OTHER _____

FEATURES

- CONTROL VALVE**
- * STEM - LEFT HAND
 - * HOT AND COLD INDEX BUTTONS
 - * SWIVELLING SEAT DISK
 - * STAINLESS STEEL SEAT
 - * STAINLESS STEEL SEAT SCREW
 - * STAINLESS STEEL HANDLE SCREW

- SYSTEM LIMITS**
- * TEMP: 40°F MIN. TO 160°F MAX.
 - * PRESSURE: 200 PSI MAX. STATIC

- SHIPPING WEIGHT**
- * 2.75 LBS

- PRODUCT COMPLIANCE:**
- * ASME A112.18.1 / CSA B125.1
 - * NSF 61 - Section 9
 - * NSF 372 (Low Lead Content)

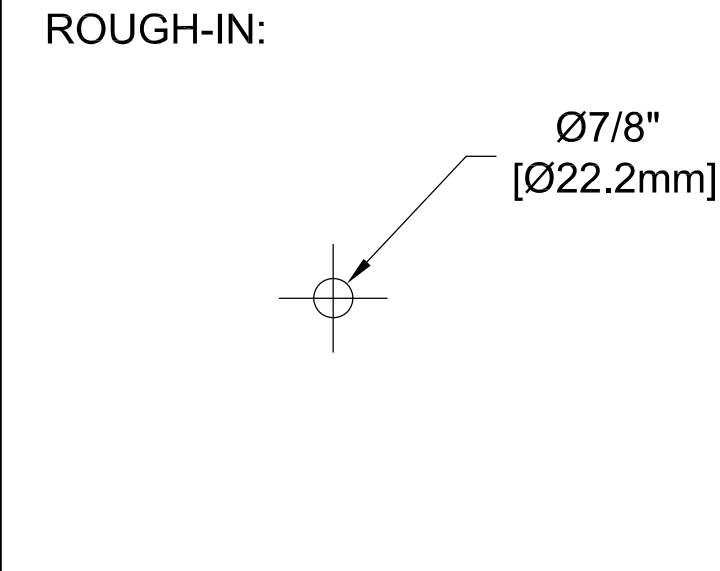
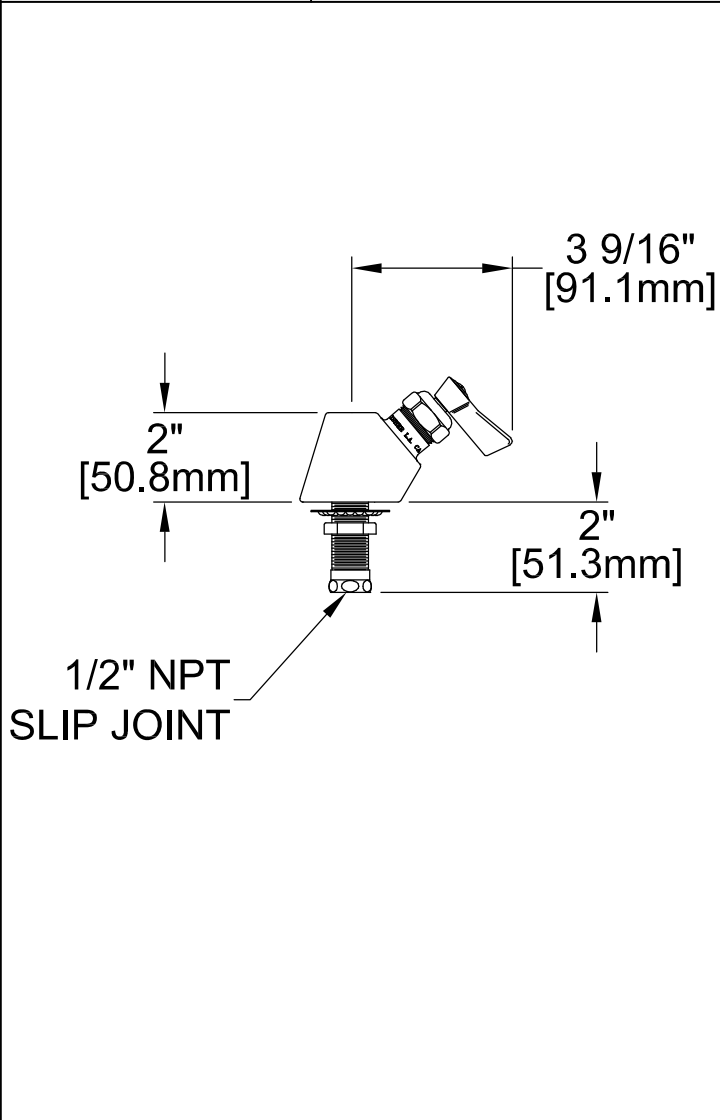

FISHER MANUFACTURING COMPANY
 TOLL FREE: 800-421-6162 - FAX: 800-832-8238
 information@fisher-mfg.com - www.fisher-mfg.com