

SNAP-N'-GLIDE CORDLESS ROLLER SHADE

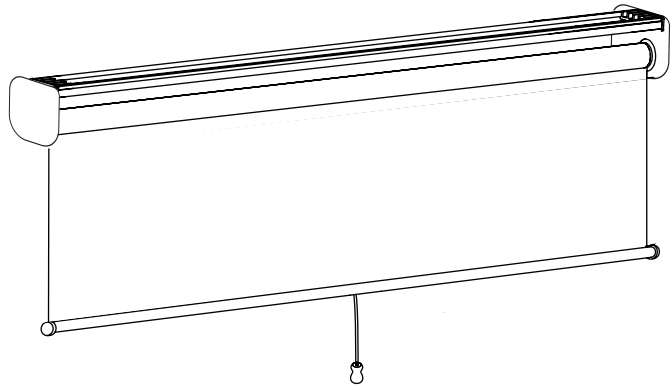

PREPARATION

1 Check the Hardware

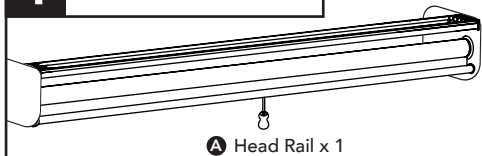

A Head Rail x 1



B Mounting Bracket
23" - 39" = 2
48 x 72 = 3



C Screw
23" - 39" = 4
48 x 72 = 6



D Anchor
23" - 39" = 4
48 x 72 = 6

2 Gather other necessary tools

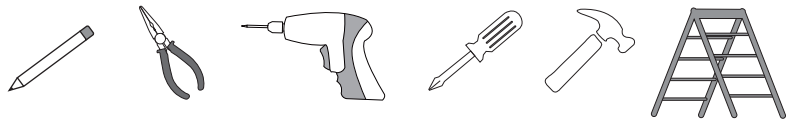

INSTALLATION

1 Measuring

Mark where the **Mounting Brackets B** should be installed.

2 Mounting Brackets should be positioned 4 inches from the left and right edges of the blinds. Use a steel tape measure and a level to ensure accuracy.

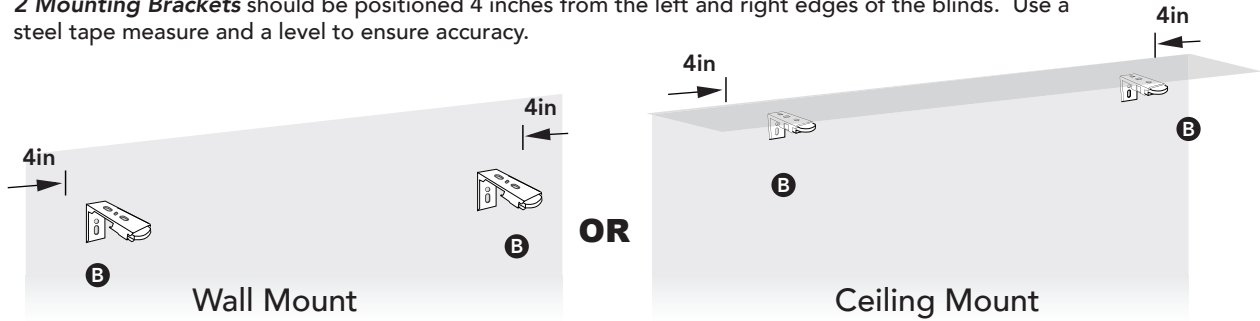

2 Install Ceiling Mounts Brackets to ceiling

Drill 2 screws **C** for each **Mounting brackets B** to the wall or ceiling.

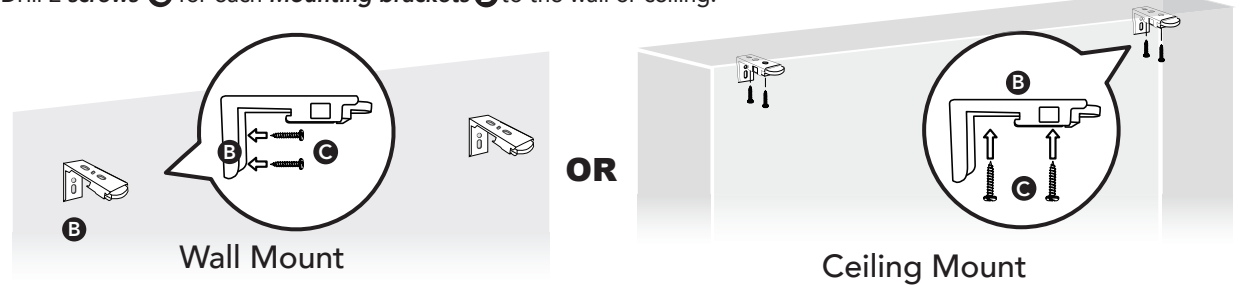

3 Mount Headrails to the ceiling

Insert the shades under the inner back edge of the bracket. **Push the tab on the front of each bracket** and rotate the headrail upward until it's completely inserted then release the tab. **To remove the shade**, push the tab again to release the shade while supporting the shade's weight to avoid the shade falling to the floors.

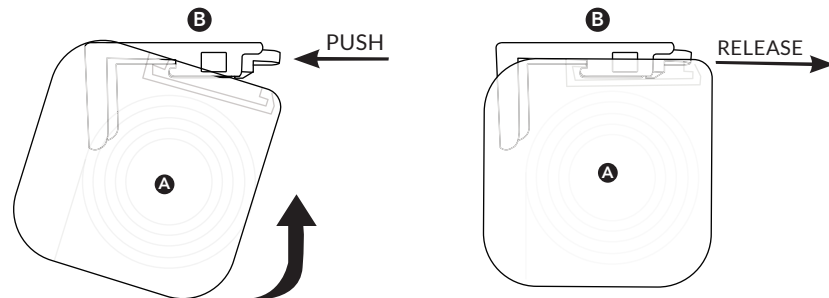



Quick How-to-use Guide

To open and close blind: Pull and tuck.

