









CORDLESS ROMAN SHADE

PACIFIC COLLECTION

Check Components

Roman Shade Components	Shade Width Up to 39 in	Shade Width 47 in and up
Mounting Bracket 	x 2	x 3
Screws 	x 4	x 6
Anchors 	x 4	x 6

Prepare necessary tools

Screw driver 	Measuring Tape 
Pencil 	Drill / Drill Bits 
Hammer 	Ladder 

STEP 1: DETERMINE INSIDE/CEILING, FLUSH, WALL OR OUTSIDE MOUNT

a. Inside/Ceiling or Flush Mount

(A minimum 1 inch depth is required or 2 inches depth for flush mounts.)

- 1) Position brackets approximately 2 inches from the ends of the headrail.
- 2) Mark the bracket locations upward through the holes with a pencil.
- 3) Use the screws and anchors in the top bracket holes to attach your brackets.

Step 1

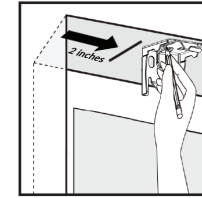

Step 2

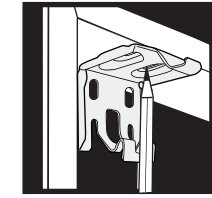

Step 3

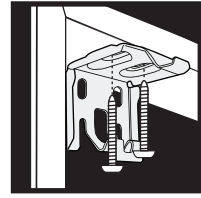

b. Wall or Outside Mount

(A minimum 1/2 inch flat wall space is necessary)

- 1) Position brackets approximately 2 inches from the ends of the headrail. If your shade had a third bracket provided, position middle brackets to align with pre-drilled holes in the headrail.
- 2) Mark the bracket locations through the rear holes with a pencil.
- 3) Use the screws and anchors in the rear bracket holes to attach your brackets.

Step 1

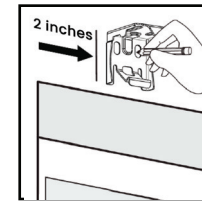

Step 2

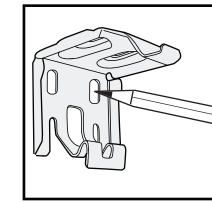

Step 3

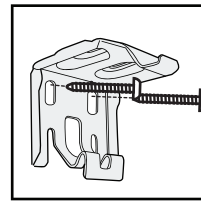

STEP 2: ATTACHING SUPPORT RODS

Swing the support rods into the square brackets that are attached to the back of the shade. Snap on place by pressing firmly and click support rods together.

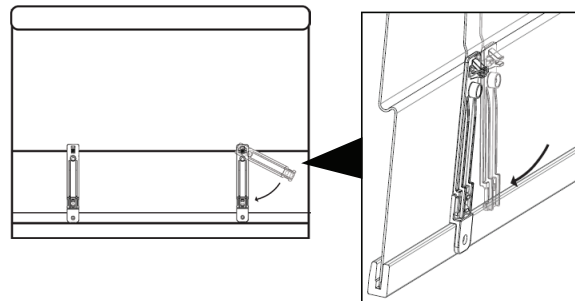

STEP 3: MOUNTING THE SHADE

- 1) Attach front lip of the headrail into the front lip of each mounting bracket.
- 2) Rotate and push headrail back into the spring tab until it clicks into place.

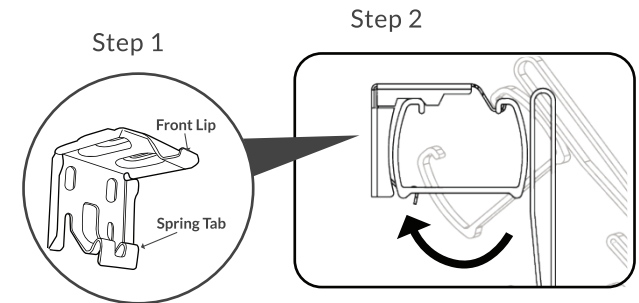

STEP 5: HOW TO OPERATE

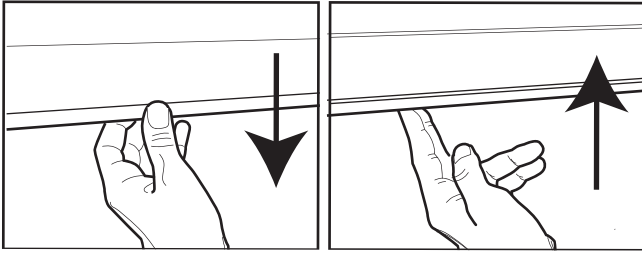

To lower your blinds, simply pull to the desired position and release.

To raise your blinds, push up to desired position and release.

CLEANING & CARE

Periodic cleaning is suggested. For best results, use a vacuum cleaner. For spot-removal use a mild fabric cleanser, suitable for polyester and follow the manufacturers directions.

Chicology Ready-Made Blinds Warranty Limited One Year Warranty from the Date of Purchase

What is Covered:

All of our shades are warranted against manufacturer defects in materials or workmanship provided that you are the original purchaser of the product, and the product was installed according to our instructions.

What is Not Covered:

- Normal wear and tear.
- Consumer damages caused by accidents, alternations, abuse of the product, exposure to salt air, misuse, or damages from pets or insects.
- Damages resulting from removal and reinstallation in the same or any other window or application, or failure to follow instructions, such as measurement, installation, cleaning, and maintenance.
- Any products that, with the passage of time, has yellowing or cracking of plastic parts.
- Wrong measurements are not covered by the warranty and are not refundable.

To Report Shipping Damages:

If damage occurred during shipping, please email and call us immediately and report within **14 calendar days** or else you may be denied for your damaged product.

To Obligations to the consumer:

The obligations of Chicology are limited to the repair or replacements of parts or products found to be defective. Chicology will determine if the product is defective or not and may replace the product. If the product is found to have manufacture defects, we will repair or replace the product. Colors do vary from lot to lot, and may not match original product exactly. Discontinued items will be replaced with the most current product of the same price.

Your Rights under State law:

This limited warranty gives you specific legal rights, and you may have other rights, which vary from state to state.

Defective Product:

If you believe your shade has a manufacturing defect, please email and call us.



Need Further Assistance?



We stand by our products and we're here to help. Call or email us, and expect a reply within 1 business day.

Visit our website for how-to videos and FAQs.

Website : www.chicology.com/help
Email: support@chicology.com
Phone: **1 (866) 999-6188**
Hours: **Mon-Fri 8AM to 5PM (PST)**



 Chicology Home
 Chicology Home

 Chicology Home
 Chicology Home