

# ScaleRID

## SR-1000/SR-2000

Hard Water Treatment System

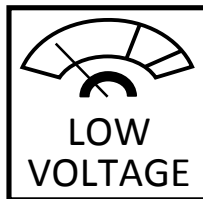
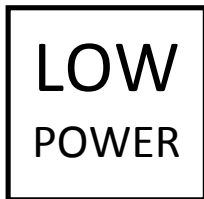

Instruction Manual

# Table of Contents

<b>I. Overview</b>	<b>3</b>
<b>II. Contents</b>	<b>4</b>
ScaleRID SR-1000	4
ScaleRID SR-2000	5
<b>III. Installing the ScaleRID System</b>	<b>6</b>
<b>IV. Control Module Setup</b>	<b>13</b>
<b>V. Troubleshooting Guide</b>	<b>15</b>
<b>VI. Technical Specifications</b>	<b>16</b>
<b>VII. Maintenance and Cleaning</b>	<b>17</b>
<b>VIII. Frequently Asked Questions (FAQ)</b>	<b>18</b>
<b>General Safety Information</b>	<b>21</b>
<b>Warranty</b>	<b>22</b>
<b>FCC Part 15 Regulation</b>	<b>23</b>

## I. Overview

Congratulations and thank you for choosing a ScaleRID Hard Water Treatment System.

The ScaleRID SR-1000 and ScaleRID SR-2000 Hard Water Treatment Systems are environmentally friendly, electronic water treatment systems. ScaleRID systems treat water by increasing the nominal precipitation rate of certain minerals in the water, which, as a result, alters the materialization of mineral build-up in the form of scale on the surfaces of pipes, fixtures and appliances connected to your home's water system.

Please read this instruction manual carefully for quick, easy and successful installation of your ScaleRID system.

## II. Contents

### ScaleRID SR-1000

The ScaleRID SR-1000 box contains the following:

Item	Description
1	ScaleRID SR-1000 Control Module
2	UL/FCC approved AC/DC switching Power Supply Cord
3	Quick Connect Coil with two leads approximately 10 feet long
4	Three QCC Size Foam Adapters
5	Four Screws with wall anchors
6	Two Hooks
7	Instruction Manual



## ScaleRID SR-2000

The ScaleRID SR-2000 box contains the following:

Item	Description
1	ScaleRID SR-2000 Control Module
2	UL/FCC approved AC/DC switching Power Supply Cord
3	Two Quick Connect Coils with two leads approximately 10 feet long
4	Six QCC Size Foam Adapters
5	Four Screws with wall anchors
6	Two Hooks
7	Instruction Manual

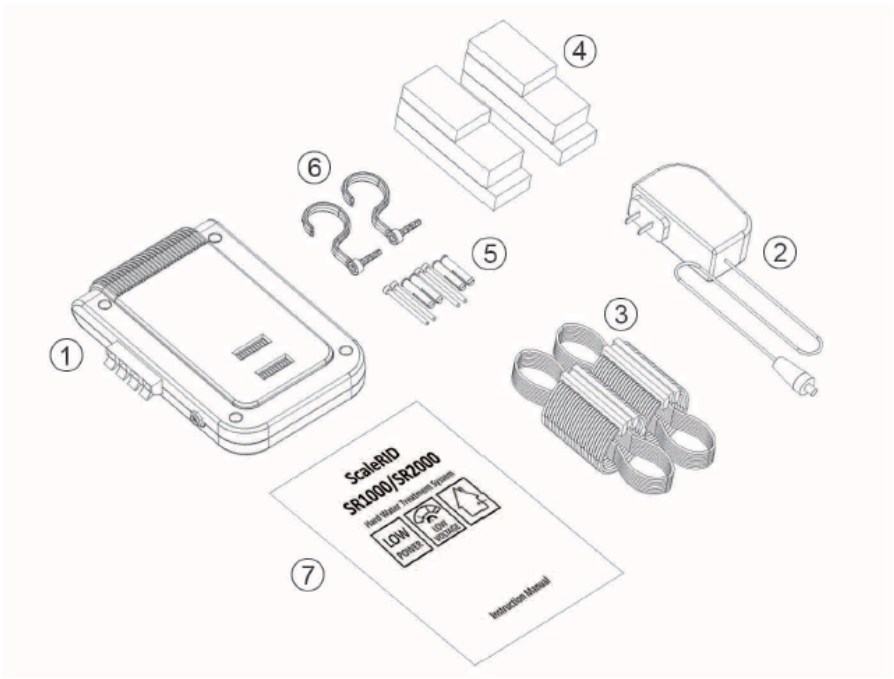

### III. Installing the ScaleRID System

The following best practices guidelines should be considered when selecting the proper installation location for the ScaleRID system:

The ScaleRID system is designed for indoor installation.

---

It is best to place the ScaleRID Quick Connect Coil closest to your home's incoming water source, *before* any appliances, water heaters, or other treatment devices.

---

If a water meter is installed on the inside of your home, install the coil after this meter.

---

The Quick Connect Coil(s) can be placed on a water pipe regardless of orientation. For example, the water pipe can be vertical, horizontal or even diagonal.

---

For best performance, the Quick Connect Coil(s) should be installed at least six inches away from any metallic object, appliance or other electrical devices.

---

Each Quick Connect Coil is supplied with two wires. These wires are the maximum recommended length the coil should be from the ScaleRID control module. The wires can be shortened, but it is not recommended that any additional length be spliced or added on to these wires.

---

#### **Step 1: Locating where to install the Quick Connect Coil(s)**

- Locate the incoming water supply. Find a straight length of pipe at least four inches long that meets the preceding “best practices” guidelines. This pipe can be vertical, horizontal or even diagonal.
  - Loosely wrap the Quick Connect Coil around the pipe at this location. > **Do NOT snap the Quick Connect Coil together at this time.** <
  - Please note for the ScaleRID SR-2000 model, which has two (2) Quick Connect Coils, it is important they are placed at least 10 inches, but not more than 40 inches, apart.
- > **Do NOT snap the Quick Connect Coil together at this time** <

## Step 2: Locating where to mount the ScaleRID Control Module

There are two options to mount the ScaleRID Control Module (see *Fig. 1* & *Fig. 2*).

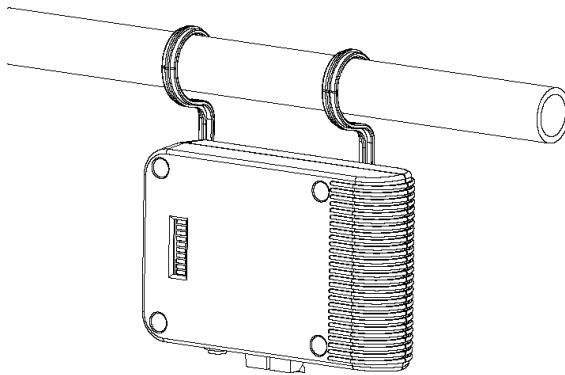

***Fig.1 - Hanging from a Pipe***

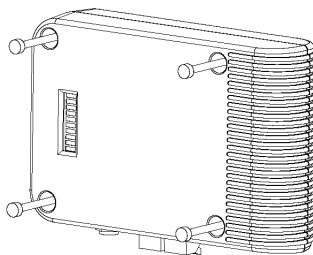

***Fig.2 - Wall Mounting***



## Option 1: Hanging from a pipe with Easy-Install Hanging Straps

No tools required

- Locate a section of water pipe, preferably horizontal, between the Quick Connect Coil location determined in Step 1 on page 7, and an electrical outlet.
- Check for adequate wire length from the Quick Connect Coil to the Control Module.
- Be sure the Power Supply Cord will reach from a nearby electrical outlet to the Control Module. Consult with a licensed electrician if an electrical outlet is not within range.
- Follow *Fig. 3* below to install the Easy-Install Hooks.
- i) Insert one hook at a time into the slotted holes from the back of the Control Module.
- ii) Rotate each hook until it is vertical.
- iii) Feel the hook 'snap' into this vertical position.

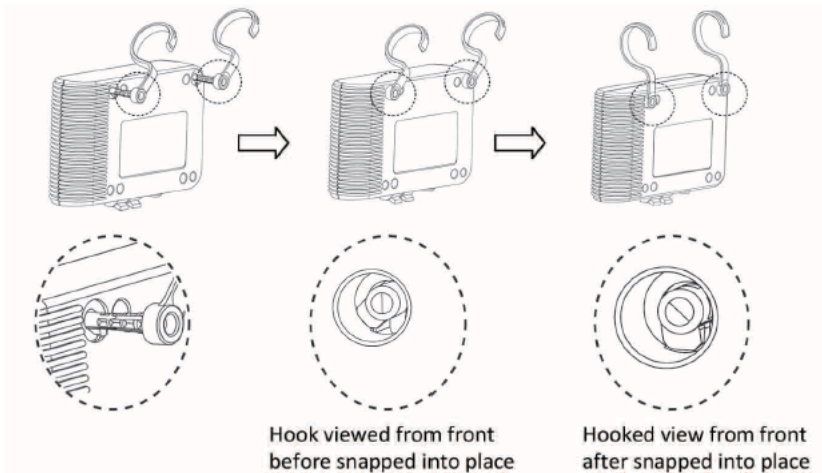

***Fig.3 - Installing the Easy -Install Hooks to the Control Module***

- Hang the Control Module from the pipe. Note the plastic hooks will flex around a pipe up to one inch in diameter.

## Option 2: Wall Mounting

Required tools: Drill and screwdriver

- Locate sufficient open space on a wall between the Quick Connect Coil location that you determined in Step 1 on page 7 and an electrical outlet. Remember, the ScaleRID SR-2000 has 2 Quick Connect Coils to connect. The Control Module can be mounted horizontally or vertically.
- Check for adequate wire length from the Quick Connect Coil to the Control Module.
- Be sure the Power Supply Cord will reach from a nearby electrical outlet to the Control Module. Consult with a licensed electrician if an electrical outlet is not within range.
- Use the Control Module as a template to mark the center of the four holes on the wall using a pencil, pen or a screw supplied in this package (simply press the screw into the wall leaving a small indent or mark).
- Pre-drill the wall in all four places using a 7/32" inch drill bit.
- Press the anchors into the newly drilled holes in the wall.
- Hold the ScaleRID Control Module in place and insert the supplied screws through the holes in the module, per *Fig. 4* below.

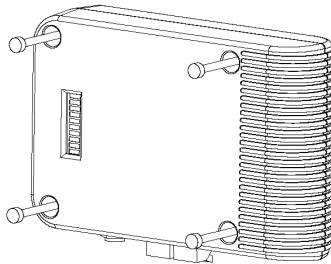
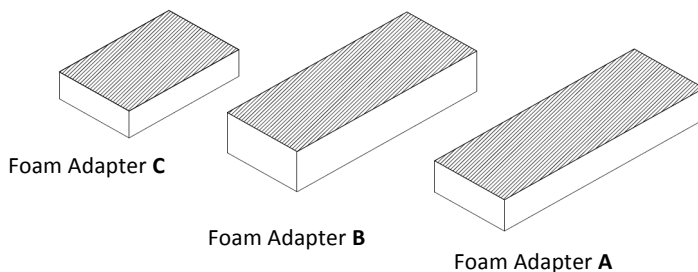

***Fig. 4 - Mounting the Control Module to the wall***

- Lightly tighten the screws, being careful not to over tighten as this may crack the plastic housing of the Control Module.

### Step 3: Mount the Quick Connect Coil (QCC)

- The Foam Adapters supplied in this package are designed to adapt the Quick Connect Coil to any standard water pipe size of approximately  $\frac{1}{2}$ " ,  $\frac{3}{4}$ " or 1" diameter.



**Fig.5 - Foam Adapters for QCC**

- To determine your water pipe diameter and the amount of Foam Adapters to be used during installation, measure the circumference of the pipe by wrapping a flexible measuring tape around the pipe. Using the chart below, convert the circumference to diameter, then select the proper amount of Foam Adapter(s).

Pipe Circumference	Pipe Diameter	Foam Adapter
3.1" to 3.3"	1"	NONE
2.2" to 2.4"	$\frac{3}{4}$ "	1
1.5" to 1.7"	$\frac{1}{2}$ "	2

- Peel the liner off the double-sided tape and adhere the Foam Adapter to the pipe where the coil will be mounted. The Foam Adapter should adhere to one side of the pipe (see Fig. 6).

- **Note:** For installation on ½” diameter pipe, adhere one Foam Adapter to one side of the pipe then adhere the second Foam Adapter on the other side of the pipe to provide the proper thickness for installation of the Quick Connect Coil.
- Wrap the Quick Connect Coil around the Foam Adapter twice and snap together (see Fig. 6).

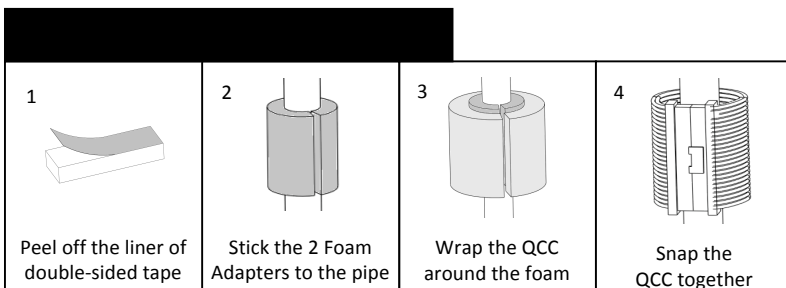
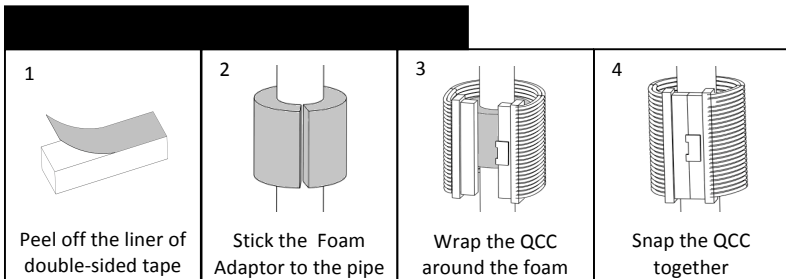
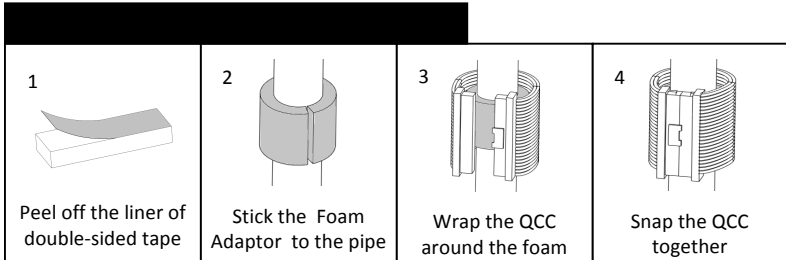

**Fig. 6 – Applying the QCC & Foam Adapter For Various Pipe Diameter**

## IV. Control Module Setup

- Insert each end of the wire from the Quick Connect Coil to either of the spring clip receptacles (see Fig. 7) located on the Control Module. Note that polarity is not important.
- If you need to remove the wire, depress white button above wire with the tip of a screw driver or a pen.
- For the ScaleRID SR-2000 model, be certain to connect each Quick Connect Coil to its own spring clip pair.
- Attach the 12 Volt Power Supply Cord to the Control Module (see Fig. 7).
- Connect the Power Supply Cord to the electrical outlet (110V or 220V AC power supply).

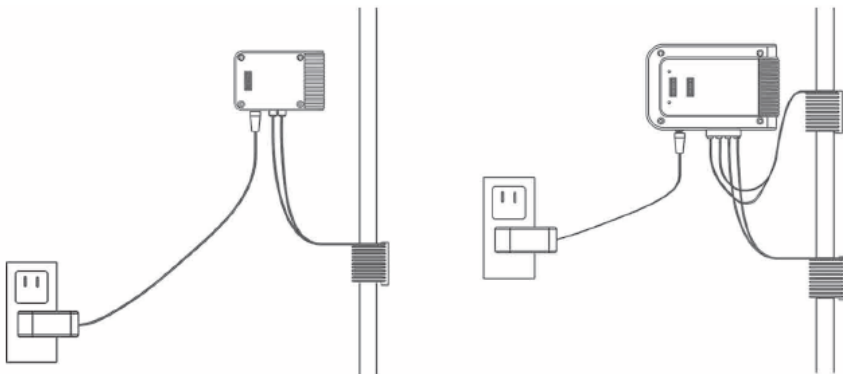
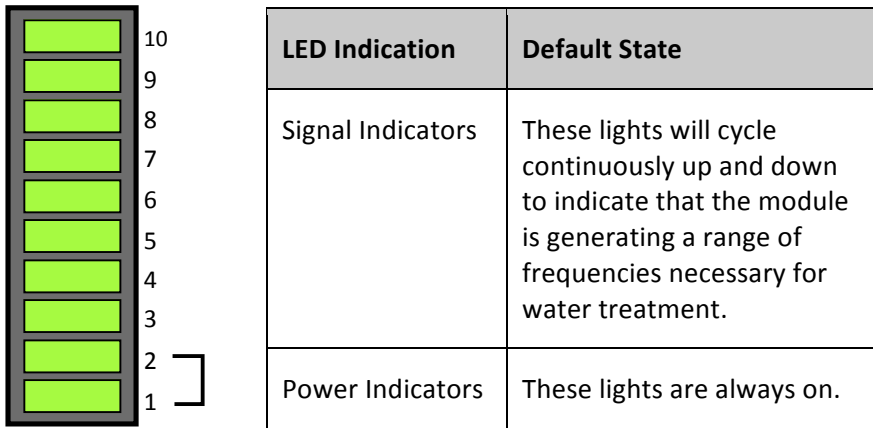

**Fig. 7 - Connect the QCC and Power Supply to the Control Module**



**FIRE HAZARD** – to avoid overheating, ignition, possible fire and serious injuries, use only the power adaptor that is supplied with the device. You may use an extension cord if the Power Supply Cord is not long enough. Do not use any other adapter you may have in your home.

- Once powered, the LED bar graph will start pulsating, indicating successful Quick Coil Connection and proper operation of the Control Module. See Fig. 8 for further details.



**Fig. 8 - LED Bar Graph Indication**

Installation is now complete. Every couple of months you may want to check to see that the lights are still cycling up and down, which is the extent of your maintenance. No more salt, no more noisy regeneration, no more wasted water and soon... no more limescale. Welcome to the 21<sup>st</sup> century way to electronically treat hard water.

## V. Troubleshooting Guide ~~2000~~

Problem	Possible Remedies
The unit does not respond (LED bars fail to illuminate).	<ul style="list-style-type: none"><li>• Make sure the unit is plugged in and the power is turned on.</li><li>• Check the power outlet to make sure it is operational and not controlled by a separate switch.</li></ul>
All LED bars are flashing simultaneously.	<ul style="list-style-type: none"><li>• Indicates that the Quick Connect Coil is not connected to the Control Module. To resume normal operation, make sure each end of the wires from the coil(s) is (are) connected to either one of the spring connector receptacles on the Control Module, one wire per receptacle.</li></ul>
The two lower LED bars flash, but the rest of the LED bars do not illuminate.	<ul style="list-style-type: none"><li>• Unplug the unit. Wait 10 seconds and plug in again.</li></ul>
All the LED bars are illuminated solid (no flashing).	<ul style="list-style-type: none"><li>• Unplug the unit. Wait 10 seconds and plug in again.</li></ul>

## VI. Technical Specifications

Physical Properties	ScaleRID 1000	ScaleRID 2000
Supply Voltage	110-240VAC, 50/60Hz	
Input Operation Power	DC12V @ 1.5A	
Power Consumption	Average 6 Watts	Average 12 Watts
Operating Temperature	-4°F(-20°C) to 149°F (65°C)	
Max. component temperature	176°F	185°F
Max. enclosure temperature	140°F	160°F
Capable of driving	2 coils double stacked	4 coils double stacked
Output Indicators	LED Bar Graph for "Power On," "Operation," "Coil Connection Status"	
Enclosure material	ABS Plastic	
Dimension unpacked (LxWxH)	6.06"x3.5"x1.4"	7.7"x5.0"x1.0"
Weight packed	Maximum 1.5 lbs	Maximum 2.0 lbs
Electrical Standard Certification	FCC Part 15 Class B	



## **VII. Maintenance and Cleaning**

1. This device is intended for indoor use only. Do not expose the device to outdoor or extreme weather conditions.
2. Install the device in a dry place.
3. The device is durable and does not need excessive cleaning. If cleaning is desired, unplug the device before dusting.
4. Do not immerse the Control Module in water, simply brush away any dust and wipe with a damp cloth if required.
5. Avoid contacting the spring clip terminals with the damp cloth.
6. Do not use abrasive cleaners or steel wool.

## VIII. Frequently Asked Questions (FAQ)

### *How do I know the ScaleRID system is working?*

The amount of time required before you experience the effects of the system varies depending on the amount of water used. Generally, signs of descaling are seen within two weeks.

Note: Initially you may notice that the device appears to be less than fully effective. This is due to the removal of the pre-existing scale, which causes increased water hardness until the existing scale is removed. You will observe the full effectiveness of the system once the pre-existing scale has been removed from the pipes.

### *How can I monitor the descaling process?*

You can easily monitor the descaling process by observing external indicators. After typical use of 30 to 90 days, showerheads and faucets will become scale free and the aerator screens will show no scale. With this you can safely assume that the ScaleRID system's descaling process is working and is preventing scale build-up inside the entire water system being treated.

### **External Scale**

You may use an external area of scale build-up as a reference to determine that the system is working. Areas to observe:

1. As long as the newly treated water is in regular contact with the desired area, such as faucets, sinks, etc., the scale around these areas will begin to soften and the deposits will disappear on their own, or they can be easily removed by cleaning.
2. Surfaces in contact with the treated water become easier to clean.
3. Scale on showerheads softens and disappears, and periodic showerhead cleaning or replacement becomes unnecessary.

## Internal Scale

1. As the heating element inside your hot water system is descaling, water heating will become progressively more efficient. Water will then heat faster saving up to 30% in energy use. You may save additional energy by reducing the water heater's thermostat setting while still having sufficient hot water.
2. If the water system was severely scaled, you may also notice an improvement in water flow.

If you want to see actual chemical proof of the device working, follow this procedure. Immediately after installing the ScaleRID system, measure the hardness at the incoming water supply (before the ScaleRID system) and the treated water from a tap that is used frequently. Then measure both points every two weeks. The hardness of the ScaleRID treated water will typically be 10% to 20% higher than the hardness of the incoming water until the descaling process is complete. Once the descaling process has run its course, there will be no measurable difference in water hardness between the two points. Keep in mind, with a ScaleRID system the minerals are not removed from the water; the water is modified, allowing the minerals to simply pass through the system instead of collecting and forming scale.

### ***What does the ScaleRID system do that a water softener does not?***

1. It saves energy costs by preventing scale build-up in water heaters and appliances.
2. It saves money by eliminating the need for a softener and repeated purchases of salt.
3. It provides salt-free water, which is a concern for many health-conscious people.
4. As a result of the periodic regeneration cycle, conventional water softeners discharge salt-laden water into the water table, but

ScaleRid systems do not require any purging or regeneration, keeping the environment clean and safe.

5. It reduces the consumption of detergent.
6. It actually prevents limescale from developing and, over time, can dissolve existing limescale.

***What does a water softener do that a ScaleRID system does not?***

1. The water softener softens hard water by replacing the calcium and magnesium with sodium.
2. A water softener adds salt in your water and drains damaging chlorides into the environment.
3. Water softeners require that you purchase salt on a regular basis.
4. A softener gives you the slimy feeling that you cannot rinse all of the soap from your body.
5. Water softeners make your skin dry.
6. Softeners require you waste water for regeneration.

***Will I see any difference in soap scum and the effects on my skin?***

You will usually notice changes as follows:

1. A reduction of about 20% in soaps/detergents needed.
2. Less scum forms on the bathtub or in the shower and there is improved soap lather.
3. An improvement in skin condition for anyone suffering from dry or itchy skin.

## General Safety Information

FOLLOW ALL INSTRUCTIONS AND SAFETY WARNINGS IDENTIFIED IN THIS MANUAL AND ON THE EQUIPMENT TO AVOID POTENTIAL INJURY.

If you encounter any problems with the device, please read the Trouble-Shooting Guide first, and if the problem persists, please contact the authorized seller.

- **WARNING!** To prevent the risk of electric shock, do not attempt to open the device. There are no consumer serviceable parts inside the device. Opening the device or tampering with it in any way will void the warranty.
- This product is for indoor use only. Do not expose the device to temperature or humidity extremes, direct sunlight or sources of powerful light, excessive dust or vibrations.
- Mount the device on a stable, level surface. Do not drop, apply extreme force to the LEDs bar graph or put heavy objects on top of the Control Module.
- **WARNING!** Do not immerse in water.
- **WARNING!** Only use the power supply that is provided with the device.
- If cleaning of the outer casing is required, use a damp cloth without any cleaning fluids.
- **WARNING!** Shock Hazard. To avoid injury, always disconnect power cord from wall outlet before cleaning the device.
- Do not insert any implements or tools into the inner parts.

## Warranty

The ScaleRID Water Treatment System is guaranteed against manufacturing defects in material and/or workmanship under normal usage.

If the device needs any servicing, bring or send the device to your authorized ScaleRID dealer.

The period and conditions of the warranty are as follows:

- 1) Three-year warranty period from the date of purchase.
- 2) Parts not under warranty – Control Module housing.

The warranty is limited only to the repair or replacement of the defective parts, entirety at our discretion. There is no obligation under the terms and conditions of the warranty to replace or refurbish the complete unit.

This warranty is void under the following circumstances:

1. The device has been subjected to misuse or negligence, or used contrary to the manufacturer's instruction; or has been tampered with or altered in any way by unauthorized service personnel.
2. If the defect is caused by fire, lightning, acts of nature, pollution, abnormal voltage surge, the use of a generator, household pests or causes beyond the manufacturer's control.

## FCC Part 15 Regulation

### Class B device (Home/Office)

This equipment has been tested and found to comply with the limits for a Class B digital device, pursuant to part 15 of the FCC Rules. These limits are designed to provide reasonable protection against harmful interference in a residential installation. This equipment generates, uses and can radiate radio frequency energy and, if not installed and used in accordance with the instructions, may cause harmful interference to radio communications. However, there is no guarantee that interference will not occur in a particular installation. If this equipment does cause interference to radio or television reception, which can be determined by turning the equipment off and on, the user is encouraged to try to correct the interference by one or more of the following measures:

- Reorient or relocate the receiving antenna.
- Increase the separation between the equipment and receiver.
- Connect the equipment into an outlet on a circuit different from that to which the receiver is connected.
- Consult the dealer or an experienced radio/TV technician for help.

*CAUTION: Changes or modifications not expressly approved by the manufacturer responsible for compliance could void the user's authority to operate the equipment.*

