

AIR PURIFIER & STERILIZER OWNERS MANUAL



INCLUDES:
INSTALLATION
SPECIFICATION
FEATURES
OPERATION
MAINTENANCE
TROUBLESHOOTING

PurATron BEST AIR

IMPORTANT: SAVE THIS BOOKLET!

CONTENTS

Introduction	2
Specifications	2
Your New Best Air by PurATron	3
Inspection & Installation	3
Unit Features.	3
General Operation	4
LCD Display.	5
Maintenance Reminders	5
General Maintenance.	5
Removing the Rear Lint Screen.	7
Removing the Purifier Plate & PCO Cell	7
Installing the PCO Cell & Purifier Plate	8
Installing the Rear Lint Screen.	8
Troubleshooting	9
Warranty Information	10



WARNING! - Do not operate this unit without the rear lint screen AND back cover installed.



CAUTION! - The Away Mode feature of this unit is to be operated in unoccupied areas only.



CAUTION! - Disconnect power cord before servicing.



CAUTION! - Do not operate unit near heat sources, open flame, or combustible vapors or gases.

110 volt - use 1.6 Amp slow blow fuse.

INTRODUCTION

Congratulations! You have purchased one of the most effective, technologically advanced air purifiers available. Your new Best Air by PurATron is designed to provide years of trouble-free, low maintenance operation. Be sure to read and follow all service procedures outlined in this owner's manual, and use only PurATron replacement parts available from your PurATron business Owner.

If you have any questions concerning this, or any PurATron product, contact your place of purchase.

SPECIFICATIONS

Electrical:

- 110 volt 60 Hz
- 60 watts power consumption
- 24 to 30 KV, 20-30 Khz ion generation plusator
- Fixed 6.5 KV DC needle ion generator.

Size:

- Dimensions:
12" high x 9" wide x 11" deep
- Weight: 11 pounds

PCO cell output (normal mode)

- <0.02 ppm ozone (ambient room concentration)

Purification Plate Output (High Mode)

- 0-360 mg of ozone per hour

Coverage

- Covers a range of up to 3000 ft²**

**Depends on variables such as severity and frequency of pollution, humidity, and temperature.

Warranty:

- 3 years.
- See warranty card for specific details.

YOUR NEW BEST AIR BY PURATRON

- Virtually eliminates smoke, odors, and tobacco smoke.
- Includes HEPA filter which can remove very tiny dust from the flowing air.
- Germicidal, broad spectrum, high-intensity UVX lamp (100 - 300nm) working together with exclusive Photo-Catalyst-Oxidation cell to kill bacteria.
- Can remove odors from your home, office, car, boat, RV, etc.
- Improves the quality of air indoors, up to 3000 ft²
- Customizable to your environment, using either the included remote or the controls on the front of the unit.
- Intelligent control alerts you when normal maintenance needs to be performed or service is required.

UNIT FEATURES

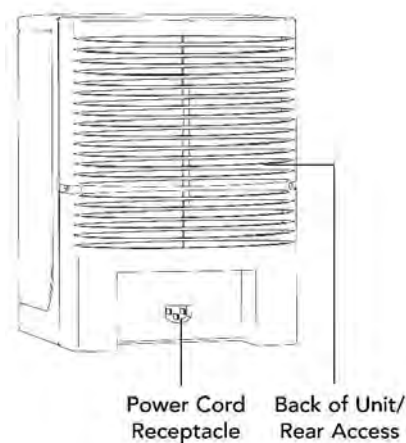
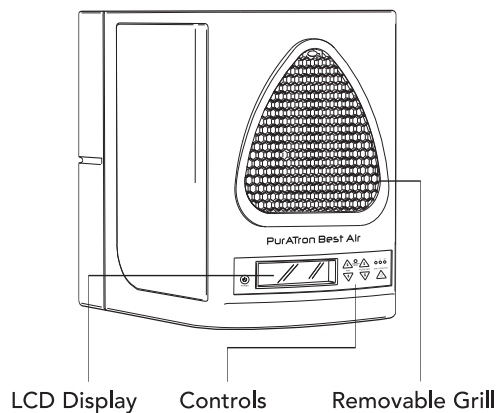

INSPECTION & INSTALLATION

1. Remove protective packaging.
2. Remove unit from shipping carton.
3. Remove all protective materials.
4. Check for shipping damage and loose or broken parts.
5. Read Owner's Manual thoroughly prior to installation.
6. Install batteries in remote.
7. Determine placement location for the unit and plug the unit into a working electrical outlet.
8. Using either the remote control or the Power button, turn the unit ON.

- Exclusive Photo-Catalyst-Oxidation Technology
- Needlepoint and RF Ion Generation
- Five Speed Fan
- Adjustable Purifier Control (High Mode only)
- LCD Display
- Away Mode Function
- Maintenance Reminders
- Remote Control or Manual Operation
- Computer Style Cord
- Uses Standard Household Current
- Washable Purification Plate
- Washable Rear Lint Screen
- Replaceable PCO Cell
- Removable Front Grill

GENERAL OPERATION

The unit can be operated using either the remote or the control panel on the front of the unit. Both the remote and the control panel have the same functions.

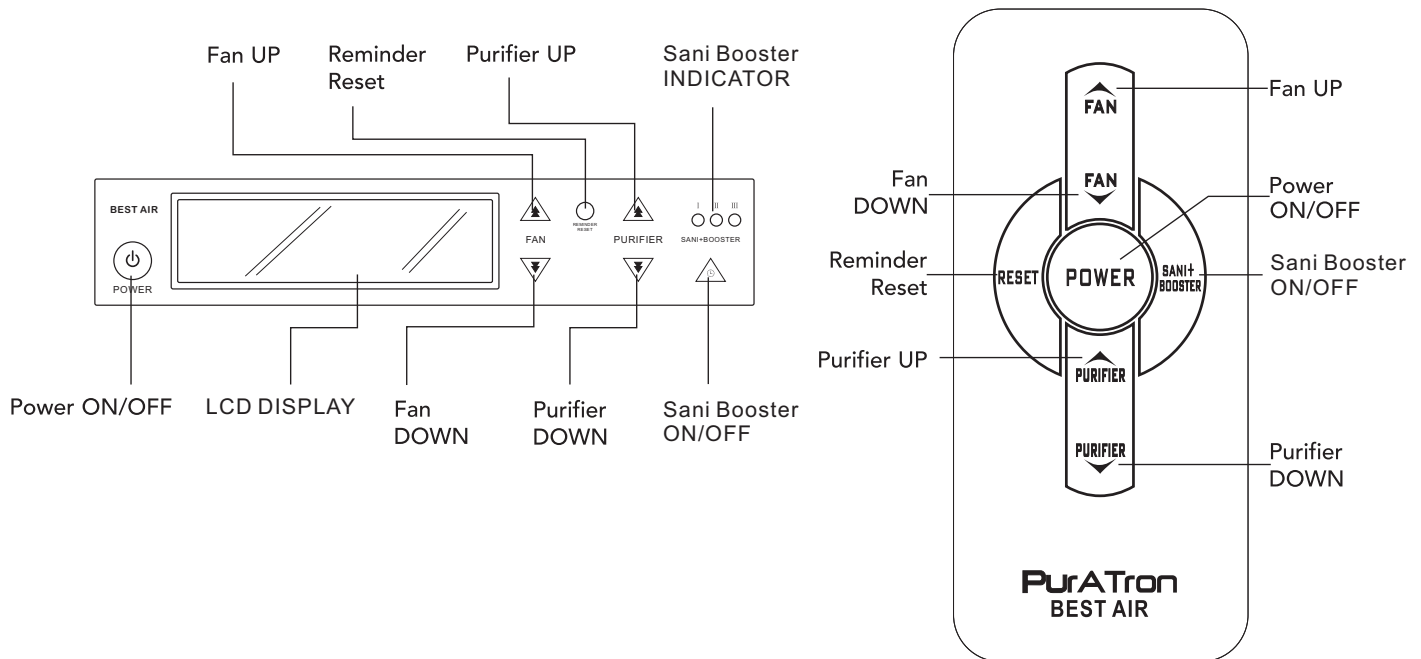

1. TURN ON THE AIR PURIFIER:

Press POWER button to turn the unit ON and OFF. The UVC and Ionizer will automatically turn on when the POWER button is pressed.

2. ADJUST THE AIRFLOW SPEED:

Press Fan Up and/or Fan Down buttons to adjust the airflow speed from Speed 1 to Speed 5.

3. SET THE AIR PURIFYING STAGE:

Press Purify Up and Purify Down to adjust the purification level to its lowest setting (250 ft²) for the first 24 hours of operation. Then gradually adjust up (if needed) to the square footage of the indoor area.

NOTE: If you are continuously operating your central heating and air conditioning fan, or other ventilation system, set the coverage up to the total ventilated indoor area or set the coverage up to the size of the room. Do not exceed the size of the ventilated indoor area when setting the purifier level.

4. SET THE HIGHEST EFFICIENT MODE:

Press SANI+BOOSTER button to turn on and adjust the timer for the AWAY MODE function. Pressing the SANI+BOOSTER button once from the original condition will set 0.5 hour running at the mode, pressing it twice will be 1 hour, pressing the button three times will operate the mode for 2 hours. Pressing it four times will set the unit back to normal mode. The covering area at this mode will be up to 3000 square feet.

The SANI+BOOSTER function should be operated in unoccupied areas only.

5. RESET THE MAINTENANCE AND SERVICE TIME:

Press REMINDER RESET button on the control panel or the button RESET on the remote to reset original maintenance and service time after you perform the maintenance..

LCD DISPLAY

The LCD display shows all current settings as well as any maintenance reminders and service messages.

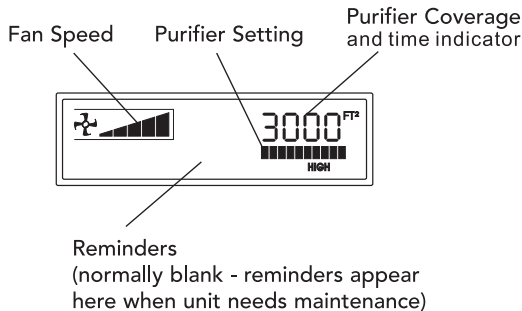

LCD SCREEN BACKLIGHT

As adjustments are being made, the LCD screen backlight will brighten and the screen will change. After 3 seconds without change, the backlight will return to normal.

If a maintenance reminder or a service reminder appears, the backlight will brighten and stay bright until the REMINDER RESET button is pressed or the service problem is corrected.

MAINTENANCE REMINDERS



REPLACE PLATE

The purifier plate is not functioning properly.

- Check the purifier plate to make sure it is installed properly.
- Replace the old purifier plate with a new one.

GENERAL MAINTENANCE

Periodic maintenance is required to insure that your Best Air by PurATron operates properly. The unit will display a PERFORM CLEANING reminder when it's time to perform regular maintenance. If you are operating your unit in a severely polluted environment, cleaning of the unit, purifier plate, PCO cell, and HEPA filter should be done more frequently. Shown here are some basic procedures that should be carried out to keep your unit running at top performance.

Failure to perform routine maintenance could adversely affect the proper function of the unit or cause it to fail prematurely.

NOTE: Any malfunction or damaged caused by neglect or unauthorized tampering could void the warranty.

CLEANING THE CASE;

Wipe the unit with a soft cloth dampened (not wet) with water. Do not use chemicals or solvents. Vacuum the front and rear grills periodically to remove any lint buildup.

CLEANING THE PCO CELL:

Remove the PCO cell and carefully vacuum accumulated lint. Do not wash the PCO cell. Damage from water may result.

MAINTENANCE REMINDERS (CONT.)



REPLACE PCO CELL

The purifier plate is not functioning properly.

- Check the PCO cell to make sure it is installed properly.
- Replace the PCO cell with a new one.

Note: The PCO cell should be replaced every two(2) years, even if the unit does not display this message.



PERFORM CLEANING

- Clean the rear HEPA filter
- Vacuum the PCO CELL
- Clean the purifier plate
- Vacuum the front and the rear grill openings.

Note: Be sure to press the REMINDER RESET button to clear the reminder following regular maintenance.

RESETTING THE REMINDERS

The only reminder you need to reset is the PERFORM CLEANING reminder (after performing maintenance, press the Reminder Reset button and the screen will momentarily display PERFORM CLEANING to let you know the reminder has been reset). All the other service reminders will clear automatically once the unit has been turned off and back on and the problem has been corrected.

CLEANING THE HEPA FILTER

You have two options to clean the HEPA filter:

1. When visibly dirty, simply remove the HEPA filter from the unit, and with a hand-held vacuum, remove the heavy particulate. This method will extend the life of the HEPA.
2. If step one doesn't clean the filter, Remove the HEPA filter from the unit, carefully Vacuum, then wash in hot water. Allow to dry prior to reinstalling, Replace if damaged.

CAUTION: *Unplug the unit before performing any maintenance procedures.*

CLEANING THE PURIFIER PLATE:

Remove the HEPA filter. Carefully remove the purifier plate from the plate guide by grasping the middle of the edge nearest to you and slowly pull it straight out.

If you are in an environment where there are fats, oils, or grease, such as in kitchen, start by cleaning with alcohol and a soft bristle brush. This will cut the grease without leaving a residue.

For all applications - Clean with a mixture of one part water and one part ammonia to remove contaminants. Place the plate into a shallow dish, and pour enough of the water/ammonia solution into the dish to just cover plate.

Allow the plate to soak for no more than 10 minutes.

CAUTION: *Damage may result from soaking the purifier plate longer than 10 minutes*

CHANGING THE PCO CELL:

The PCO cell should be changed when REPLACE PCO CELL appears on the display, or every two(2) years, whichever comes first. To change the PCO cell, follow the instructions on pages 7.

CHANGING THE FUSE:

The fuse may be accessed by unplugging the cord from the back of the unit, removing the back cover of the unit, then pulling, or if necessary, gently prying the fuse out using a small, straight screwdriver.

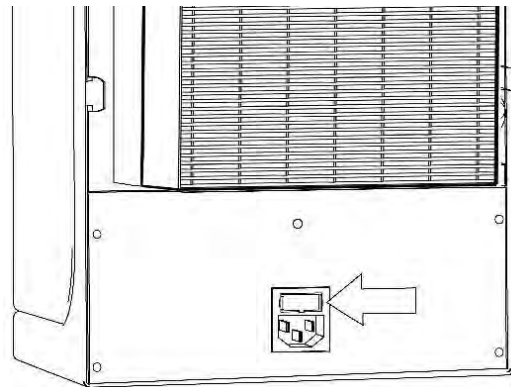

110 volt models -
use 1.6 Amp slow blow fuse

SEE PAGE 7 FOR REMOVAL AND INSTALLATION INSTRUCTIONS
See next page for back cover removal instructions

REMOVING THE REAR LINT SCREEN

To Remove:

Rear Lint Screen
follow steps 1 - 5

Purifier Plate
follow steps 1 - 6

PCO Cell
follow steps 1 - 10

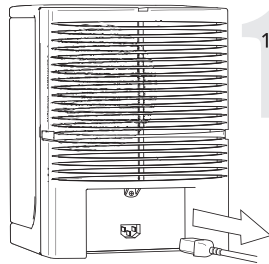

1. Unplug unit.

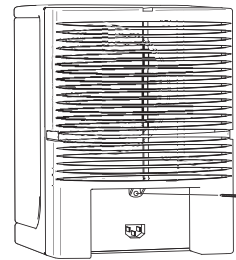

2. Remove the back cover screw.

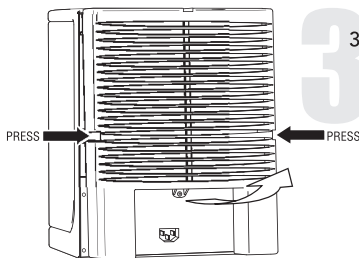

3. Remove back cover. Press the sides to unlatch, then tilt the bottom out to remove.

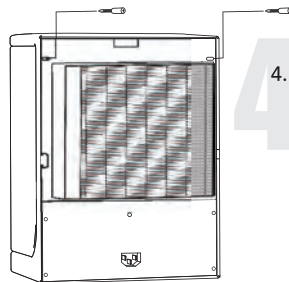

4. Remove two thumbscrews securing the top of the lint screen.

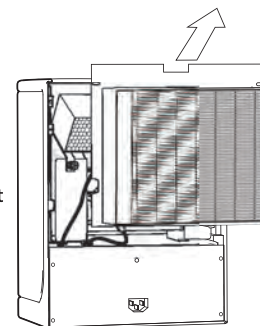

5. Remove the lint screen by pulling back the top, then lifting up and out.

REMOVING THE PURIFIER PLATE & PCO CELL

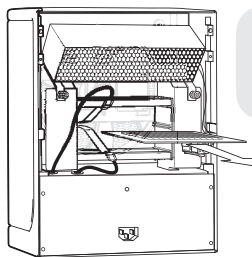

6. To remove the purification plate, grasp edge of plate in the center and gently pull out.

NOTE: If the plate is difficult to remove, gently press down on the lower metal contact tab.

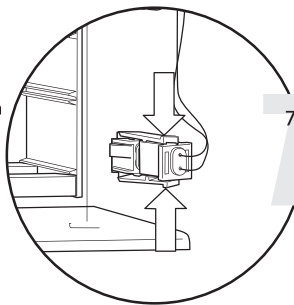

7. Unlock the PCO Cell connector by pressing on the connector's locking tabs.

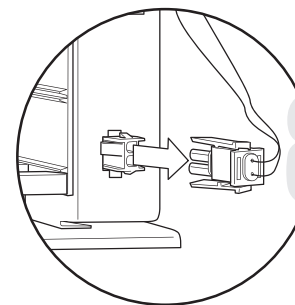

8. Pull the connector straight out to unplug.

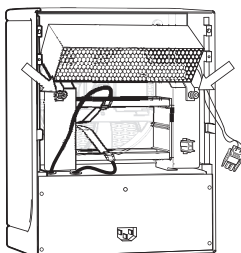

9. Remove two (2) thumbscrews.

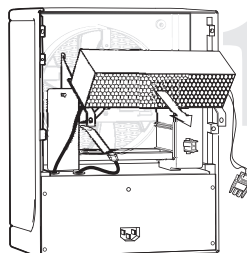

10. Slide the PCO Cell down and out of unit.

WARNING: Do not operate the Best Air by PurATron without the rear lint screen and back cover properly installed.

INSTALLING THE PCO CELL & PURIFIER PLATE

To Install:

Rear Lint Screen
follow steps 5 - 9

Purifier Plate
follow steps 4 - 9

PCO cell
follow steps 1 - 9

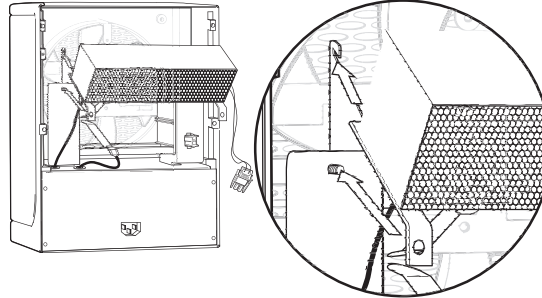

1. Slide the PCO cell up and into the unit. Be sure the back lip of the PCO cell engages the two slotted protrusions at the rear of the plate cage, and that the angle brackets and studs are correctly aligned.

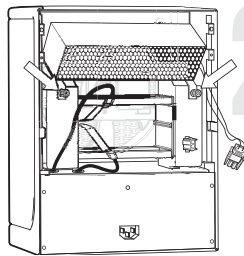

2. Replace the two (2) thumbscrews and tighten.

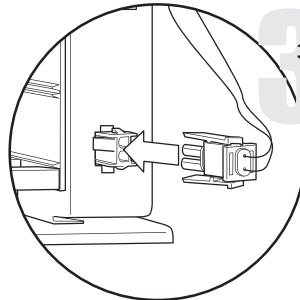

3. Insert the PCO cell connector into the plug on the plate cage. Press the connector firmly until the two tabs lock into place.

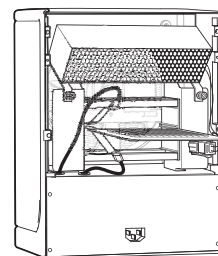

4. Gently insert the purifier plate between the guides (inside the cage) until it stops. When installing the purification plate, be sure the metal tabs are making contact with the screen on each side of the plate.

INSTALLING THE REAR LINT SCREEN

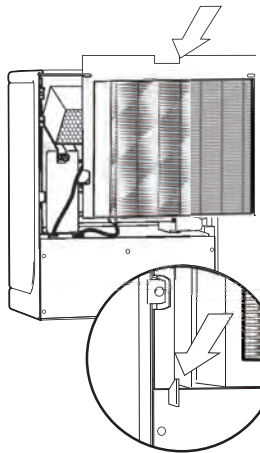

5. Replace the rear lint screen, inserting the bottom of the lint screen first.

Note: The bottom of the rear lint screen is held into place by two alignment guides (see inset).

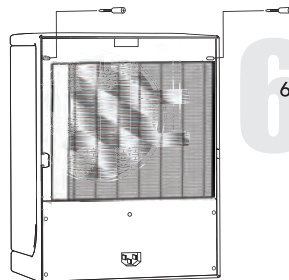

6. Secure the top of the lint screen by replacing the two (2) lint screen holder thumbscrews.

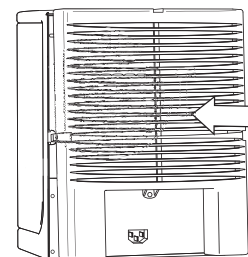

7. Replace the back cover by snapping into place.

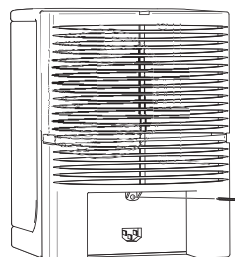

8. Replace the back cover screw.

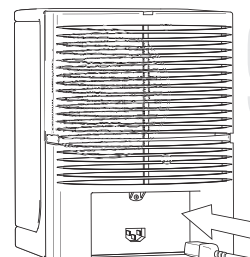

9. Reinstall the power cord.

WARNING: Do not operate the Best Air by PuraTron without the rear lint screen and back cover properly installed.

For disassembly instructions, see page 7.

TROUBLESHOOTING

Do not attempt to disassemble the unit. This will void the warranty of the product.

INDICATORS OF OPERATION:

When the unit is on, the LCD display will show either the fan setting and NORMAL, or the fan setting, purifier setting, and square footage. If the unit is in Away Mode, it will display AWAY MODE plus the hours and minutes remaining. See page 4 for more information.

TROUBLESHOOTING - WHAT TO LOOK FOR FIRST.

1. Unit does not operate.

- Plug the unit in.
 - Make sure the outlet is still active.
 - Make sure the rear lint screen and back cover are installed properly.
 - Make sure the fuse does not need to be replaced.
- #### 2. I have plugged in the unit, press the ON button on the remote (or the unit), and nothing happens... what's wrong?
- Make sure the power cord is inserted completely into the receptacle on the back of the unit.
 - Make sure the electrical outlet is capable of providing power to the unit.
 - Check to see if the proper fuse is installed and that it is operational.

If you are continuously operating your central heating and air conditioning fan, or other ventilation system, set the coverage up to the total ventilated indoor area or set the coverage up to the size of the room. Do not exceed the size of the ventilated indoor area when setting the purifier level.

Please note: The AWAY MODE should be operated in unoccupied areas only. "Unoccupied areas" includes pets. Some pets, like humans, may experience adverse reactions from exposure to increased levels of ozone and should not be present during Away Mode operation.

3. The fan is operating but the purifier plate is not working...

What's wrong?

- The unit is in Normal Mode (press the purifier UP to activate the ozone working.)

- If The unit is displaying a REPLACE PLATE message, check the purifier plate for serviceability. If it is cracked or broken, the purifier plate will require replacement. Ensure maintenance procedures required for the purifier plate have been performed according to the "Maintenance" section of this Owner's Manual. Order new purifier plate from you place of purchase.
 - The electrical stainless steel contacts are not contacting the screen portion of the purifier plate. Unplug and inspect the unit for any loose connections.
- #### 4. The purifier plate is making noise, has a burning smell, and/or appears to arc or spark. What is the problem?
- The purifier plate is most likely cracked. The unit will display a REPLACE PLATE message. Refer to the answer for question #3 as it would apply to this question also.
- #### 5. The UV lamp is not functioning/I'm getting a "Replace PCO cell" message.
- Check PCO cell for proper installation.
 - Replace the PCO cell.

CAUTION: Do not look directly at the glowing lamp. Prolonged exposure, even to reflected UV light, can cause eye damage according to the American Conference of Governmental Industrial Hygienists (ACGIH) Standards. Best air by PurAtron emits UV light which can cause eye damage if the light were looked at continuously, for 20 minutes or more, at a distance of one (1) inch or less.

6. What are the most typical application problems?

- Symptom: A belief that the proper equipment is placed in the environment and the equipment appears unsuccessful.
Problem: Lack of air movement, improper placement of the unit.
- Symptom: Strong odors still remain within the environment after placement.
Problem: Purifier setting is too low, improper placement of the unit, or the source of the odor has not been eliminated.
- Symptom: A strong odor of ozone is present within the environment.

Problem: Too much Ozone accumulation, within the environment, as a result of improper purifier control setting, and/or lack of air movement.

7. Air flow is restricted or reduced.

- The unit may be placed next to objects that could obstruct the air flow.
- The rear lint screen, back cover and front grill may not be clean.

- The PCO cell may not be clean.

8. How can I tell if the PCO cell is functioning?

- The PCO cell will produce a glow that is visible through the front grill under low light conditions.

Very Important!
PLEASE KEEP THIS INFORMATION WITH
YOUR INSTRUCTION MANUAL

- In the unlikely event that your unit does not appear to be working properly, you may contact your Sales Representative for immediate assistance
- Prior to your call, we encourage you to visit our service related website www.edenpureservice.com for numerous troubleshooting tips and service instructions.
- If you are unable to reach your Sales Representative and www.edenpureservice.com does not answer your questions, you may contact our Resource Partner's Customer Service Team by calling **1-866-786-8946** or emailing us at custserv@rppurchase.com. Please have your proof of purchase handy when you make your call or Resource Partner will be unable to assist you. The information is necessary for us to help you is on your proof of purchase.

Thank you!

Suarez Corporation Industries
Resource Partners
7800 Whipple Ave. NW
North Canton, Ohio 44720-6928

THREE YEARS LIMITED WARRANTY

WARRANTY:

THIS PRODUCT IS WARRANTED to the original purchaser or gift recipient, to be free from defects in workmanship and materials under normal use and service, for a period of three years from the date of purchase.

LIMITATIONS:

ALL WARRANTIES IMPLIED BY LAW, INCLUDING THE IMPLIED WARRANTIES OF MERCHANTABILITY AND FITNESS FOR A PARTICULAR PURPOSE, ARE EXPRESSLY LIMITED TO THE DURATION OF THE WARRANTY SET FORTH ABOVE. Some jurisdictions do not allow limitations on the length of the implied warranty, so the above limitation may not apply to you.

IN NO EVENT SHALL THE COMPANY BE RELIABLE FOR ANY INCIDENTAL OR CONSEQUENTIAL DAMAGES, LOSS OF PROFIT, OR MEDICAL EXPENSES CAUSED BY ANY DEFECT, FAILURE, MISUSE, OR MALFUNCTION OF THE PRODUCT.

Some jurisdictions do not allow the exclusion of limitation of incidental or consequential damages, so the above limitation or exclusion may not apply to you. The Company will not responsible for damages or losses, direct or indirect, caused by misuse, abuse, accident, negligence, conditions of transportation or storage, or failure to follow instructions. The Company will not be responsible for for any written or oral statements made that are inconsistent with this written warranty, or which are misleading or inconsistent with the facts as published by the Company in the Literature of specifications.

WARRANTY RESTRICTION:

This warranty is invalid if the factory – applied serial number has been altered or removed from the product.

Please clip and return warranty card below

SCI Resource Partners' Warranty Registration

Please return this card within 30 days of purchase to activate your warranty. Thank you.

E-mail Address _____ @ _____

First name _____ M.I. _____ Last name _____

Street _____ Apt# _____

City _____ State _____ Zip code _____

Model purchased _____ Serial# _____

Date of purchase _____ Place of purchase: _____

Name of Representative or Service Center: _____

Are you interested in coming additional income? Yes _____ No _____

Phone: _____ Best time to contact you _____