

KEG KING



KEGMAS^TER™ XL

Single Door Four Keg Kegerator



User Instruction Manual

Designed & Engineered by Keg King



WARNINGS AND GENERAL SAFETY



Risk of Fire! Flammable materials.

- ▲ DO NOT operate if the power supply cord is damaged.**
To avoid a hazard, the power cord **MUST** be replaced by the manufacturer, a service agent, or similarly qualified persons.
- ▲ When positioning the appliance, ensure the power supply cord is not trapped or damaged.**
- ▲ DO NOT locate multiple portable socket-outlets or portable power supplies at the rear of the appliance.**
- ▲ The Refrigerant used for the appliance is flammable. When disposing of the appliance, keep away from any fire source. The appliance must be recovered and disposed of by a qualified company. To prevent harm and damage to people, property, and the environment, DO NOT dispose of by combustion.**
- ▲ Beware of electricity around liquids! Ensure power cords are placed well away from any potential spills and pooling condensation.**
- ▲ DO NOT power up the refrigeration unit until it has rested upright for 24 hours. Failure to do so will void the Warranty!**
- ▲ The appliance contains ventilation holes in the outer walls. Ensure that any enclosure or surrounding structure provides 100mm clearance to the rear and sides of the appliance. Keep the vents clear of obstruction. Failure to do so will void the Warranty!**
- ▲ This refrigeration unit may require occasional manual defrosting. DO NOT scrape any ice or frost from the inside walls or cold plates. DO NOT use mechanical devices or other means to accelerate the defrosting process, other than those recommended by the manufacturer. Doing so may damage the unit and void the Warranty!**
- ▲ DO NOT damage the refrigerant circuit.**
- ▲ DO NOT store explosive substances such as aerosol cans with a flammable propellant in this appliance.**
- ▲ Leaking CO₂ gas can cause suffocation. Always use CO₂ in a well-ventilated open area, in case leaking occurs. Never exceed gas pressures of 40psi with your kegs system.**
- ▲ DO NOT use electrical appliances inside the food storage compartments of the appliance, unless they are of the type recommended by the manufacturer.**
- ▲ This appliance can be used by children aged 8 years and above or by persons with reduced physical, sensory, or mental capabilities or those lacking experience and knowledge ONLY with appropriate supervision or instruction concerning safe use of the appliance and the hazards involved. Children SHOULD NOT play with the appliance. Cleaning and maintenance SHOULD NOT be performed by children without supervision. Children aged from 3 to 8 years CAN load and unload refrigerating appliances.**

▲ TO AVOID CONTAMINATION of food, please respect the following instructions:

- **DO NOT** leave the door open for long periods of time. Doing so can cause a significant increase of the temperature inside the appliance.
- If the refrigerating appliance is to be left empty for long periods, switch off, defrost, clean, dry, and leave the door open to prevent mould from developing inside the appliance

▲ This appliance is intended for INDOOR USE ONLY in household and similar applications such as

- staff kitchen areas in shops, offices, and other working environments
- farmhouses and for client use in hotels, motels, and other residential type environments
- “Bed & Breakfast” type environments
- catering and similar non-retail applications.



Please read the entire manual before operating.

These instructions are available in other formats. To request, please send an e-mail to info@keg-king.com.au

Table of Contents

Keg King.....	5
Introduction.....	6
Unboxing.....	6
Included Items.....	6
Getting to Know the Unit.....	7
The Control Panel.....	7
Initial Set Up.....	7
Door Orientation.....	8
Defrosting the KegMaster™ XL.....	9
Calibrating your KegMaster™ Series XL Kegerator.....	9
When to calibrate your KegMaster™ Series XL Kegerator.....	9
How to calibrate your KegMaster™ Series XL Kegerator?.....	9
About Kegs and Kegerators.....	10
Commercial Kegs.....	10
A-Type.....	10
D-Type.....	10
S-Type.....	10
Setting up Commercial Keg Couplers.....	11
Home Brewing Kegs.....	11
Ball Lock.....	11
Pin Lock.....	11
Setting Up Beer and Gas Lines.....	12
Using Stepless Clamps.....	12
Using Push-In Fittings.....	12
Plumbing your Kegerator.....	13
For Home Brew Kegs (Ball or Pin Lock Disconnects).....	13
For Commercial Kegs (usually 50L).....	13
Balancing your Keg System with CO ₂	14
Carbonation Level.....	14
Keg Storage Temperature.....	14
Beer line diameter and length adjustment.....	14
CO ₂ Conversion Chart.....	15
Attaching and Removing Taps from the Font.....	16
IMPORTANT – CO ₂ Pressure Check.....	16
CO ₂ Consumption Rate.....	16
Additional Keg King KegMaster™ Accessories.....	17
Troubleshooting.....	18
Specifications.....	18

Keg King



Whether you're a brewer or someone wanting to put drinks on tap in your own home, cafe or office, Keg King offers beverage creation and keg dispense solutions for amateurs and pros!

We don't just sell products, we innovate, design and manufacture our equipment to bring your beverage ambitions to life!

Our brands include:

- King Kegs, our Australian Made P.E.T. kegs
- Apollo P.E.T. Pressure Fermenters & Unitanks
- KegMaster™ Kegerators
- Atomic 15 Brewery Cleaners
- UltraTap Twist FC Faucets
- Spundy spunding valves
- the KegMaster™ Solstice Fridge
- and more!

Check the resellers map on our website to find where our products are available in North America, the United Kingdom, Europe, Australia, New Zealand, and South Africa.

<https://www.kegking.com.au/retailers>

Since 2009, Keg King's mission is to make the best brewing & dispensing equipment in the world!

Check out our helpful instructional videos on the **Keg King YouTube Channel**

<https://www.youtube.com/c/KegKingvideos>

Enjoy your KegMaster™ XL 4 Keg Kegerator!

Introduction

The KegMaster™ XL, released in May 2022, is a powerful and efficient refrigeration unit, with the capacity to hold 4 home brew kegs.

Please check our web site product pages for updated versions of our Instruction Manuals.

<https://www.kegking.com.au/>

Features

- Internal Volume: 160L
- Capacity: 4 x Cornelius (Corny) Home Brew Kegs
- Optional Castors for easy moving
- Reversible Door
- Font Fan with speed control
- Internal light
- Fits standard fonts (not included)
- Cold air hose for font cooling
- Suitable for free standing installations
- R600a Refrigerant

Unboxing

Please check that the unit is free of damage.

Included Items



The KegMaster™ XL kegerator



Fridge Shelf



Keg King MKX CO₂ regulator



Font Cooling Hose



Drip Tray

Getting to Know the Unit

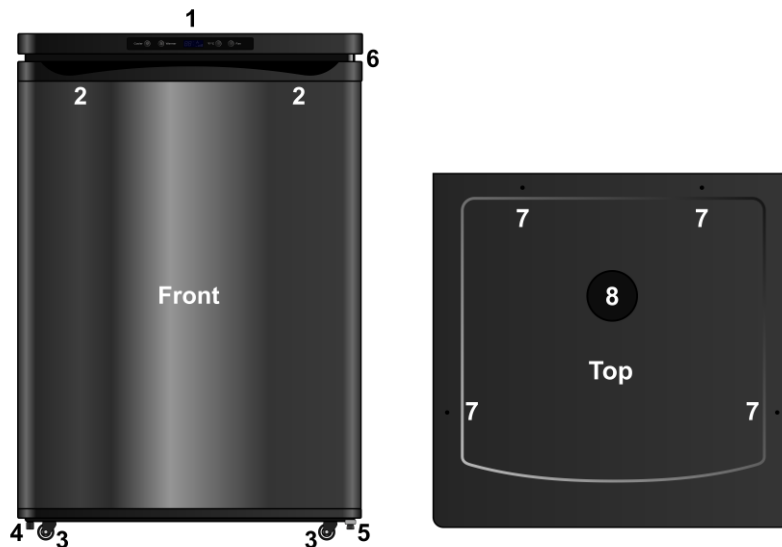

1. Control Panel
2. Door Handles
3. Castor Wheels (optional)
4. Leveling Foot

5. Door Hinge Bracket
6. Hinge Pin
7. Guard Rail mounting holes
8. Front hole and plug

The Control Panel



- | | | | |
|---------------|----------------------|--------------|---|
| Cooler | Decrease temperature | °F/°C | Switch display to Celsius (°C) or Fahrenheit (°F) |
| Warmer | Increase temperature | Fan | Adjust fan speed |

Initial Set Up



WARNING

DO NOT power up the refrigeration unit until it has rested upright for 24 hours.



WARNING

Allow 100mm clearance behind and on both sides of the refrigeration unit.

1. Ensure refrigeration unit has rested upright for 24 hours.
2. Ensure there is a minimum of 100mm (4 inches) clearance behind and on both sides of the refrigeration unit
3. Plug the refrigeration unit into mains power and turn power on.
4. Use the “°F/°C” button to switch between Celsius and Fahrenheit.
5. Use the “**Cooler**” and “**Warmer**” buttons to set the desired temperature.
6. Use the “**Fan**” button to set the desired Fan speed.

Door Orientation

The KegMaster™ XL door is reversible. It can be removed and re-attached to swing from the left or right, depending on your preference. If you wish to change the door orientation:

1. If the KegMaster™ XL unit is powered on, turn off the power and unplug it.
2. Prepare a soft towel or blanket for resting the KegMaster™ XL on its back.
3. To get access to the underside of the KegMaster™ XL, carefully tip it onto its back, resting it on the prepared soft towel or blanket.
4. Unscrew the **Leveling Foot** (4), which should be on the opposite side to the **Door Hinge Bracket** (5).
5. Remove the **Door Hinge Bracket** (5) by unscrewing the 2 bolts holding it in place.
6. Carefully slide the door approximately 10cm away from the upper hinge.
7. Remove the **Hinge Pin** (6) from the top corner of the door or unit.
8. Insert the **Hinge Pin** (6) in the hole in the opposite top corner of the door.
9. Slide the door back into place, ensuring that the **Hinge Pin** inserts into the retaining hole in the opposite top corner of unit.
10. Fit the **Door Hinge Bracket** to the opposite bottom corner of the door.
11. With the **Door Hinge Bracket** attached to the door, use the removed bolts to fasten the **Door Hinge Bracket** onto the opposite side of the unit, and tighten firmly.
12. Attach the **Leveling Foot** (4) where the **Door Hinge Bracket** was previously.
13. Tip the KegMaster™ XL unit back to the upright position.
14. The KegMaster™ XL will need to rest upright for 24 hours before power is reapplied.



WARNING

**DO NOT power up the refrigeration unit until it has rested upright for 24 hours.
Failure to do so will void the Warranty!**

Defrosting the KegMaster™ XL



WARNING

This unit **DOES NOT** automatically defrost and may require occasional manual defrosting.
DO NOT scrape any ice or frost from the walls or cold plates.
 Doing so may damage the unit and void the Warranty!



NOTE: Excessive ice buildup reduces the efficiency of the unit

For tips on how to limit ice and frost buildup please see our Troubleshooting section.

If excess ice or frost has formed on the inside of the KegMaster™ XL...

1. Turn the unit off at the mains power
2. Wait an hour or more for the ice to melt. This can take up to a couple of days, depending on how much ice has accumulated.
 A hairdryer may be used, to speed up the process, by gently blowing warm air at the ice.
3. Wipe any liquid or moisture from the internal walls, floors, and ceiling, using an absorbent cloth or towel
4. Turn the unit's power back on.

If excess ice is forming too regularly, see our Troubleshooting tips

Calibrating your KegMaster™ Series XL Kegerator

When to calibrate your KegMaster™ Series XL Kegerator

If your kegerator is freezing the chill plate on the inside with a thick layer or ice, it is recommended to set the calibration at -3 and see if the situation improves.

If the KegMaster™ is not cold enough, it is recommended to set it to +2 and see if the situation improves.

How to calibrate your KegMaster™ Series XL Kegerator?



1. Press and hold both the “**Cooler**” and “**Warmer**” buttons for 5 seconds until the temperature display flashes SC.
2. Release those buttons and press the “**°F/°C**” button.
3. The display now shows the calibration factor, and you can change it with the “**Cooler**” and “**Warmer**” buttons.
4. Once it is at the desired value press the “**°F/°C**” button again to save it.

About Kegs and Kegerators

Kegerators can be used for different keg types and it's important that you understand what types of kegs are available and the types of fittings that are required for each type. You will need to customize your kegerator to suit the kegs that you want to dispense. The keg types can be split up into two main categories: Commercial and Home Brewing Kegs

Commercial Kegs



Commercial Kegs such as the one on the left are usually used by commercial breweries and in Australia are mainly sold as 50L kegs. However, smaller sized kegs do exist, such as 20L, 25L and 30L kegs.

Commercial kegs use several different coupler types as shown below, with the most common types being the A, D and S-type couplings.

90% of all 50L commercial kegs in Australia will use either A or D-types. The S-type is most often used for imported beers from Europe or Asia.

The device to connect your beer and gas line to the keg is called a “Keg Coupler”. Make sure to know what type of keg coupler you need before purchasing the equipment so you can easily be supplied with the correct one.

A-Type

Also known as the “German Slider”, this type of keg is used by Toohey, Coopers, West End, Little Creatures, XXXX and any beer made by Lion Nathan.

To use this keg coupler, just slide the coupling over the top of the keg and engage the handle on the keg coupler.

This is the most common keg coupler type in Australia and approximately 45% of kegs in Australia would use this coupling type.



A-Type Keg



A-Type Coupler

D-Type

Also known as an American Sankey, this type of keg is used by VB, Carlton Draught, and any beers made by Carlton United Breweries.

To use the coupler just push the coupler against the top of the keg, twist clockwise firmly then depress the handle to tap the keg.

About 40% of kegs in Australia would use this coupling.



D-Type Keg



D-Type Coupler

S-Type

This keg coupler is often confused with the D-type keg coupling. It looks very similar however the “well” in the middle of the coupling is slightly deeper. These kegs are used by Asian, American, and other imported beers such as Asahi and Heineken.

To use the coupler just push the coupler against the top of the keg, twist clockwise firmly then depress the handle to tap the keg.

About 10% of kegs in Australia use this coupling.



S-Type Keg



S-Type Coupler

Setting up Commercial Keg Couplers

The gas enters the side of the coupler at about a 30-degree angle and the beer exits the keg coupler out the top of the keg coupler. For that reason, you will need to connect your gas line from your CO₂ regulator to the side of the keg coupler and the beer line from your tap to the top of the keg coupler.



Inside the keg coupler there may be two “one-way” valves. The one on the left is the one-way gas valve and the one on the right is the one-way beer valve. On a kegerator system these valves are not strictly necessary, and you do not know how to use them it is best to just take them out of the coupler.



If using barb-tails (pictured right), the keg coupler should include a hex nut, barb-tail, and rubber washer (as shown to the right).

Always ensure that the rubber washer is between the barb-tail and the coupler body.

Home Brewing Kegs



Home Brewing Kegs, such as those on the left are used by home brewers or small microbreweries. The sizes are typically 19L or 9.5L.

These kegs have 2 separate posts: one for the gas line (usually marked “IN”), and one for the beer line (usually marked “OUT”).

The posts are typically either “Ball Lock” or “Pin Lock”. The differences between these two types are explained as follows.

Ball Lock

Originally used by Pepsi for pre-mix syrups, about 85% of home brewers use this type of keg because they are easy to use, have a high availability of spare parts and are inexpensive.

The 2 posts on the kegs look very similar but are not compatible. As you can see on the photo to the left the gas post is slightly different shape to the liquid post. The gas post has a small ground notch (see arrow) which signifies the post is a gas post.

Similarly, the ball lock disconnects are also different from each other.

The grey should only be used for gas and the black should only be used for liquid.



Gas "IN" Post Liquid "OUT" Post

Ball Lock Posts
(on the keg)



Ball Lock
Disconnects

Pin Lock

Originally used by Coca Cola for pre-mix syrups, about 10% of home brewers use this type of keg.

The 2 posts on the kegs look similar but are not compatible. As you can see on the photo to the left the gas post has 2 pins on opposite sides of the post, and the liquid post has 3 pins equally spaced around the side of the post.

Similarly, the ball lock disconnects are also different from each other.

The disconnect with the grey base should only be used for gas and the disconnect with the black base should only be used for liquid.



Gas "IN" Post Liquid "OUT" Post

Pin Lock Posts
(on the keg)



Pin Lock
Disconnects

Setting Up Beer and Gas Lines

When Using Stepless Clamps

Stepless clamps grasp the beer line in a perfect circle meaning they do not pinch the line like worm style clamps. The stepless clamps come in different sizes so it is important you have the correct style of clamp for the beer line and barb fitting that you are using. These clamps are a single use item.



To use the clamps the best tool for the job is clamp tool (shown below in photo to left). These tools can be purchased separately (Part number 6530). If you do not have one of these tools the wire cutters (shown below to the right) will do an adequate job.

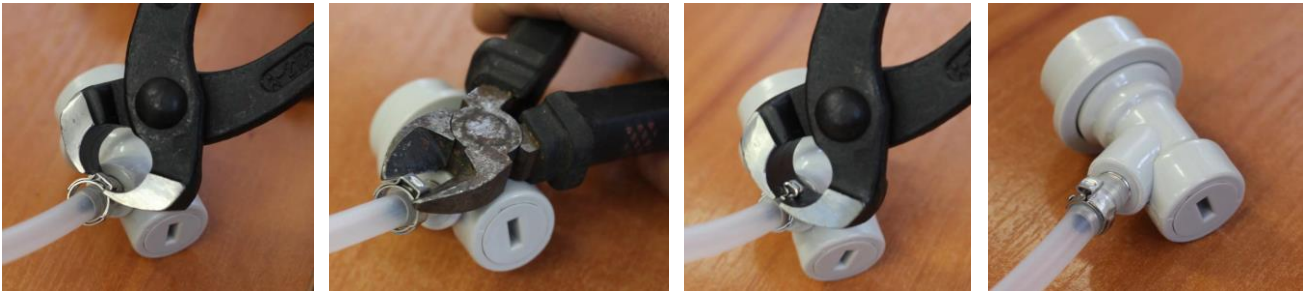

As shown above, all that is required is a quick single clamp with the tool and the job is done.

When Using Push-In Fittings



Push-In fittings are a great convenient alternative to using clamps on your lines.

Using an MFL disconnect and a premium FFL to 8mm push-in fitting, just screw the threaded end of the push-in fitting firmly onto the MFL thread of the disconnect. Then push your 8mm line firmly into the other end of the push-in fitting.



WARNING

To avoid leaks, ensure your beer and gas lines are cut cleanly and square.

Plumbing your Kegerator

For Home Brew Kegs (Ball or Pin Lock Disconnects)

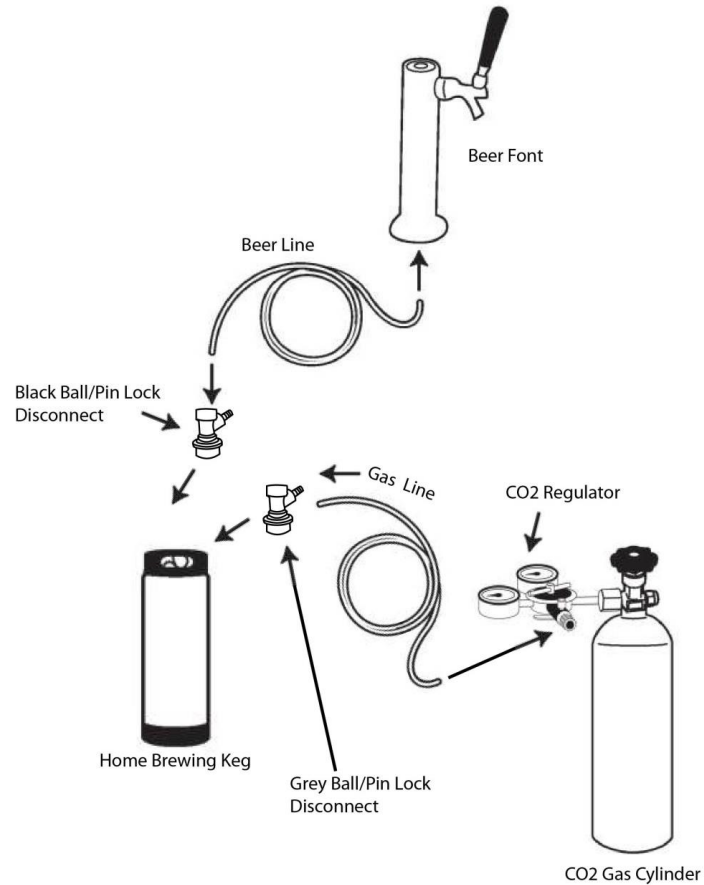

For Commercial Kegs (usually 50L)

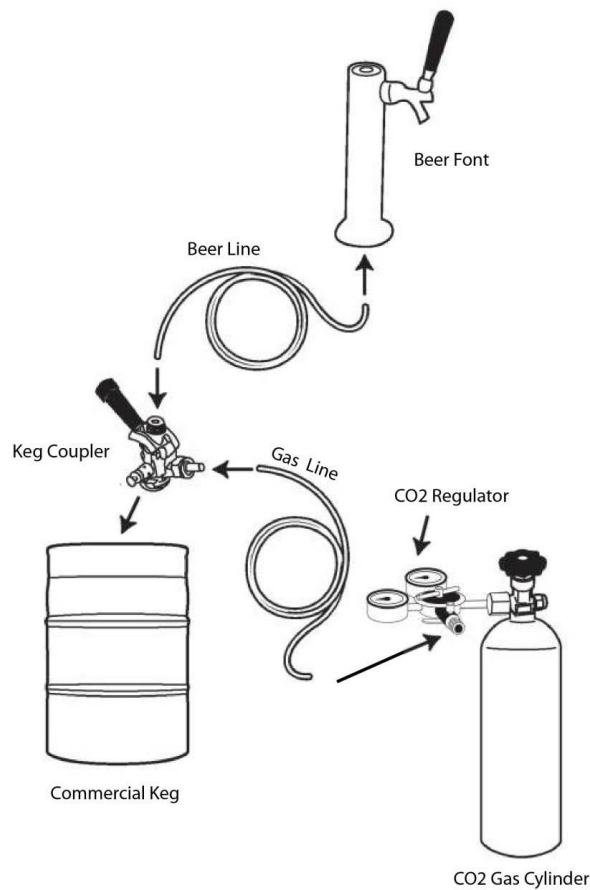

Balancing your Keg System with CO₂

Balancing your keg system is vital for optimum draft beer performance and is especially important when using CO₂ to dispense the beer. To balance your keg system correctly we must first understand Carbonation Level and Keg Storage Temperature.

Carbonation Level

Different beers are carbonated at different levels. The carbonation is measured in “volumes of carbonation”. Most draft beers have a carbonation level of about 2.6-2.8 volumes of carbonation. (see Table 1.1).

Keg Storage Temperature

Keg Storage temperature is best measured using a thermometer. Put a full glass of water in the fridge with the keg for 2hrs with a thermometer in the glass. Take a reading with the thermometer. This will give a true reflection of the keg storage temperature. In order to pour without excessive head, the keg storage temperature of most beers should be between 0°C up to 2.5°C. Some very lightly carbonated beers such as English Ales can be dispensed as high as 8°C.

Once you know what carbonation level is (if you do not know assume 2.6 volumes of carbonation) and your keg storage temperature use Table 1.1 to work out the correct dispense pressure. For example, if your keg storage temperature is 1C and the carbonation level is 2.6 volumes then the equilibrium pressure is 70kPa (10.2PSI). The dispense pressure should be 10% above the equilibrium pressure. So, you should set your regulator dispense pressure at 77kPa (11.2PSI).

Setting your dispense pressure below the equilibrium pressure will cause the beer to go flat over time. Setting the dispense pressure above the equilibrium pressure will cause the beer to become more carbonated over time.

NOTE: Many people make the mistake of using the keg dispense pressure to increase or decrease the flow speed of the beer out of the tap. **THIS IS INCORRECT.** When using CO₂ to dispense, the dispense pressure must be set according to Table 1.1. The method to adjust the speed of flow is to adjust the beer line length and diameter.

Beer line diameter and length adjustment

The beer line on a kegerator is not just a hose to get beer from the keg to tap. It also performs the important function of applying “flow resistance”. With too little flow resistance the beer will come out of the tap too fast. With too much flow resistance the beer will come out of the tap too slow. Small internal diameter (ID) beer line will apply more flow resistance and longer beer line will also apply more flow resistance. Most domestic systems work well with the following line length/diameter:

4mm ID Beer Line: 1.5-2.5 Meters

5mm ID Beer Line: 3-4.5 Meters

6mm ID Beer Line: 5-10 Meters

Small ID beer line is often the best choice for kegerators as it means the customer can use a shorter beer line which is less messy inside the fridge. It also minimizes the amount of beer sitting in the beer lines.

Using 4mm ID beer line you will have 12.5ml per meter in the beer line and a total of approx. 22.5ml.

Using 5mm ID beer line you will have 20ml per meter in the beer line and a total of approx. 70ml.

Using 6mm ID beer line you will have 28ml per meter in the beer line and a total of approx. 210ml.

For the above reasons 4mm ID beer line is often the best choice however the small ID makes it difficult for some customers to fit the ID over the barb fittings on the keg coupler or ball lock disconnects.

If using 4mm ID, the user may need to stretch the beer line open slightly so it can fit onto the barbs of some of the fittings. The perfect tool for this job is a set of needle nose pliers. Heat the beer line in some boiling water for 30 seconds to soften then push onto the needle nose pliers to stretch the internal diameter. Open the handles on the pliers to further stretch the beer line.



CO₂ Conversion Chart

		Grams Per Litre of dissolved CO ₂ (g/L)											
		4.0 g/L	4.4 g/L	4.8 g/L	5.2 g/L	5.6 g/L	6.0 g/L	4.0 g/L	4.4 g/L	4.8 g/L	5.2 g/L	5.6 g/L	6.0 g/L
Temperature		Volumes of Desired Carbonation											
		2	2.2	2.4	2.6	2.8	3	2	2.2	2.4	2.6	2.8	3
°C	°F	Equilibrium Pressure kPa						Equilibrium Pressure PSI					
0	32	24	37	50	63	76	89	3.5	5.4	7.3	9.1	11.0	12.9
1	34	29	43	56	70	83	96	4.2	6.2	8.1	10.2	12.0	13.9
2	36	34	48	62	76	90	104	4.9	7.0	9.0	11.0	13.1	15.1
3	37	40	54	68	83	97	111	5.8	7.8	9.9	12.0	14.1	16.1
4	39	45	60	74	89	104	119	6.5	8.7	10.7	12.9	15.1	17.3
5	41	50	65	81	96	111	126	7.3	9.4	11.7	13.9	16.1	18.3
6	43	56	71	87	102	118	134	8.1	10.3	12.6	14.8	17.1	19.4
7	45	61	77	93	109	125	141	8.8	11.2	13.5	15.8	18.1	20.5
8	46	66	83	100	116	132	149	9.6	12.0	14.5	16.8	19.1	21.6
9	48	72	89	106	123	140	157	10.4	12.9	15.4	17.8	20.3	22.8
10	50	78	95	112	130	147	164	11.3	13.8	16.2	18.9	21.3	23.8
11	52	83	101	119	137	154	172	12.0	14.6	17.3	19.9	22.3	24.9
12	54	89	107	125	144	162	180	12.9	15.5	18.1	20.9	23.5	26.1
13	55	95	113	132	151	169	188	13.8	16.4	19.1	21.9	24.5	27.3
14	57	101	120	139	158	177	196	14.6	17.4	20.2	22.9	25.7	28.4
15	59	106	126	145	165	184	204	15.4	18.3	21.0	23.9	26.7	29.6
16	61	112	132	152	172	192	212	16.2	19.1	22.0	24.9	27.8	30.7
17	63	118	139	159	179	200	220	17.1	20.2	23.1	26.0	29.0	31.9
18	64	124	145	166	187	207	228	18.0	21.0	24.1	27.1	30.0	33.1
19	66	130	152	173	194	215	236	18.9	22.0	25.1	28.1	31.2	34.2
20	68	136	158	180	202	223	245	19.7	22.9	26.1	29.3	32.3	35.5

Table 1.1 – Ideally set dispense pressure 10% higher than the “Equilibrium Pressure”

Attaching and Removing Taps from the Font

Attaching and removing the taps from the font may be necessary if you need to change the beer line or taps at any time throughout the life of the kegerator.



Step 1 Remove the cap from the top of the font.
(See photo to the left)

Step 2 Feed the beer line up through the bottom of the font and place through slimline nut and convex collet before going through the tap hole.
(See photo to the right)



Step 3



Attach beer line to back of the tap, then push the threaded shank of the tap into the tap hole.

Step 4

On the inside of the front, place the convex collet onto the tap shank, then tighten the slimline nut to the tap shank to secure to the font.



NOTE: It is important that the user does not over-tighten the faucet collar on the tap. Over tightening of this part will prevent the free and full movement of the tap handle. Over tightening will also restrict the tap handle movement preventing the tap from completely opening.

IMPORTANT – CO₂ Pressure Check

After setting up the kegerator it is important to do a CO₂ pressure check to make sure your system holds pressure. This is extremely important as it will determine that you have no leaks. This can be done in a few simple steps.

Step 1: With all your hoses and the keg connected turn the pressure on the CO₂ regulator up to 140kPa (about 20psi) then turn off the valve on the top of the CO₂ gas cylinder.

Step 2: Wait 2 hours and check that the pressure on the CO₂ regulator has not dropped since step 1. If the pressure has dropped over the 2-hour period then go over all the hose connections with soapy water and attend to any CO₂ leaks found, then repeat the above.

CO₂ Consumption Rate

The CO₂ cylinder that you use with your kegerator can be used for 2 purposes:

1. **Carbonating** your beer or other drink in the Keg.
2. **Dispensing** your beer or other drink from the Keg.

If you are brewing your own home brew, then you will most likely use the CO₂ gas cylinder to carbonate your beer. This will consume approximately 6 grams of CO₂ per Litre. If you purchase your beer from a commercial brewery, then it will already be carbonated.

Dispensing your beer will consume approximately 6 grams per litre as well regardless of whether you brewed it yourself or not.

Keg King sells 2 different CO₂ cylinder sizes:

1. **2.6kg Gas Cylinder**
For home brew this will carbonate and dispense approximately 200 Litres.
For commercial beer that comes already carbonated this will dispense about 400Litres
2. **6kg Gas Cylinder**
For home brew this will carbonate and dispense approximately 500 Litres.
For commercial beer that comes already carbonated this will dispense about 900Litres

Additional Keg King KegMaster™ Accessories



Fonts and Taps

The KegMaster™ XL comes standard without any fonts or taps.

Keg King sell a range of [fonts](#) and [taps](#)

The UltraTap Twist flow-control tap provides additional control when pouring your beer.

Castor Wheels

The lockable castor wheels provide extra maneuverability for your kegerator.



Guard Rail

If you store glasses on top of your KegMaster™ XL, a Guard Rail is helpful in keeping your glassware in place.



Stainless-Steel Drip Tray

If you prefer the “stainless” look, upgrade your plastic drip tray with the Stainless-Steel option.



Stainless-Steel Top

The KegMaster™ XL top can be replaced by an optional Stainless-Steel version, which offers a professional look that is more durable and easier to clean.



Tap / Faucet Plugs and Brushes

During periods where the kegerator is not used the faucets can be plugged to prevent contamination or fruit flies getting into the tap. This handy little device fits all tap sizes and shapes and is made from long lasting silicon (See photo to left).

We also sell a faucet brush that can be used to clean out the taps. (See photo to right)



Beer Line Cleaning Equipment



To keep your kegerator in top condition it is recommended to clean your beer lines out between kegs. Keg King supply cleaning chemicals that are perfect for the job. We also sell beer line cleaning caps (See photo to left) that you can use on an empty PET bottle and use this to clean out your beer lines or if you are using commercial keg couplers then you should try our 15 liter wash out kegs (see photo to right).



These useful parts will ensure you maintain the quality of your beer.



Troubleshooting

Issue	Remedy
Ice or frost forming inside the unit	See the “Defrosting the KegMaster™ XL” section
Ice forms too regularly	If excess ice forms too regularly: <ol style="list-style-type: none"> 1. Avoid opening the door unnecessarily. Opening the door introduces moist air that condenses and forms ice. 2. Ensure there are no gaps in the door seal that may allow ingress of moist air. 3. Ensure fonts and / or the font hole are well sealed from moist air ingress (especially with under-bench installs). 4. If the above has not helped, set the temperature to a slightly higher temperature, or try calibrating your KegMaster™ (see section “Calibrating your KegMaster™ Series XL Kegerator”) Colder temperatures increase moisture condensation and freezing.
The KegMaster™ is too warm	Set the temperature to a slightly lower temperature, or try calibrating your KegMaster™ (see section “Calibrating your KegMaster™ Series XL Kegerator”)
Beers pour with excess foam	Please see our article on reducing beer foam https://www.kegking.com.au/blog/post/help-my-taps-pouring-foam
Unit has no power	Check that your power outlet is working with another appliance
Unit is not cooling	Ensure you have 100mm clearance behind and on both sides of the unit
Excessive noise	Ensure there is nothing obstructing the fan
For other issues or if the above remedies do not solve the issue, contact info@keg-king.com.au	

Specifications

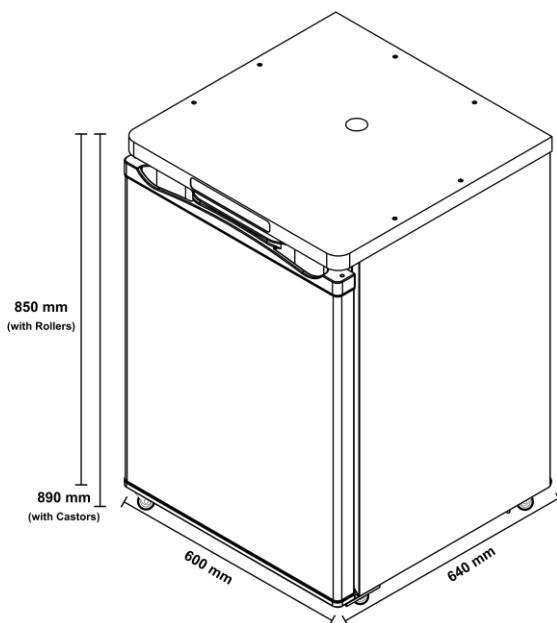

Height:	850 mm with rollers 830 mm without rollers 890 mm with castors
Width:	600 mm
Depth:	640 mm
Internal Height:	724.9 mm
Internal Width:	511.9 mm
Internal Depth:	405.1 mm
Volume:	160 L
Weight:	43 Kg
Power:	220-240V 50Hz
Climate Class:	T
Refrigerant:	R600a (40g)
Insulation:	Cyclopentane