



GSM (GSM-R) - Commander Plastic Bodied Heavy Duty Telephone



- Fully Integrated GSM-based Commander
- Internal Antenna as standard
- Robust and weather resistant: IP65
- Full keypad, CB and 1, 3 and 6 button programmable autodialler telephones
- Dual purpose design for wall or desk mounting, simple installation
- Large tactile buttons, easy to see and operate
- Inductive Coupler fitted as standard for hard of hearing
- Standard or Customised units
- Vandal Resistant Handset and Cord (with length options)
- CE Compliant
- Supplied with 12vDC Power Supply
- Acoustic Path Testing

Designed for indoor or outdoor use, the new GSM Commander offers wireless communications to provide a completely stand-alone telephone installation. The GSM phone greatly reduces installations costs by eliminating running wires. The battery and GSM terminal are housed inside the unit to provide a complete rugged telephone.

The unit can be mains, battery, or solar powered, with the internal lead-acid backup battery and phone working in temperatures of -20 to +60 degrees, ideal for hostile environments. The Quad-band GSM module covers wireless ranges across most of the globe.

Advanced features of the telephone include an internal memory for local digital recordings, and over-the-air updates and remote management to reduce site visits and maintenance costs.

The Commander family of telephones are tough, weather resistant units built to withstand abuse and environmental extremes. The Commander body is moulded in glass filled polyester to prevent rust and corrosion, and is simple to install.

Typical installations include civil construction sites, bus or rail stations, retail, and temporary events (festivals, construction, exhibitions), anywhere that laying cable is prohibitive.

Keypad Options: 15 button Full Keypad

The 15 button keypad versions include: **S** 'Microphone mute' or 'Silence', **LR** 'Last number redial'

6 button Auto diallers

These models are programmable via SMS. A microphone muting facility guards against unauthorised calls made with a remote MF tone pad. To make a call, simply lift the handset and press a single button. The pre-programmed number (up to 24 digits) will then dial automatically.

Hot Dial (0 Button)

Again programmable via SMS, simply lift the handset to automatically call a pre-programmed number.



External Antenna

Optional external antenna with 3 metre cable. Internal antenna is fitted as standard.



GAI-Tronics Telephony

GSM (GSM-R) - Commander Plastic Bodied Heavy Duty Telephone

GENERAL SPECIFICATIONS

Casing Material

Glass filled polyester.

Colours: yellow. Other colours by special order

Handset Material

Cyclopol with stainless steel spiral cord, or curled cord

Inductive coupling to hearing aids with T-switch

Keypad

Weathersealed tactile digital keypad. Silicone rubber material, resistant to most chemicals and solvents

15 full keypad. 0, 1, 3, 6 key autodial

Antenna

Quad-band SMA male, internally mounted

Operating temperature

(AC powered) -20° C to +60° C

(Battery powered, lead-acid) -20° C to +60° C

Auto switch-off: <-40°C or >+70°C

Weather Resistance: Up to IP65

Ringing Tone

Shrill warble tone 80 dBA @ 1 metre typical

Hookswitch

Electronic / magnetic with no visible moving parts

M.T.B.F.

Calculated to have an M.T.B.F. in excess of 50,000 hours using MIL-HDBK-217F Notice 2

Weight 3 kg approx

GSM/GSM-R

Dialling

MF (tone). User selectable

Dial Tone Factory programmable to local telco standard

Time Out

Enforces a fixed call maximum time limit to 6-8 minutes from lifting the handset. User selectable

Power supply

AC Adaptor 90-264VAC to 12VDC

Internal battery (4V sealed lead acid)

Up to 250 hours standby and up to 6 hours continuous talk time

Can be connected directly to Solar panel (12-24V) without additional charge controller

GSM Bands Quad-band GSM/GPRS/GSM-R

Remote programming

Auto-dial numbers, time-out and dial mode can be programmed

Configuration

Remotely programmable via SMS

Remote monitoring

Remote health-check and fault reporting, including handset integrity via SMS

OPTIONS

- Stub Antenna for compact installation
- Marine antenna for gain in hostile environments
- Rod antenna for omni-directional gain
- YAGI antenna for high gain (requires setup)
- 12VDC power supply
- 12VDC solar panel
- External antenna and cable

DIMENSIONS

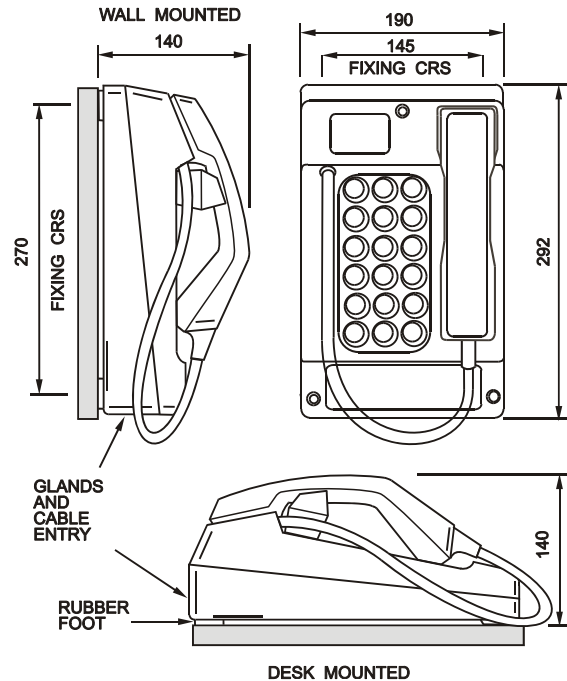

APPROVALS



This mark indicates compliance with the following directives:
Radio & Telecommunications Terminal Equipment Directive
1999/5/EC (R&TTE)

2011/65/EC ROHS 2 Directive



This mark indicates compliance for inductively coupling to
Hearing Aids having a 'T' switch position
Tested to ETS 300-381 and in accordance with ITU-T P37.

Approvals

R&TTE, GCF, RoHS compliant, WEEE Registered
For specific country approval, please contact GAI-Tronics

ORDER INFORMATION

For order please contact:

T: 01283 500500, F: 01283 500400,

E: sales@gai-tronics.co.uk

ITEM DESCRIPTION	PART NUMBERS
Commander GSM 0btn yellow	231-02-0000-212
Commander GSM 3btn yellow	231-02-0003-212
Commander GSM 15btn yellow	231-02-000F-212
Commander GSM 0btn yellow euro	231-02-0010-212
Commander GSM 3btn yellow euro	231-02-0013-212
Commander GSM 15btn yellow euro	231-02-001F-212
Commander GSM 0btn yellow solar	231-02-0020-212
Commander GSM 3btn yellow solar	231-02-0023-212
Commander GSM 15btn yellow solar	231-02-002F-212

OPTIONAL ACCESSORIES

Please ask for Brochure B150 or visit www.gai-tronics.co.uk



GAI-Tronics® - United Kingdom - Tel: +44 (0)1283 500500 - Fax: +44 (0)1283 500400 - www.gai-tronics.co.uk
GAI-Tronics® (Corporate) - USA - Tel: +1(610) 777 1374 - Toll Free: 800 492 1212 - Fax: +1(610) 796 5954 - www.gai-tronics.com
GAI-Tronics® S.r.l - Italy - Tel: +39 02 48601 460 - Fax: +39 02 4585 625 - www.gai-tronics.co.uk
GAI-Tronics® - Malaysia - Tel: +60 3 8945 4035 - Fax: +60 3 8945 4675 - www.gai-tronics.co.uk
GAI-Tronics® Austdac - Australia - Tel: 011 61 28 851 5000 - Fax: 011 61 29 899 2490 - www.austdac.com.au
An ISO 9001, ISO 14001, OHSAS 18001 Registered Company
The policy of GAI-Tronics is one of continuous improvement; therefore the company reserves the right to change specifications without notice.