

## Robust Construction

- All Weather Protection
- Vandal Resistant
- Tamper resistant fixings
- Highly Reliable Operation
- Simple installation
- Fast network connection
- Can mimic C.B. (Hot Line)
- GSM or GSM-R operation
- Self-monitoring and reporting
- Remotely programmable via SMS
- Various power options
- Tough Polyurethane Handset
- Low power consumption
- Full Keypad option



## RA708 Series Weather and Vandal Resistant Telephones

Providing a reliable and effective communications terminal when there is limited, or no infrastructure can often be costly and time consuming. The GSM range of hands free and handset telephones, as manufactured by DAC Limited, address this issue perfectly. Easy to install, fully programmable and designed to operate as a stand-alone telephone in even the harshest environments. Completely self-sufficient with on-board battery charged via a solar panel. These GSM Telephones have been designed to operate with minimal power requirements <math><4\text{mA}</math> and will connect to the GSM network in less than 4 seconds. The provision of call mimic dial tone and confidence tones ensures the user is presented with a familiar situation whilst possibly distressed due to an emergency. Additionally, these GSM Telephones are fully programmable, remotely via SMS, and will report on critical failures such as low power. Designed to be shipped complete to site ready to operate, with the only requirement being the insertion of an appropriate network SIM card. Perfect for many applications where an economical and reliable solution is required.

[sales@daclimited.co.uk](mailto:sales@daclimited.co.uk)

# TECHNICAL SPECIFICATION



**Speech/ Network Interface:**

Quad band GSM and GSM-R, supplied SIM Free

**Ringling:**

Frequency modulated, Piezo transducer, cadence as per incoming ringling.

**Power Supply:**

Options include: battery, mains power pack, solar.

**Time out:**

Programmable

**Temperature:**

Operating: -30° C to +60° C

Storing: -40° C to +70° C

**Relative Humidity:**

Up to 95% (non-condensing)

**Casing Material:**

Robust cast aluminium.

**Colours:**

Standard Yellow or Grey durable powder coat. [custom colours available]

**Programming:**

Remotely via SMS / PC.

**Safety:**

Manufactured to BS EN 60950

**Protection:**

Dust and Liquids to BS 5490: 1977 IP65

**Handset 'Wrench' Test:**

Curly Cord: 18kg Max. Armoured Cord: 150kg Max.

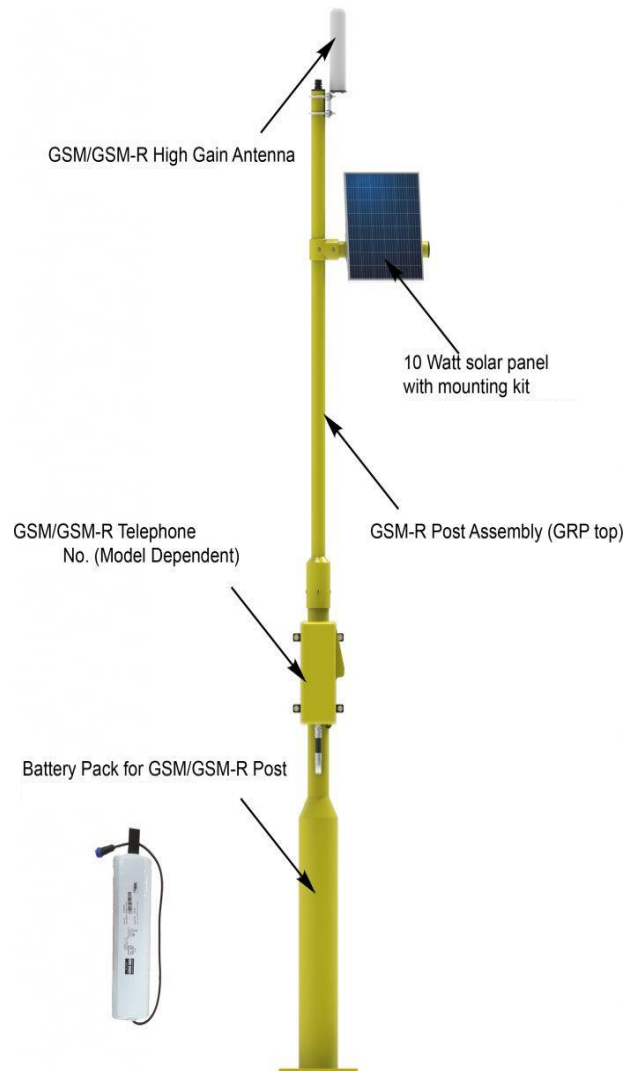

Mounting options:

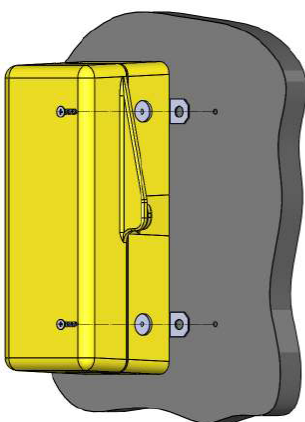

**Wall mounting:**

Use reducing washers supplied with telephone

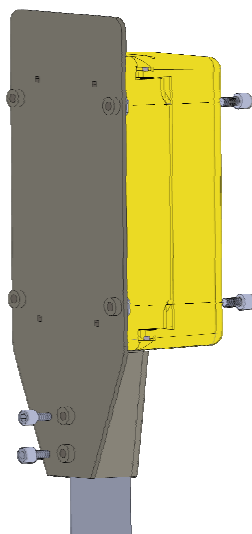

**Top of pole mounting:**

Top of pole mounting bracket available from DA

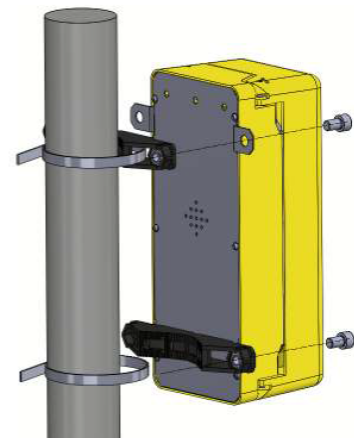

**Side of post mounting:**

Bracket kit (bands not provided)

