



AUTOMATIC CHECKWEIGHERS CW-4000 SERIES

Automatic equipment to check that a product's weight is within a defined weight range.



INFORMATION



DYNAMIC OR
STATIC
WEIGHING



REJECTION
OPTIONAL



UP TO
3 OUTPUTS



8,000 PLUS
MEMORY



TOUCH SCREEN
CONSOLE
OPTIONAL



ETHERNET



METROLOGICAL
VERIFICATION
OPTIONAL (EU)

Dibal CW-4000 automatic checkweigher, with optional rejection system, checks the correct weight of products without stopping the production line. If the weight is above or below the set range the equipment automatically rejects the product.

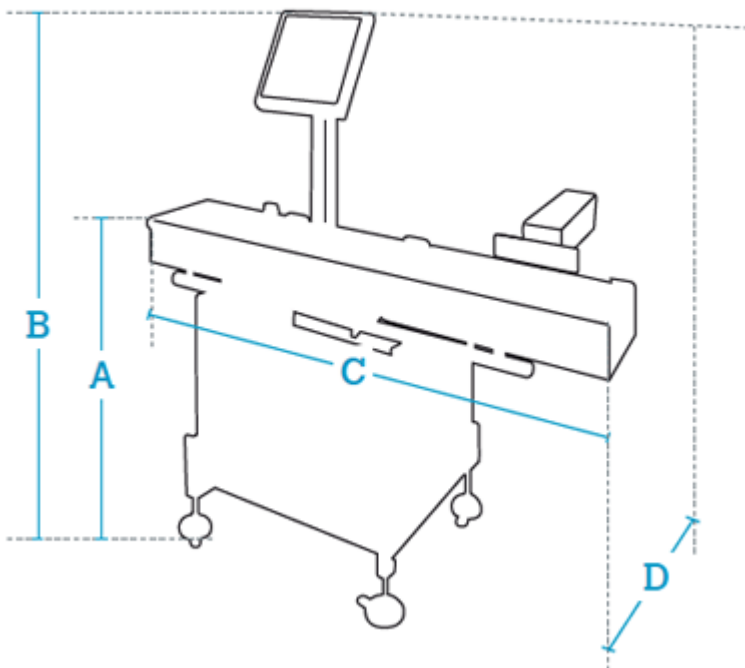

Data in mm

A	820 - 970 (adjustable legs)
B	1,350 - 1,500 (adjustable legs)
C	1,525 (with L400-L400-L600 conveyors)*

D 630 (for W280 conveyors)**

* These measurements correspond to the sum of the infeed and weighing conveyors and the optional conveyor for the rejection system with 1 pneumatic piston. For other sizes, contact us.

** For other sizes, contact us.

OUTSTANDING FUNCTIONS

- **Discrimination by weight checking.**
- **Orders management.**

WEIGHING

- **Type of weighing:**
 - Dynamic or static.
- **Ranges depending on the dimensions of the weighing conveyor:**
 - 6 kg / 2 g or 10 kg / 5 g with conveyor of up to L400 x W400 mm.
 - 15 kg / 5 g, 20 kg / 10 g, 30 kg / 10 g, 40 kg / 20 g or 60 kg / 20 g with conveyor of up to L600 x W500 mm.
 - 3 kg / 1 g or others, contact us.

REJECTION SYSTEM (OPTIONAL)*

- **Rejection system type**
 - “Air-jet®”.
 - Pneumatic piston.
 - Rotating blade.
 - Folding conveyor.
- **Number of rejectors:**
 - 1 or 2.
- **Position of the 2 rejectors:**
 - They can be located on the same side or opposite sides.

** All the rejection systems (pneumatic piston, “Air-jet®”, etc.) depend on the type of product/packaging, required speed, collection system, etc.; please always check with Dibal.*

CONSTRUCTION

- **Structure:**
 - AISI 304 stainless steel and anodized aluminium.
- **Belts:**
 - Material and characteristics: Polyurethane, rigid or elastic depending on the equipment range. With FDA approval.
- **Console:**
 - Material: stainless steel.
 - “Qwerty” keypad and graphic backlit LCD display.

- 15" TFT touch screen, optional.

COMMUNICATION TO PC

- **Ethernet TCP/IP.**
- **RS-232.**

PC SOFTWARE

- **RMS:** For equipment configuration, production data management and back up (LBS).
- **DCS:** For production data management.
- **Integration tools:** See section on software.

POWER SUPPLY & COMPRESSED AIR

- **Electrical:** 230 V/50 Hz; 115 V/60 Hz.
- **Air:** max. 150 l/min (at 5-8 bar) (if rejection system is included).

POSSIBLE INTEGRATION WITH OTHER EQUIPMENT

- **Dibal LS-4000 automatic weigh-price labeller.**
- **Aligner.**
- **Misaligner.**
- **90° deflector.**

CUSTOM SOLUTIONS

At Dibal, we have professionals who work closely with our clients to design, develop and produce [customised solutions](#) in accordance with their specific needs. **Consult us!**

MODELS

CW-4200/350 (NO REJECTORS)

- 1 infeed and 1 weighing L350 x W200 mm conveyor.
- For products of up to L250 x W200 mm and up to 3 kg (in dynamic weighing). Up to L300 x W200 mm in static weighing.
- Without rejection system (check for options).
- **Performance*:** 120 packages/minute (with products of up to L150 mm and 1 kg). In MID conditions (M).

** Maximum performance will depend on the size, weight and morphology of the product, as well as on the regularity of the infeed of the products, the rejection system installed and MID conditions (M).*

CW-4200/400 (NO REJECTORS)

- 1 infeed and 1 weighing L400 x W280 mm conveyor.
- For products of up to L300 x W280 mm and up to 6 kg (in dynamic weighing). Up to L350 x W280 mm in static weighing.
- Without rejection system (check for options).
- **Performance***: 80 packages/minute (with products of up to L200 mm and 2 kg). In MID conditions (M).

** Maximum performance will depend on the size, weight and morphology of the product, as well as on the regularity of the infeed of the products, the rejection system installed and MID conditions (M).*

CW-4200/600 (NO REJECTORS)

- 1 infeed and 1 weighing L600 x W400 mm conveyor.
- For products of up to L500 x W400 mm and up to 15 kg (in dynamic weighing). Up to L550 x W400 mm in static weighing.
- Without rejection system (check for options).
- **Performance***: 70 packages/minute (with products of up to L350 mm and 2 kg). In MID conditions (M).

** Maximum performance will depend on the size, weight and morphology of the product, as well as on the regularity of the infeed of the products, the rejection system installed and MID conditions (M).*

OPTIONS

OPTION	CHARACTERISTICS	REF.
Touch screen console	TFT 15".	Contact us

OPTION	CHARACTERISTICS	REF.
Rejection by 1 pneumatic piston (for model CW-4200/400)	<p>1 rejection L600 x W280 mm conveyor with 1 pneumatic piston.*</p> <p>For products of up to L200 x W280 m and up to 6 kg (in dynamic weighing).</p> <p>Performance**: 80 packages/minute (with products of up to L200 mm and 2 kg). In MID conditions (M).</p> <p>For models CW-4200/350 and CW-4200/600, contact us.</p> <p><i>* All the rejection systems (pneumatic piston, "Air-jet®", etc.) depend on the type of product/packaging, required speed, collection system, etc.; please always check with Dibal.</i></p> <p><i>** Maximum performance will depend on the size, weight and morphology of the product, as well as on the regularity of the infeed of the products, the rejection system installed and MID conditions (M).</i></p>	Contact us
Rejection by 2 pneumatic pistons (for model CW-4200/400)	<p>1 rejection L1,000 x W280 mm conveyor with 2 pneumatic pistons.*</p> <p>For products of up to L200 x W280 mm and up to 6 kg (in dynamic weighing).</p> <p>Performance**: 80 packages/minute (with products of up to L200 mm and 2 kg). In MID conditions (M).</p> <p>For models CW-4200/350 and CW-4200/600, contact us.</p> <p><i>* All the rejection systems (pneumatic piston, "Air-jet®", etc.) depend on the type of product/packaging, required speed, collection system, etc.; please always check with Dibal.</i></p> <p><i>** Maximum performance will depend on the size, weight and morphology of the product, as well as on the regularity of the infeed of the products, the rejection system installed and MID conditions (M).</i></p>	Contact us
Other rejection systems (by "Air-jet®", rotating blade or folding conveyor)	<p>Depending on the type of product/packaging, required speed, collection system, etc., a rejection system other than the piston type may be required.</p>	Contact us
L350 x W200 mm separation conveyor	<p>For model CW-4200/350.</p>	Contact us

OPTION	CHARACTERISTICS	REF.
L400 x W280 mm separation conveyor	For model CW-4200/400.	Contact us
L600 x W280 mm conveyor (to replace L400 x W280 mm conveyor)	For model CW-4200/400.	Contact us
L800 x W280 mm conveyor (to replace L400 x W280 mm conveyor)	For model CW-4200/400.	Contact us
L800 x W280 mm weighing conveyor, 4 load cells, not MiD (to replace L400 x W280 mm conveyor)	For model CW-4200/400.	Contact us
L600 x W400 mm separation conveyor	For model CW-4200/600.	Contact us
L400 x W400 mm conveyor (to replace L600 x W400 mm conveyor)	For model CW-4200/600.	Contact us
L800 x W400 mm conveyor (to replace L600 x W400 mm conveyor)	For model CW-4200/600.	Contact us
L800 x W400 mm weighing conveyor, 4 load cells, not MID (to replace L600 x W400 mm conveyor)	For model CW-4200/600.	Contact us
Split belt	For transparent packs or irregular shape/cylindrical products.	Contact us
Vertical detector on arch	For transparent packs or irregular shape products. Infeed conveyor with split belt necessary.	Contact us
Container for rejects	Consult us.	Contact us

OPTION	CHARACTERISTICS	REF.
Right to left operation	Standard operation: from left to right.	Contact us
IP65 protection kit	Protected engines, bearings with lock, packaging gland, special load cell and heated detector.	Contact us
DIS software	Equipment configuration and production data. (See section on software).	Contact us
RMS Software	Equipment configuration, production data management and back up (LBS). (See section on software).	7340R1U3 / 7340RNU3
DCS Software	Production data management. (See section on software).	7340C0U3 / 7340CNU3
Wi-Fi	Wireless communications.	Contact us
Packed in phytosanitary wood case	Necessary depending on the destination.	PEEC080F
Metrological verification (M)	According to EU weighing directives (MID).	Contact us

ACCESSORIES



MOTORISED CONVEYOR

Infeed/output L1,000 x W280 mm conveyor, with smooth belt.



DIBAL VISION ARTIFICIAL VISION CAMARA

Contact us about applications.



BARCODE READERS

Contact us about applications.



ROLLERS CONVEYOR

Rollers conveyor for transporting or accumulating products.

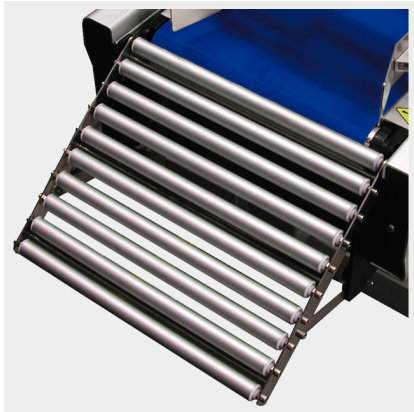

ROTATING TABLE

To collect wrapped and/or labelled products.

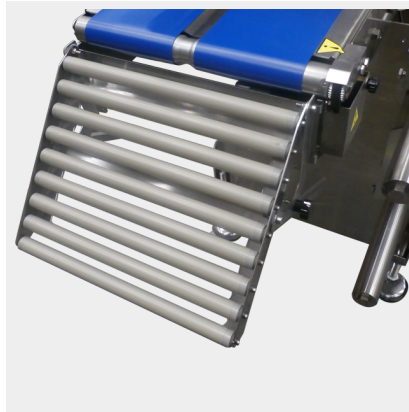

W200 MM EXIT RAMP

Non-motorised PVC rollers for W200 mm conveyors.



W280 MM EXIT RAMP

Non-motorised PVC rollers for W280 mm conveyors.



W400 MM EXIT RAMP

Non-motorised PVC rollers for W400 mm conveyors.



EXIT RAMP FOR REJECTED PRODUCTS

Ramp for rejection system.



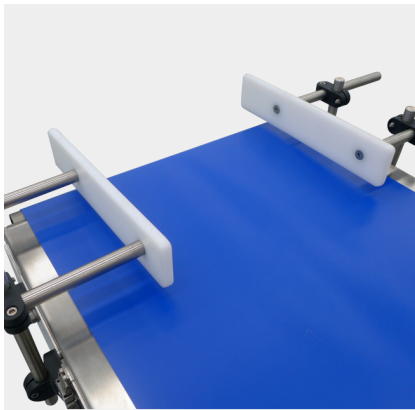

**PRODUCT GUIDING SYSTEM
IN INFEED CONVEYOR
(STANDARD)**

For special guides, contact us.



PRODUCT TURNING DEVICE

To change the position or orientation of the products.

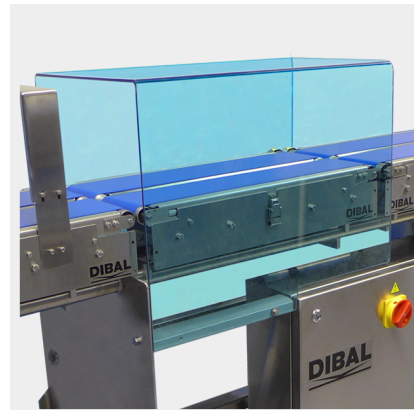

**POLYCARBONATE
PROTECTOR FOR
WEIGHING CONVEYOR**

To avoid external disturbances during the weighing process.



4 WHEELS WITH BRAKES

stud included.



**24V VISUAL AND AUDIBLE
ALARM**



Astintze, 26
48160 Derio (Vizcaya) Spain
T. (+34) 94 452 15 10
E. dibal@dibal.com