

**Kit Includes:** 50" LED Light Bar, Mounting Hardware, Deutsch DT Connector



## Features

- Advanced TIR (total internal reflection) optics
- High intensity 6000K Lumileds LEDs
- Slim design, for easy mounting
- Durable aluminum extrusion
- Pressure equalizing vent to eliminate condensation

## Specifications

- Input Voltage: 9-24VDC
- Input Power: 259 watts
- Current Draw: 18.5 amps @ 14V
- Operating Temperature: -40° to 185°F
- Weight: 8.2 lbs

## Wiring

Connect the red wire to positive supply, and black wire to negative or common ground.

**Please note:** This auxiliary lamp draws high current, and requires adequately-sized wiring for safe operation. If you are not using a Diode Dynamics wire harness, use wire sized 16 AWG or larger. If you are using a Diode Dynamics wire harness on a 24V system, you will need to replace the relay with a 24V relay. Please be mindful of current ratings and wire size, especially if splitting power signals to multiple light bars, or using switches. If you have any questions, please feel free to contact us for assistance.

## Mounting

If you wish, you may use the included hardware to mount your light bar. A number of fasteners are included, and can be used as you see fit. The most common mounting style is shown below. Stage Series Light Bars are also compatible with most standard mounting brackets on the market. Reference the dimensions on opposite side to determine the best mounting solution for your application.

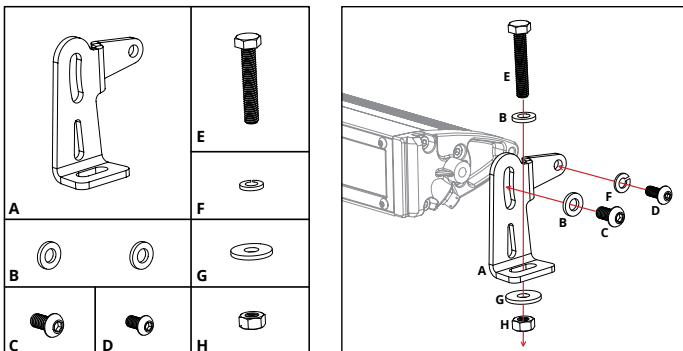

## Dimensions

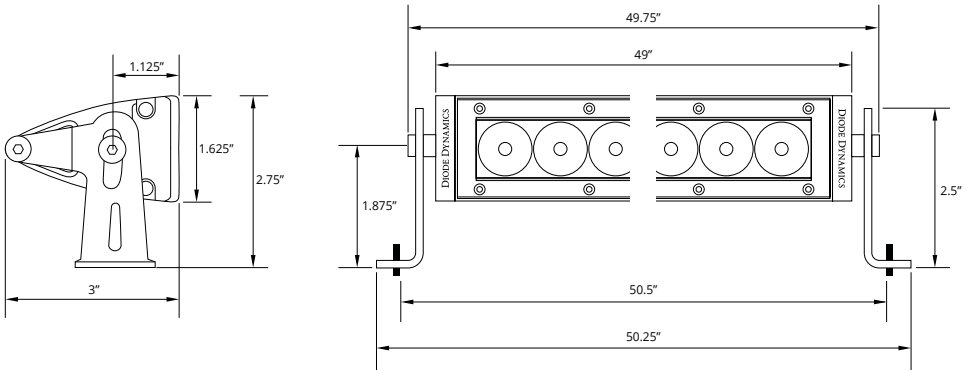

## Output

### Driving

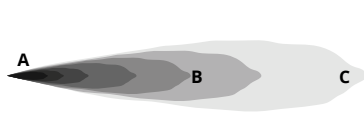

### Flood



### Combo

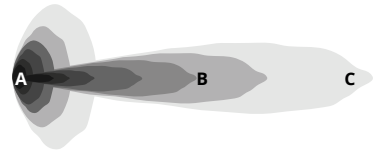

- A - lux at 10 meters
- B - Distance (m) with 1 lux
- C - Distance (m) with .25 lux

SS <sub>50</sub> 50" Light Bar		A	B	C		
Lens Color/Optics	cd*	Illuminance (lx)	Distance (m)		Measured Output	Output Color
White Driving	440,000	4,400	663	1,330	11,200 lumens	6000K White
White Flood	16,000	160	126	250	11,200 lumens	6000K White
White Combo	325,000	3,340	570	1,140	11,200 lumens	6000K White
Amber Driving	264,000	2,640	514	1,030	6,400 lumens	2000K Amber
Amber Flood	9,600	96	98	200	6,400 lumens	2000K Amber
Amber Combo	245,800	2,004	496	990	6,400 lumens	2000K Amber

\* PEAK BEAM INTENSITY

Please contact **Diode Dynamics** should you have any questions about the installation or wiring process, at **314-205-3033** (10a-5p CST) or **contact@diodedynamics.com**.

This installation guide is for the following SKU:

**DD5021** SS50 White Driving Light Bar  
**DD5035** SS50 White Combo Light Bar  
**DD6039** SS50 White Flood Light Bar

**DD5043** SS50 Amber Driving Light Bar  
**DD5057** SS50 Amber Combo Light Bar  
**DD6047** SS50 Amber Flood Light Bar

## Heavy Duty 2-Pin Wiring Harness

Thank you for your purchase of this Diode Dynamics Wiring Harness. Using standard Deutsch DT style connectors, this harness can be used with our Stage Series LEDs without backlight functionality, or for other power supply needs. Basic installation instructions are included below. Please contact us if you have any questions.

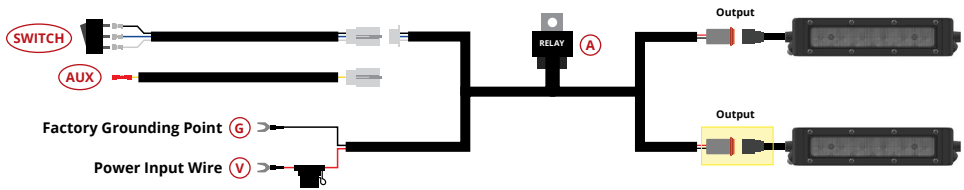

1. Determine a suitable location to mount the relay, (A) near the battery or main power terminal.
2. Connect the red power input wire (V) to the positive battery/power terminal. Connect the black ground wire to the negative battery terminal or a factory grounding point. (G)
3. **METHOD ONE - Add New Switch to Vehicle.** Determine a suitable location to mount the switch in the cabin of the vehicle. Route the switch wiring to that location. This may require going through the vehicle firewall. We recommend following the path of the factory wiring harness, and unplugging the switch while routing the wires. Drill a 3/4 inch hole and mount the switch. Reconnect wires to switch. (SWITCH)

**NOTE:** The gold spade on the switch should be connected to the black (ground) wire.

**METHOD TWO - Use OEM Upfitter/Auxiliary Switch.** An extra wire pigtail is included with this harness, which should be used if you plan to control your lights with a factory-installed "OEM" switch. At the white connector, unplug the switch wires from the harness, and connect the extra pigtail here instead. Using the butt connector at the end of the pigtail, crimp the yellow wire to an OEM Auxiliary Switch wire lead. (AUX)

**NOTE:** Power will be drawn from the battery, so any OEM Auxiliary Switch wires can be used, regardless of amperage rating.

4. Route the output wire(s) to each LED, avoiding any moving parts or direct contact with heat sources. Plug the output connector into the LED. If you have purchased the single-output harness, you will not have a second connector.
5. Test thoroughly, and aim the LED appropriately based on use. Please check your local laws and regulations regarding aiming, installation, and restrictions for on-road use, as applicable.

**This installation guide is for the following SKUs:**

**DD4031** Offroad Harness Single Heavy Duty

**DD4045** Offroad Harness Dual Heavy Duty