

2

1

B

B

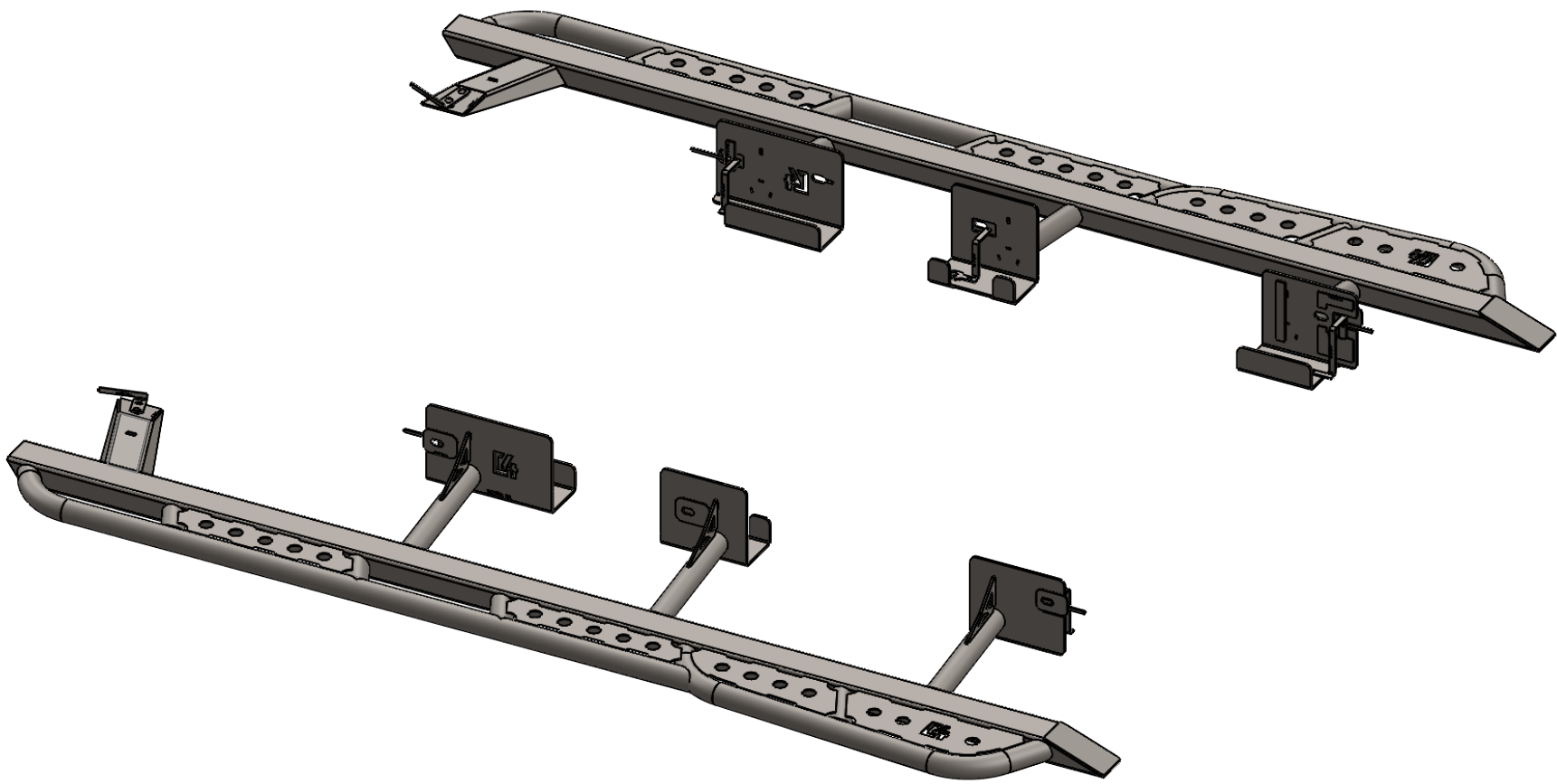

A

A



PROPRIETARY AND CONFIDENTIAL
 THE INFORMATION CONTAINED IN THIS DRAWING IS THE SOLE PROPERTY OF C4 FABRICATION, LLC. ANY REPRODUCTION IN PART OR AS A WHOLE WITHOUT THE WRITTEN PERMISSION OF C4 FABRICATION, LLC IS PROHIBITED.

MATERIAL

	NAME	DATE
DRAWN	RRC	8/24/22
CHECKED		
ENG APPR.		
MFG APPR.		
Q.A.		
COMMENTS:		

C4 FABRICATION

TITLE:
**22+ TUNDRA SLIDER
 INSTALL INSTRUCTIONS**

SIZE A	DWG. NO.	REV
------------------	----------	-----

DO NOT SCALE DRAWING

SHEET 1 OF 10

2

1

2

1

B

B

D1-

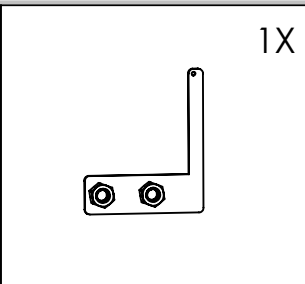

P1-

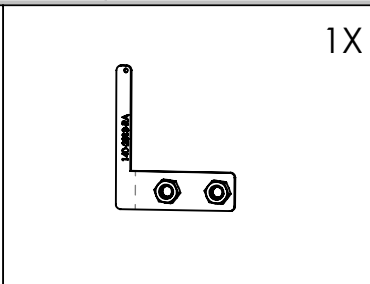

P5-

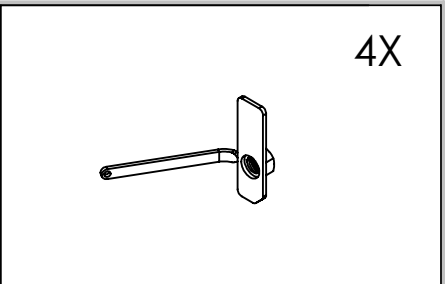

D2-

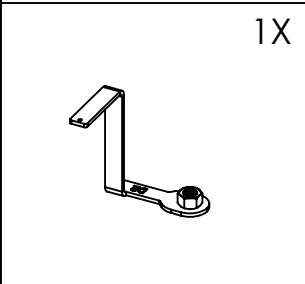

P2-

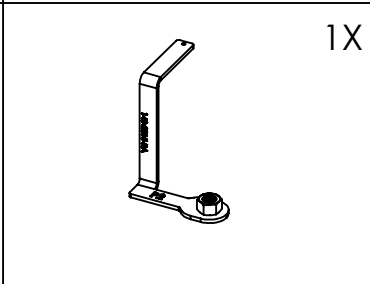

WP-

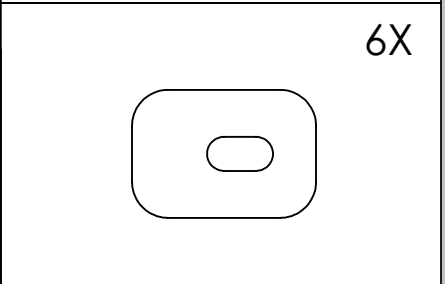

D3-

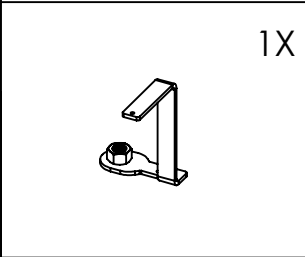

P3-

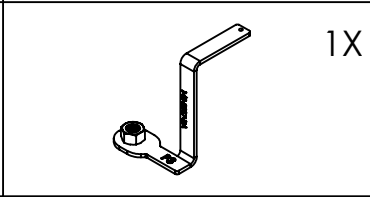

D4-

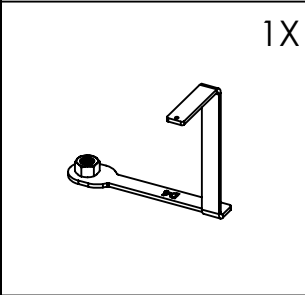

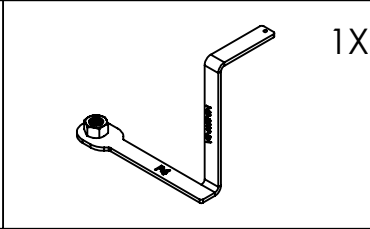

P4-



A

A

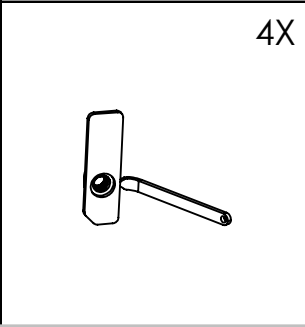
D5-

PROPRIETARY AND CONFIDENTIAL
 THE INFORMATION CONTAINED IN THIS DRAWING IS THE SOLE PROPERTY OF C4 FABRICATION, LLC. ANY REPRODUCTION IN PART OR AS A WHOLE WITHOUT THE WRITTEN PERMISSION OF C4 FABRICATION, LLC IS PROHIBITED.

MATERIAL

	NAME	DATE
DRAWN	RRC	8/24/22
CHECKED		
ENG APPR.		
MFG APPR.		
Q.A.		
COMMENTS:		

C4 FABRICATION

TITLE:
**22+ TUNDRA SLIDER
 INSTALL INSTRUCTIONS**

SIZE A	DWG. NO.	REV
------------------	----------	-----

DO NOT SCALE DRAWING SHEET 2 OF 10

2

1

2

1

B

B

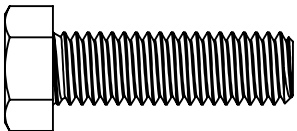
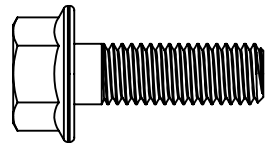
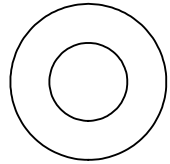
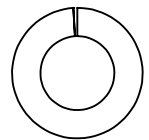
ITEM	IMAGE	QTY
GR8 3/8" x 1.25"		16x
M8 x 25		1
GR8 3/8" FLAT WASHER		17x
GR8 3/8" LOCK WASHER		16x

A

A

G



PROPRIETARY AND CONFIDENTIAL
 THE INFORMATION CONTAINED IN THIS DRAWING IS THE SOLE PROPERTY OF C4 FABRICATION, LLC. ANY REPRODUCTION IN PART OR AS A WHOLE WITHOUT THE WRITTEN PERMISSION OF C4 FABRICATION, LLC IS PROHIBITED.

MATERIAL

	NAME	DATE
DRAWN	RRC	8/24/22
CHECKED		
ENG APPR.		
MFG APPR.		
Q.A.		

COMMENTS:

C4 FABRICATION

TITLE:
**22+ TUNDRA SLIDER
 INSTALL INSTRUCTIONS**

SIZE A	DWG. NO.	REV
------------------	----------	-----

2

1

2

1

B

B

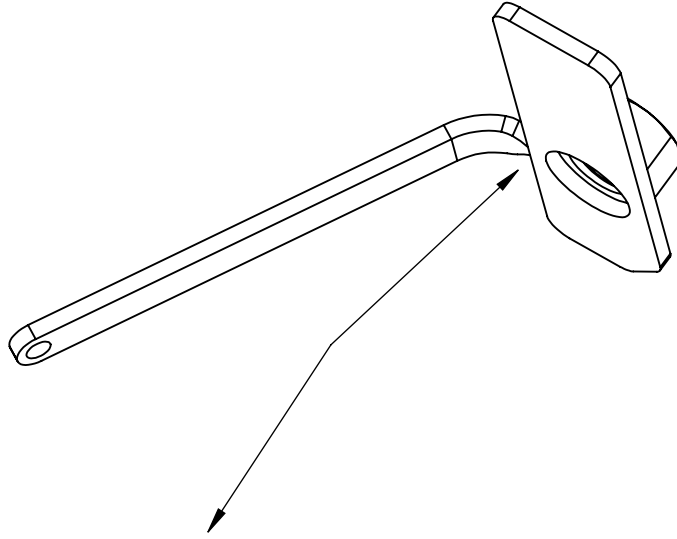

BEND PART "P5" TO ROUGHLY 70 DEGREES WITH PLYERS/WRENCH

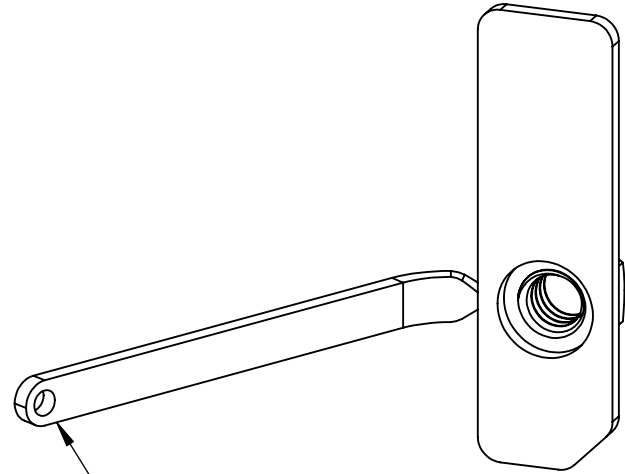

OPTIONAL: RUN STRING THROUGH HOLE TO PREVENT PIECE BEING DROPPED INTO FRAME

NOTE: INCLUDES ONE EXTRA

A

A



PROPRIETARY AND CONFIDENTIAL
 THE INFORMATION CONTAINED IN THIS DRAWING IS THE SOLE PROPERTY OF C4 FABRICATION, LLC. ANY REPRODUCTION IN PART OR AS A WHOLE WITHOUT THE WRITTEN PERMISSION OF C4 FABRICATION, LLC IS PROHIBITED.

MATERIAL

	NAME	DATE
DRAWN	RRC	8/24/22
CHECKED		
ENG APPR.		
MFG APPR.		
Q.A.		
COMMENTS:		

C4 FABRICATION

TITLE:
**22+ TUNDRA SLIDER
 INSTALL INSTRUCTIONS**

SIZE	DWG. NO.	REV
A		

2

1

2

1

B

B

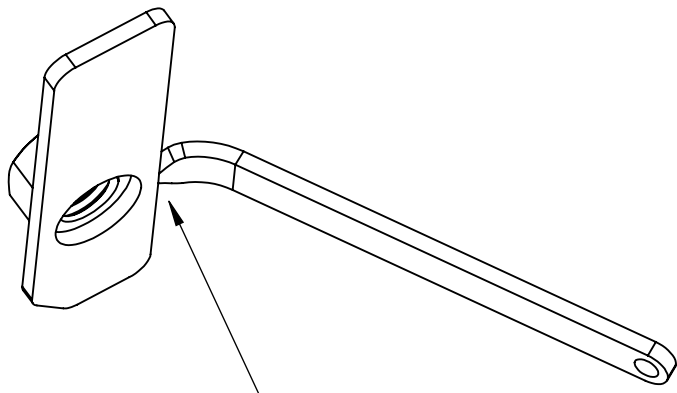

BEND PART "D5" ROUGHLY 70DEGREES WITH PLYERS/WRENCH

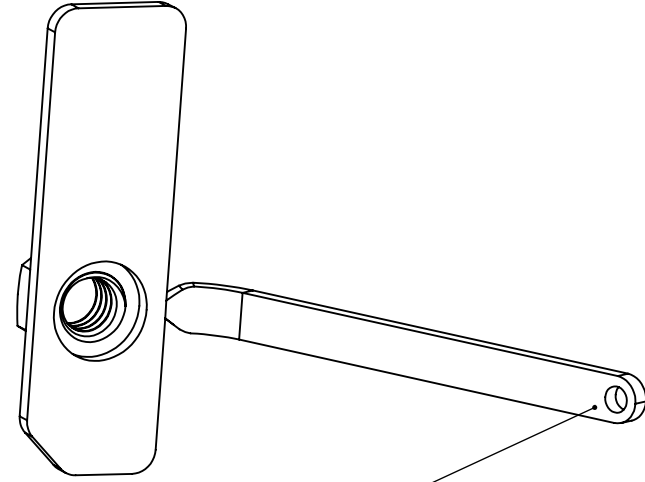

OPTIONAL: RUN STRING THROUGH HOLE TO PREVENT PIECE BEING DROPPED INTO FRAME

A

A

NOTE: INCLUDES ONE EXTRA



PROPRIETARY AND CONFIDENTIAL
 THE INFORMATION CONTAINED IN THIS DRAWING IS THE SOLE PROPERTY OF C4 FABRICATION, LLC. ANY REPRODUCTION IN PART OR AS A WHOLE WITHOUT THE WRITTEN PERMISSION OF C4 FABRICATION, LLC IS PROHIBITED.

MATERIAL

	NAME	DATE
DRAWN	RRC	8/24/22
CHECKED		
ENG APPR.		
MFG APPR.		
Q.A.		
COMMENTS:		

C4 FABRICATION

TITLE:
**22+ TUNDRA SLIDER
 INSTALL INSTRUCTIONS**

SIZE	DWG. NO.	REV
A		

2

1

2

1

B

B

A

A

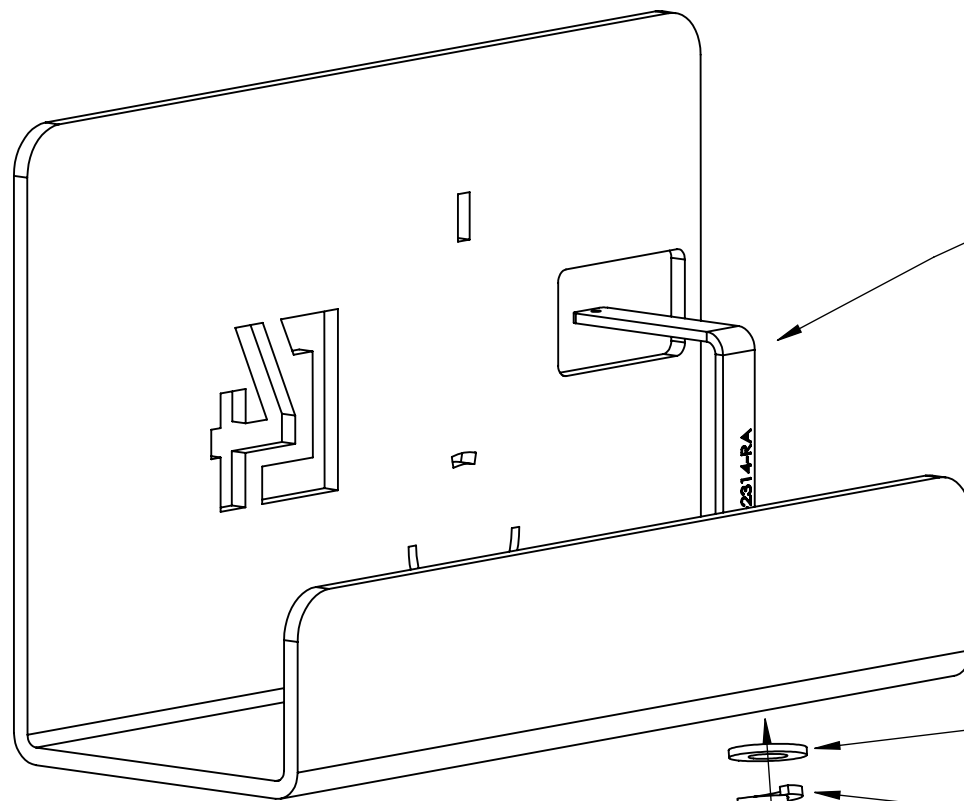

PLACE NUT STICK AS SHOWN:
MAKE SURE THE HOLES LINE UP TO
ALLOW BOLT TO THREAD

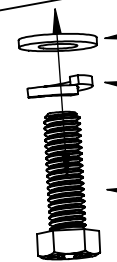

GR8 3/8" FLAT WASHER

GR8 3/8" LOCK WASHER

GR8 3/8" x 1.25" BOLT



PROPRIETARY AND CONFIDENTIAL
THE INFORMATION CONTAINED IN
THIS DRAWING IS THE SOLE
PROPERTY OF C4 FABRICATION,
LLC. ANY REPRODUCTION IN PART
OR AS A WHOLE WITHOUT THE
WRITTEN PERMISSION OF C4
FABRICATION, LLC IS PROHIBITED.

MATERIAL

	NAME	DATE
DRAWN	RRC	8/24/22
CHECKED		
ENG APPR.		
MFG APPR.		
Q.A.		
COMMENTS:		

C4 FABRICATION

TITLE:
**22+ TUNDRA SLIDER
INSTALL INSTRUCTIONS**

SIZE	DWG. NO.	REV
A		

DO NOT SCALE DRAWING

SHEET 6 OF 10

2

1

2

1

NOW PLACE "P5 OR D5" DEPENDING ON WHAT SIDE YOU ARE ON, THROUGH THE SLOT OF THE FRAME MOUNT AND SUPPLIED PLATE AS SHOWN IN THESE IMAGES

B

B

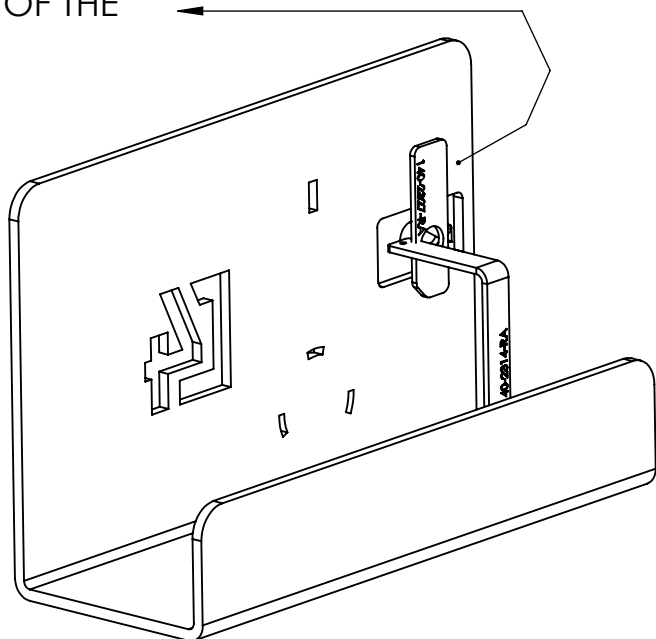
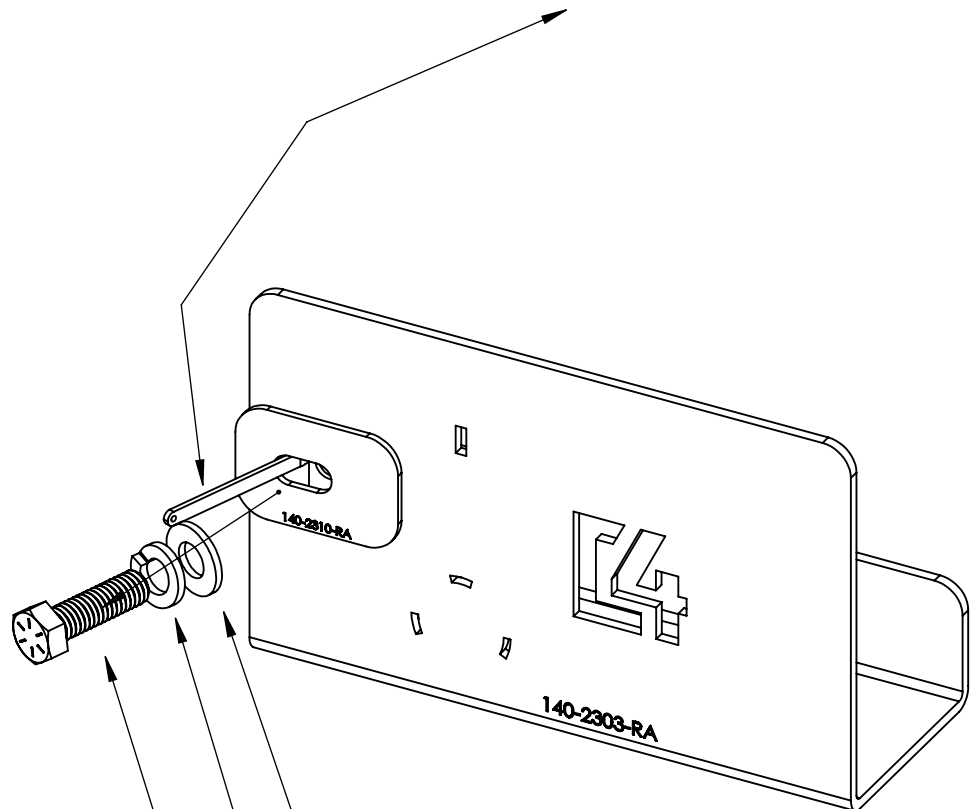

GR8 3/8" FLAT WASHER

GR8 3/8" LOCK WASHER

GR8 3/8" x 1.25" BOLT

A

A



PROPRIETARY AND CONFIDENTIAL
 THE INFORMATION CONTAINED IN THIS DRAWING IS THE SOLE PROPERTY OF C4 FABRICATION, LLC. ANY REPRODUCTION IN PART OR AS A WHOLE WITHOUT THE WRITTEN PERMISSION OF C4 FABRICATION, LLC IS PROHIBITED.

MATERIAL

	NAME	DATE
DRAWN	RRC	8/24/22
CHECKED		
ENG APPR.		
MFG APPR.		
Q.A.		
COMMENTS:		

C4 FABRICATION

TITLE:
**22+ TUNDRA SLIDER
 INSTALL INSTRUCTIONS**

SIZE	DWG. NO.	REV
A		

DO NOT SCALE DRAWING

SHEET 7 OF 10

2

1

2

1

B

B

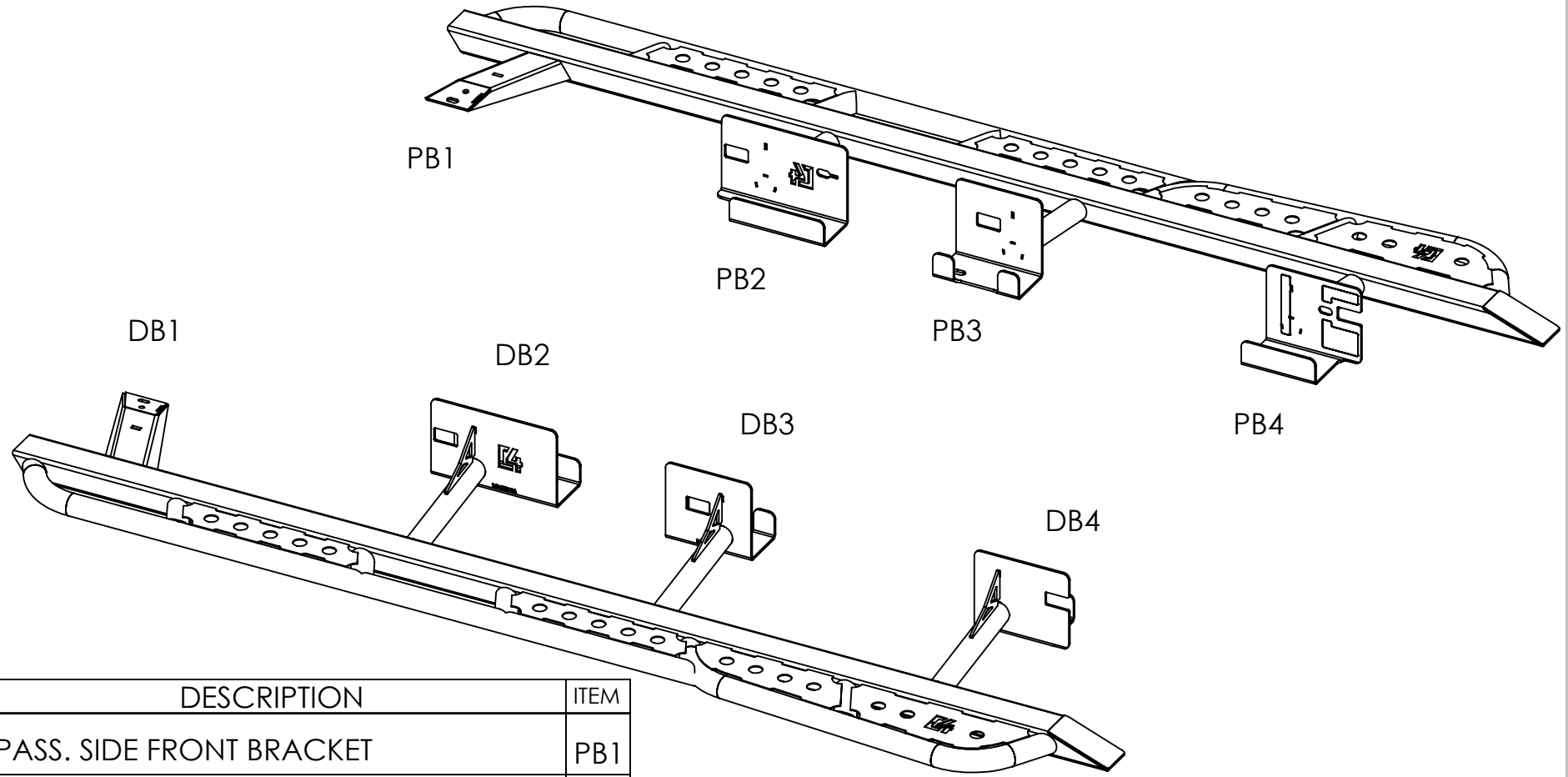

A

A

DESCRIPTION	ITEM
PASS. SIDE FRONT BRACKET	PB1
PASS. FRONT MIDDLE FRAME BRACKETS	PB2
PASS. REAR MIDDLE FRAME BRACKETS	PB3
PASS. REAR FRAME BRACKET	PB4
DRIVER FRONT FRAME BRACKET	DB1
DRIVER FRONT MIDDLE FRAME BRACKET	DB2
DRIVER REAR MIDDLE FRAME BRACKET	DB3
DRIVER REAR FRAME BRACKET	DB4

C4 FABRICATION

PROPRIETARY AND CONFIDENTIAL
 THE INFORMATION CONTAINED IN THIS DRAWING IS THE SOLE PROPERTY OF C4 FABRICATION, LLC. ANY REPRODUCTION IN PART OR AS A WHOLE WITHOUT THE WRITTEN PERMISSION OF C4 FABRICATION, LLC IS PROHIBITED.

MATERIAL

	NAME	DATE
DRAWN	RRC	8/24/22
CHECKED		
ENG APPR.		
MFG APPR.		
Q.A.		
COMMENTS:		

C4 FABRICATION

TITLE:
**22+ TUNDRA SLIDER
 INSTALL INSTRUCTIONS**

SIZE A	DWG. NO.	REV
------------------	----------	-----

DO NOT SCALE DRAWING SHEET 8 OF 10

2

1

2

1

A

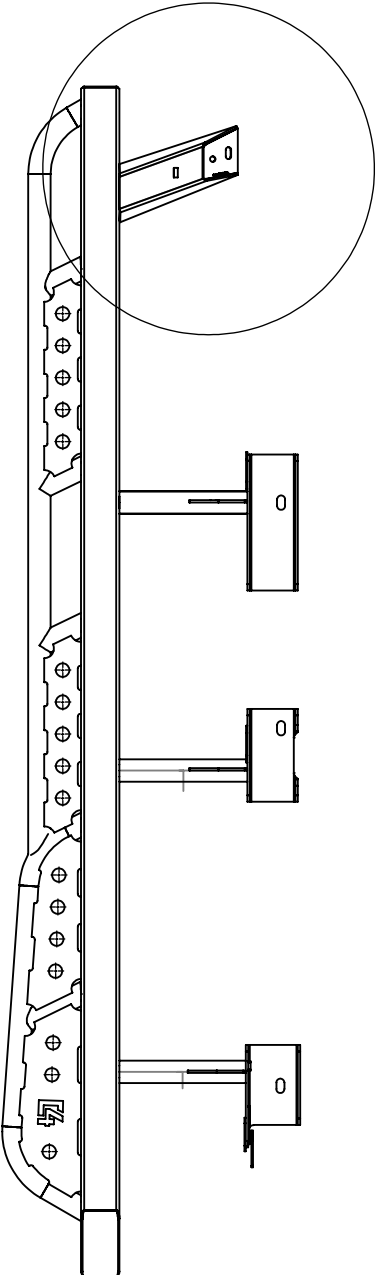

THIS HOLE IS OPTIONAL TO DRILL OUT

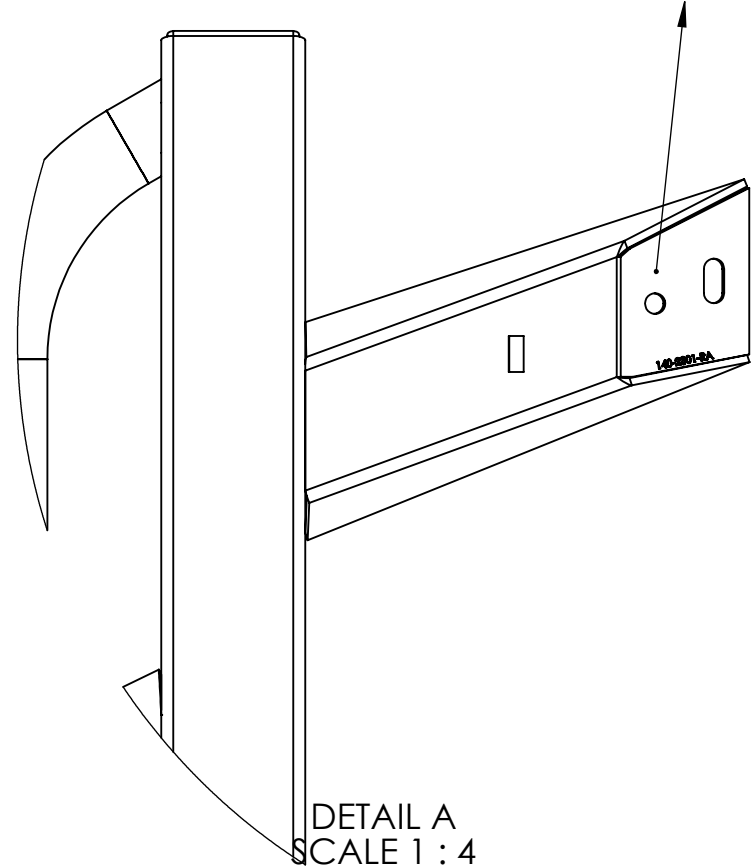

B

B

A

A



PROPRIETARY AND CONFIDENTIAL
 THE INFORMATION CONTAINED IN THIS DRAWING IS THE SOLE PROPERTY OF C4 FABRICATION, LLC. ANY REPRODUCTION IN PART OR AS A WHOLE WITHOUT THE WRITTEN PERMISSION OF C4 FABRICATION, LLC IS PROHIBITED.

MATERIAL

	NAME	DATE
DRAWN	RRC	8/24/22
CHECKED		
ENG APPR.		
MFG APPR.		
Q.A.		
COMMENTS:		

C4 FABRICATION

TITLE:
**22+ TUNDRA SLIDER
 INSTALL INSTRUCTIONS**

SIZE	DWG. NO.	REV
A		

2

1

1. SLIDE NUTSTICKS D2/D3/D4 INTO THE CORRESPONDING SLOTS OF THE FRAME. D2 CORRESPONDS TO THE FRAME PLATE LABELED DB2 ON PAGE 8 AND THE REST FOLLWOING. WHILE USING TWO JACK STANDS, HOLD UP THE SLIDER THAT CORRESPONDS TO THE DRIVERS SIDE OF THE TRUCK. MAKE SURE THE FRAME PLATES OF THE SLIDER ARE NEAR THE RECTANGLE SLOTS ON THE FRAME(EXCLUDING THE FRONT SUPPORTS).

2. REMOVE PLASTIC SLOT COVERS USING FLAT HEAD SCREWDRIVER. ALSO REMOVE GROUND + WIRE HARNESS BRACKET ON PASSENGER SIDE.

3. USING YOUR PROVIDED BOLTS/LOCK WASHERS/FLAT WASHERS. WHILE HOLDING THE SLIDER INTO POSITION, LOOSELY THREAD THE PROVIDED HARDWARE THROUGH THE BOTTOM OF THE SLIDER, THROUGH THE FRAME AND INTO THE NUTSTICK, AS SEEN ON PAGE 6. DO NOT TIGHTEN THE BOLTS, THIS WILL ALLOW MOVEMENT FOR EASE OF INSTALLATION. WITH THE THREE BOLTS THREADED LOOSELY, THE SLIDER WILL BE ABLE TO HOLD ITS OWN WEIGHT.

4. NOW USING THE NUTSTICKS D5 AND P5. THESE WILL ALLOW YOU TO THREAD BOLTS ONTO THE SIDE OFYOUR SLIDERS. FOR FRAME BRACKET DB2,DB3,AND PB4 YOU WILL NEED TO USE A P5 NUTSTICK. FOR FRAME BRACKETS PB2, PB3 AND DB4 YOU WILL NEED NUTSTICK D5. SLIDE IT THROUGH THE SLIDER FRAME AND THROUGH THE FRAME. WHILE HOLDING IT THERE, SLIDE ON A WASHER PLATE(WP) SHOWN IN PAGE

5. THEN THREAD A BOLT WITH THE SUPPLIED LOCK AND FLAT WASHER THROUGH THE COMPONENTS AND LOOSELY TIGHTEN. DO THIS FOR ALL 6 REAR FRAME PLATES.

6. THE DRIVER AND PASSENGER FRONT SUPPORTS BOLT TO THE BODY MOUNT USING ONE FACTORY HOLE AND NUTSTICK. THE SECOND HOLE IS AN OPTIONAL DRILL HOLE SHOWN IN PAGE 9. NUT STICK IS PLACED THROUGH THE LARGE HOLE ON THE FRONT BODY MOUNT.

B

B

A

A

 <p>PROPRIETARY AND CONFIDENTIAL THE INFORMATION CONTAINED IN THIS DRAWING IS THE SOLE PROPERTY OF C4 FABRICATION, LLC. ANY REPRODUCTION IN PART OR AS A WHOLE WITHOUT THE WRITTEN PERMISSION OF C4 FABRICATION, LLC IS PROHIBITED.</p> <p>MATERIAL</p>		NAME	DATE	<h2 style="text-align: center;">C4 FABRICATION</h2>			
	DRAWN	RRC	8/24/22		TITLE:		
	CHECKED				<h1>22+ TUNDRA SLIDER INSTALL INSTRUCTIONS</h1>		
	ENG APPR.				SIZE	DWG. NO.	REV
	MFG APPR.				A		
	Q.A.						
COMMENTS:				DO NOT SCALE DRAWING		SHEET 10 OF 10	