



# THE BIG BEAR

I N S T A L L   I N S T R U C T I O N S

# HARDWARE CHECKLIST

Exact hardware color counts may vary based on the options selected at checkout.

**10**

3/16" Rivet



**28**

1/4"-20  
(1") SB



**8**

M8-1.25  
(16mm)



**8**

1/4"-20  
(9/16")



**6**

1/4"-20  
(1/2") SB



**14**

1/4" TNut



**42**

1/4" Flat  
Washer



**2**

FRONT  
BRACKETS

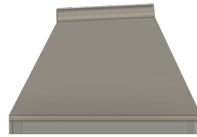

**2**

REAR  
BRACKETS



**2**

FLAT RIVET  
ATTACHMENTS



**2**

CONTOURED RIVET  
ATTACHMENTS

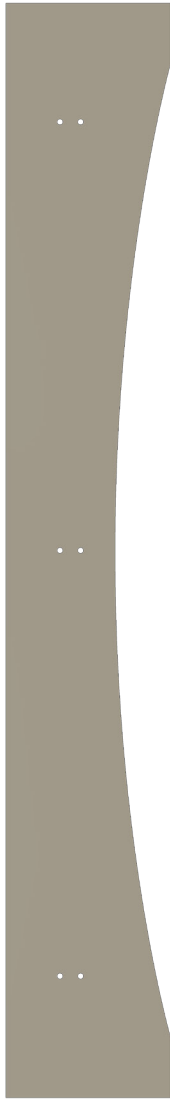
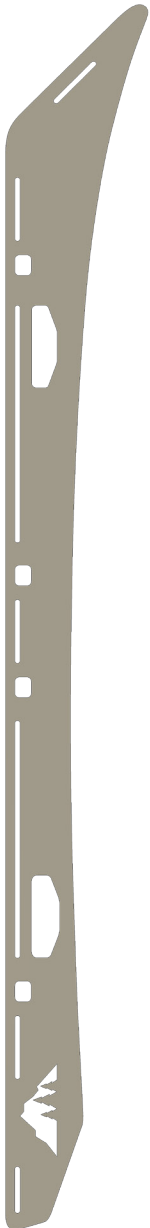

## BEFORE YOU BEGIN

This is considered an *expert level install*. If you are not confident about the drilling process we recommend seeking the help of a local install shop.

**TOOLS REQUIRED:** Drill, 3/16" Drill Bit, 3/16" Rivet Tool, 7/16" Wrench, 7/16" Socket, 5/32" Allen Key,  
**RECOMMENDED:** Drill Bit Stopcollar (set at 1")

## USING TNUTS

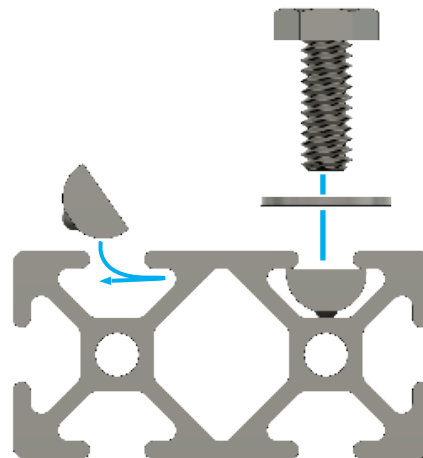

**FLAT**

**CONTOURED**



REAR



FRONT

## **IMPORTANT NOTES**

### **RIVET ATTACHMENTS**

There are two different types of rivet attachments in your hardware package. It is important that the contoured attachments go on the front of the vehicle and not the rear.

Double check that you have the right attachments before starting the rivet process.

### **OEM EDGE TRIM**

During the install you will need to remove the black factory edge trim from the roof gutter. We recommend reinstalling this after you rack is on.

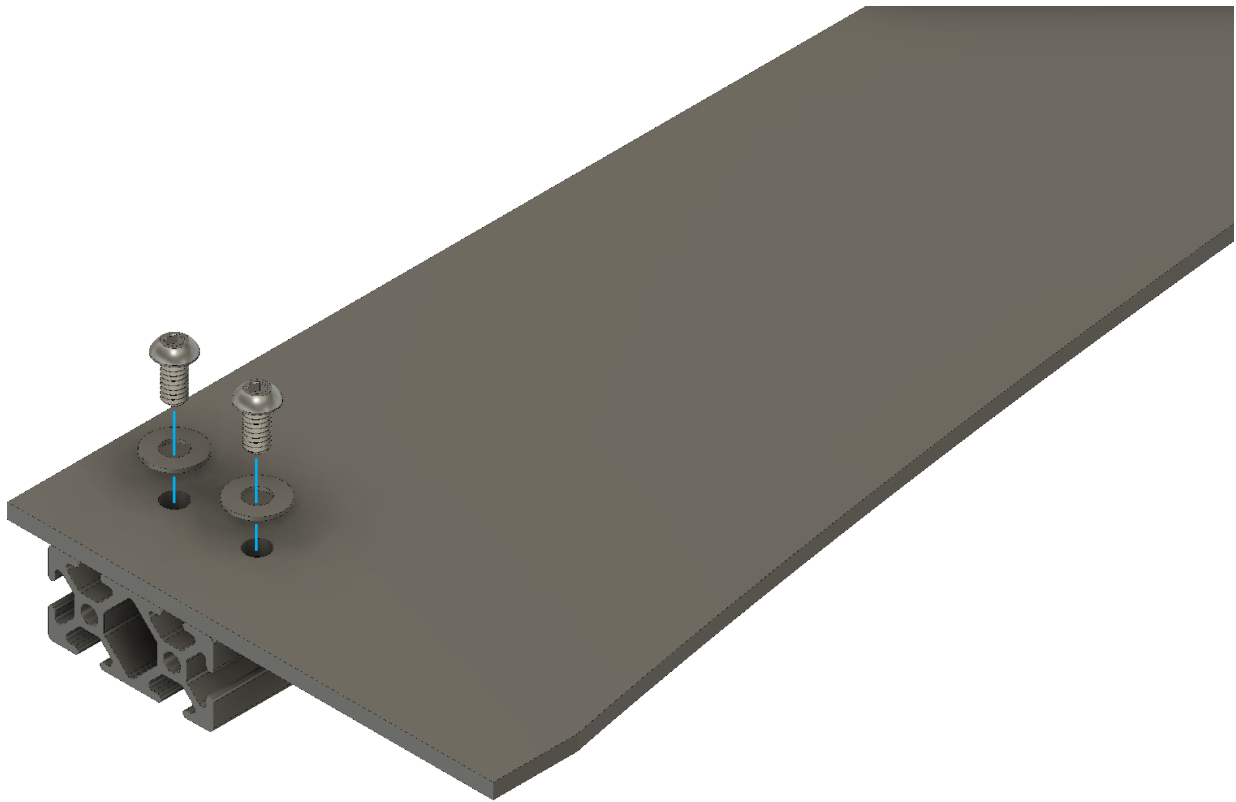

## PRE-ASSEMBLY

Required Components:

**6x** 1/4"-20 x 1/2"

**6x** 1/4" Flat Washers

**6x** Tnuts

Drop 6 tnuts into the slots on the cross member and line them up with the holes in the fairing. Secure with 6 bolts and washers.

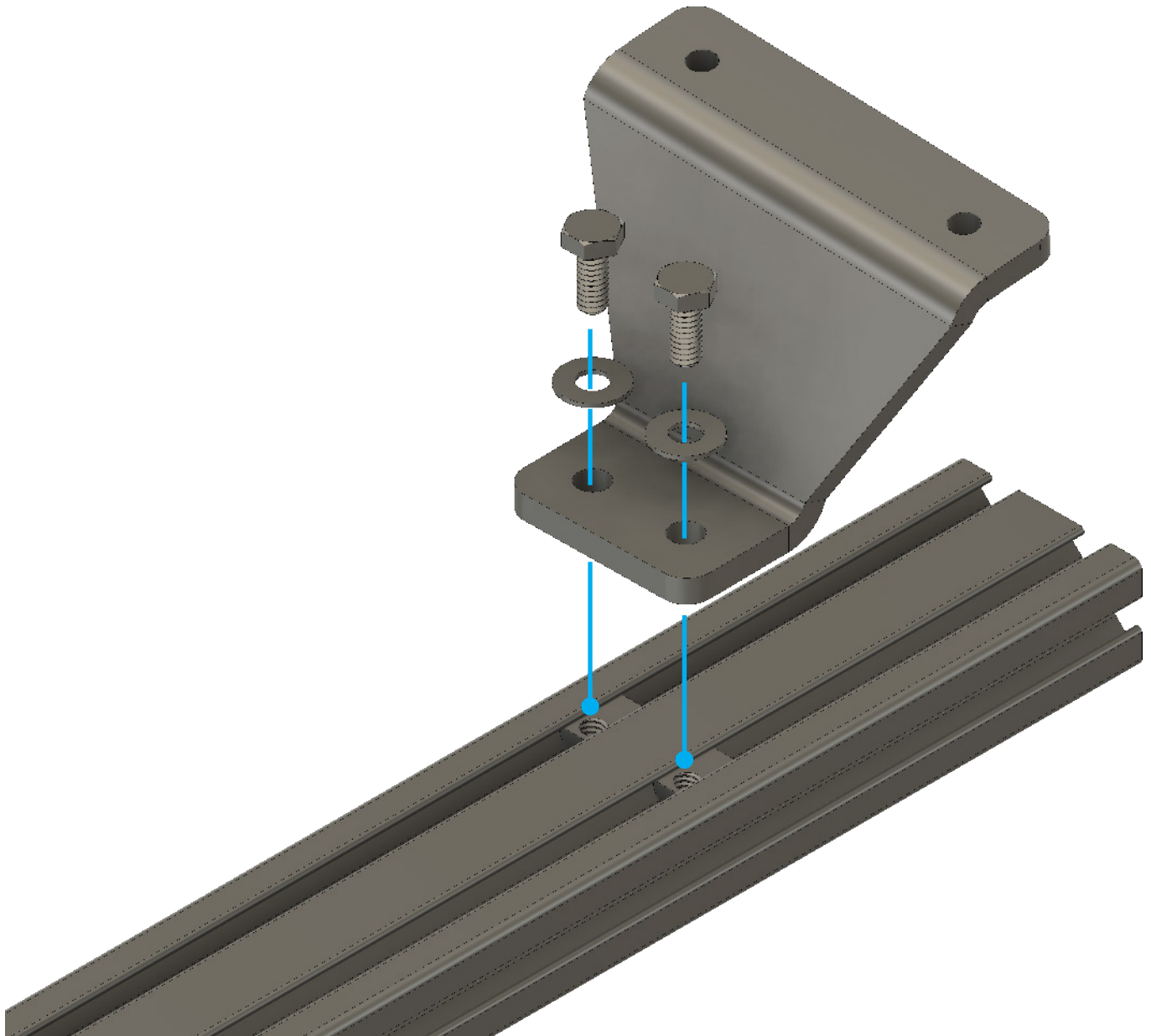

## PRE-ASSEMBLY

Required Components:

- 8x** 1/4"-20 x 9/16"
- 8x** 1/4" Flat Washers
- 8x** 1/4" Nuts

Secure top of the mounting brackets to the two main cross members.

Leave the hardware that attaches the mount to the crossbar loose. This will make it easier when centering the bars later.

## 01

Required Components:

**8x** 1/4"-20 x 1"

**8x** 1/4" Flat Washers

Secure the two main crossmembers with mounts to the sideplates of the rack. Position the crossbars in the center of the short slots on the side plates. You should see one slot in the front, and one in the rear, just in front of the mountain.

Align the small slots in the rack side with the ends of the main support crossmembers. Secure it using 8 bolts and washers. Leave the bolts loose enough to move the sideplate to the position that matches the curve of the vehicle.

Once the rack is positioned correctly, tighten down all of the hardware for the rack sides, mounting hardware and roof track bolts.

## 02

Required Components:

**4x** 1/4"-20 x 1"

**4x** 1/4" Flat Washers

Position the wind fairing in line with the diagonal slot at the front of the rack. Align the bottom of the fairing with the tip of the roof rack and secure it using 4 bolts and washers.



## 03

Required Components:

**12x** 1/4"-20 x 1"

**12x** 1/4" Flat Washers

Secure all of the remaining cross members to the rack system. Position according to your load requirements.

Position the assembled rack on the roof of your vehicle. Place the rivet attachments under the mounting brackets. You will mark your positions in the next steps. This assembled rack will serve as your drilling template.

**We recommend loosening the bolts and adjusting the rack to best match the curve of the vehicle in this stage.**

Use a tape measure and center all of the bars on the vehicle. We recommend measuring from the inside edge of the mount to the outside face of the crossbar.

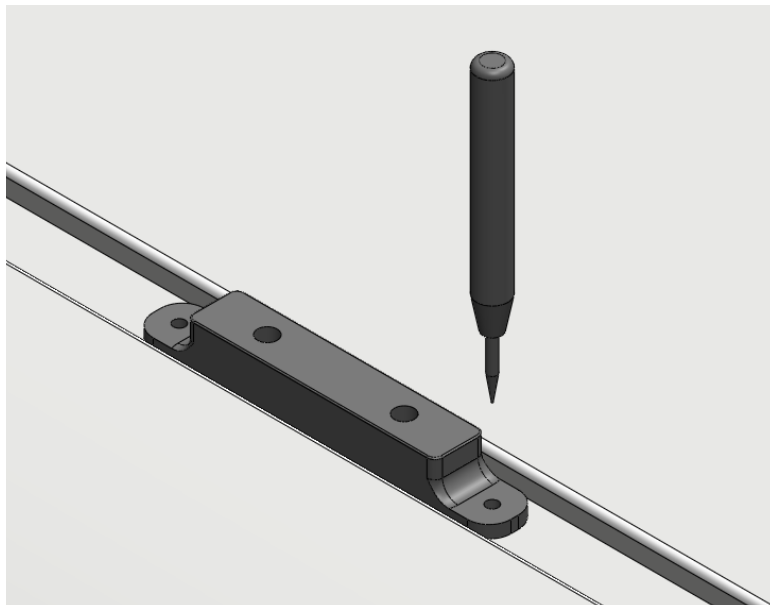

**THE NEXT STEPS ARE CRITICAL AND ARE CONSIDERED AN EXPERT LEVEL INSTALL. IF YOU ARE NOT COMFORTABLE DRILLING PLEASE FIND A LOCAL SHOP TO INSTALL YOUR RACK.**

## DRILLING

Required Tools:

**1x** Center Punch

**1x** 13/64" or #8 Drill Bit

With the rack on the truck, mark the position for each rivet spacer **USING A PUNCH** to create your starting points for drilling. This is important as the drill bit will want to walk away while drilling your pilot holes. The position of these holes are important in making sure that the rack fits your vehicle correctly. **Measure 3 times, check 4 times.** Be extremely careful not to drill through your airbags - using a drillstop on your drill bit can help prevent this by limiting the travel of the drill bit.

With the holes marked, the rack can be removed from the roof. It is worth double checking that the rack sits in its final configuration before marking, removing, and drilling. The rivet spacers can also be removed from the mounting brackets on the rack to assist the following steps.

Once you have your drilling points marked with the punch, drill the hole using a **13/64" or #8** sized drill bit. A pilot hole using a smaller drill bit - such as a 1/8" or 5/32" bit - can be drilled first. **DO NOT** allow the drill bit to plunge after the hole is drilled. The headliner is only a small distance below the surface of the roof. Be sure to keep the drill bit as straight as possible while drilling. **AGAIN, DO NOT** allow the drill bit to plunge after the hole is drilled.

Check that the rivets will pass through the rivet spacer and the drilled hole. A tight fit is preferred in order to solidify the connection between the vehicle and the rack.

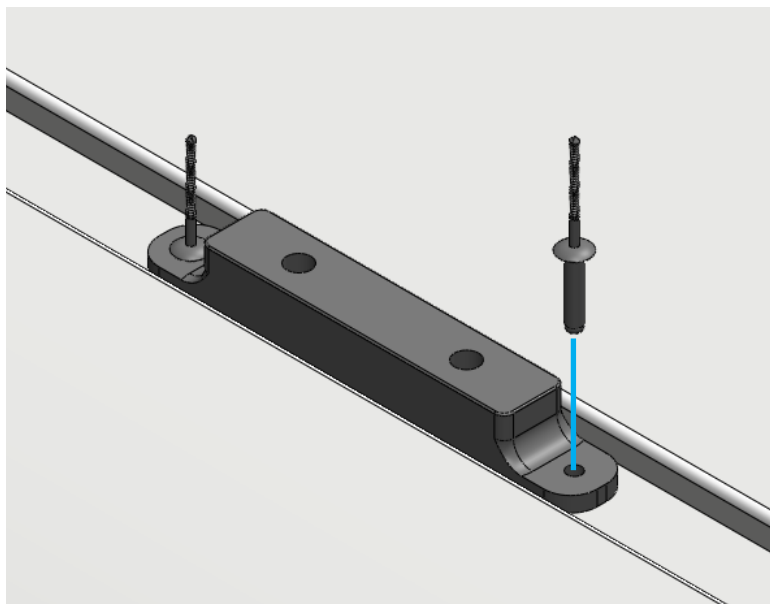
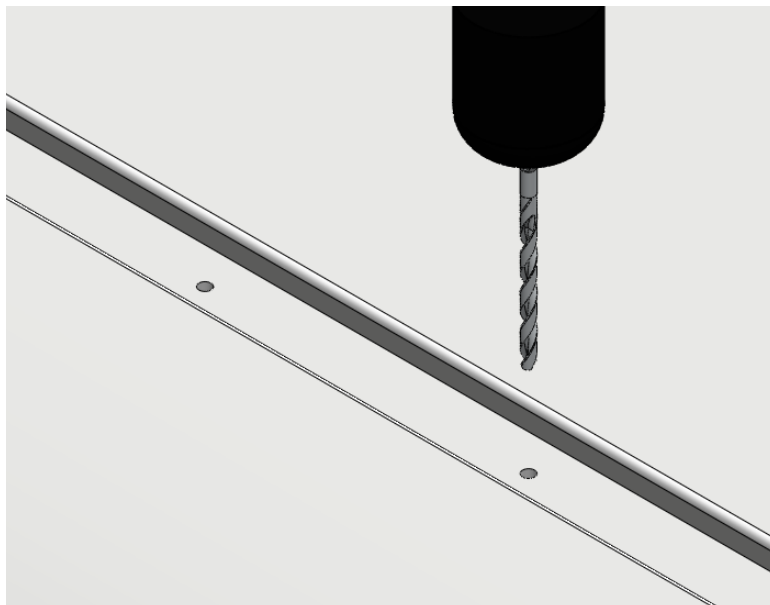



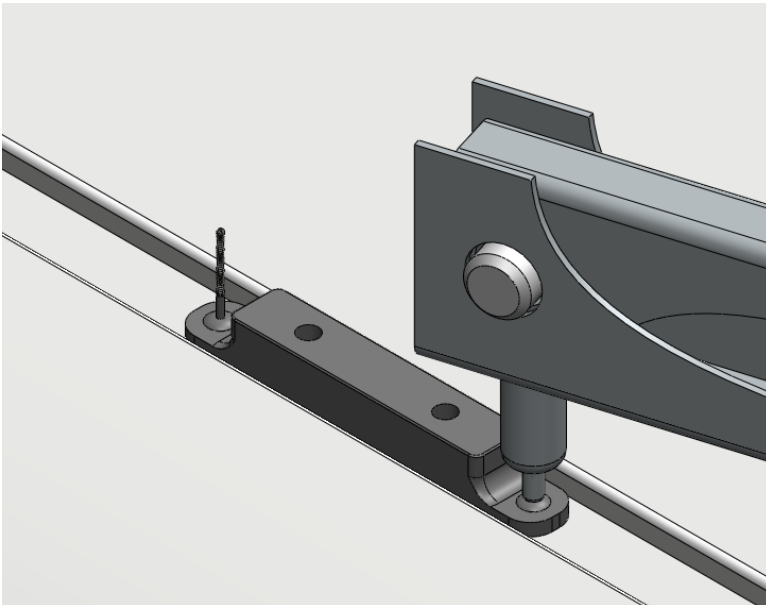

## RIVETS

Required Components:  
**8x 3/16" Rivets**  
**1x Rivet Tool**

Next, secure the rivet spacers using the holes you have drilled. It is important that the spacer is tight against the roof and free of debris before riveting it down. **Apply a small amount of silicone in and around the rivet spacer and rivet to seal up the hole in the roof.** Using your rivet tool, clamp down on the rivet as close to the head as possible. The mandrel of the rivet will shear off once it is installed and should be flush with the head.

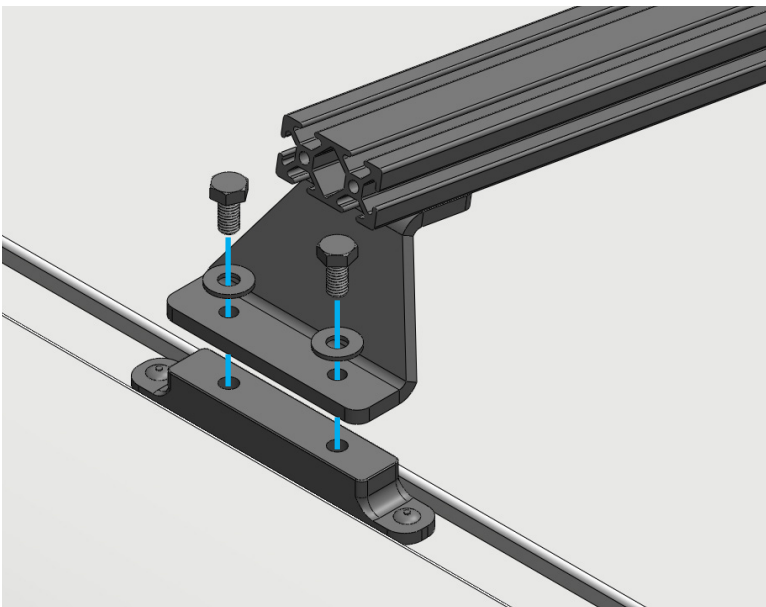

**WE RECOMMEND PLACING THE FULL RACK BACK ON THE ROOF FOR THE REMAINING STEPS. IMAGES ARE SHOWN WITHOUT SIDES FOR ILLUSTRATIVE PURPOSES.**

## MOUNTS

Required Components:  
**12x M8 Bolts**  
**12x M8 Flat Washers**

Next, re-install the assembled rack on the roof, allowing the mounting brackets to rest on the rivet feet. If these do not line up, loosen the hardware that secures the mounting bracket to the cross member and adjust as needed. Fasten the mounting bracket to the rivet spacer using the M8 x 16 hex bolt and washers with the addition of a drop of blue threadlocker on the bolt threads supplied with the rack.

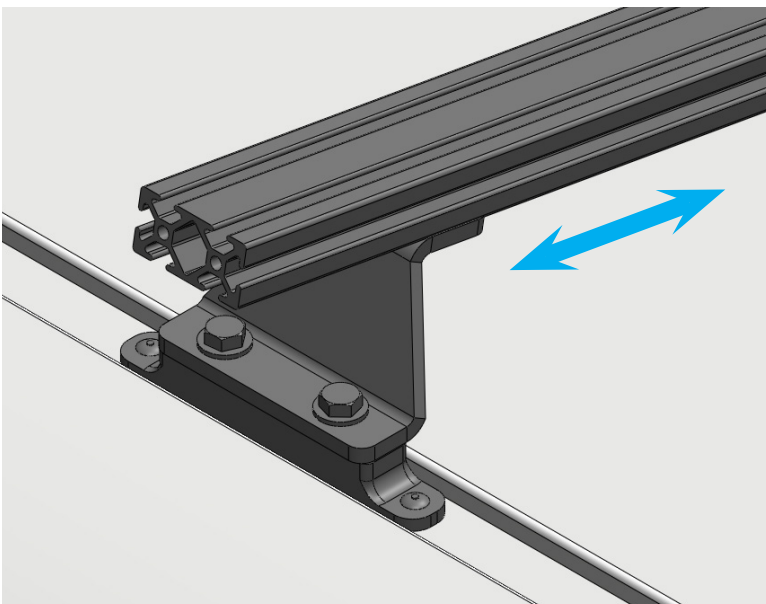



## FINAL ADJUSTMENTS

All fasteners should be tight at this point. If the rack needs to be adjusted forward or back visually, loosen the socket buttons securing the sideplates to the mount-crossmembers and slide as desired. Side-to-side adjustment can be achieved by loosening the 7/16" hex bolts that secure the mounting brackets to the crossmembers.

If no further adjustment is required, the installation is complete.

# EXPLORE.

All products built and designed by Sherpa Equipment Company are intended for off-road use and should be assembled, installed, and used according to Sherpa Equipment Company's recommendations. Sherpa Equipment Companies products should be used safely with good judgment towards others and surroundings.

By installing Sherpa Equipment Companies products on your vehicle you assume all liability. Sherpa Equipment Company will not be held liable for damages or loss associated with the installation or use of its products. It is recommended that you inspect your roof rack within the first 100 miles of installation and every 500 miles after.