



Installation Instruction for Pancake scale



Scale Components



platform (total: 2pcs)

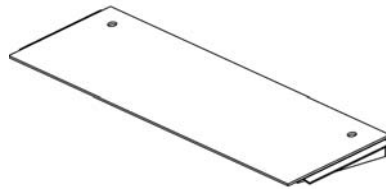

ramp A (total: 4pcs)

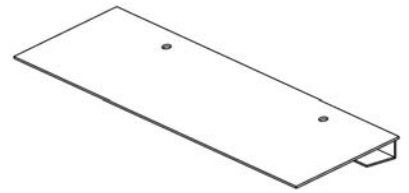

ramp B (total: 4pcs)

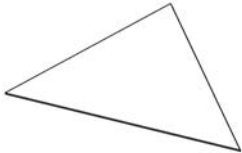

ramp C (total: 2pcs)



ramp D (total: 2pcs)

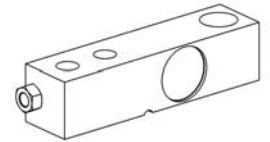

Load cell (total: 8pcs)



indicator (total: 8pcs)



indicator (total: 1pcs)



junction box (total: 2pcs)



Singal cable for indicator
(total: 2pcs)

Bolts details



M16 eyebolt
(4 pcs)



Stopper bolt
M10 x 60 mm
(18 pcs)



Anchor bolt
M12 x 100 mm
(16 pcs)



bolt for ramp
(16 pcs)

Tools Required for Installation



folklift



tape



churn drill



wrench



internal hexagonal wrench



chains (2 pcs)



hydraulic jack



flat blade screwdriver



hammer



Auto Socket Wrench



crowbar



spirit level

Scale Installation

(1) Make sure the complete installation is done on a level ground .

(2) Fix four eyebolts on the corners of platform .

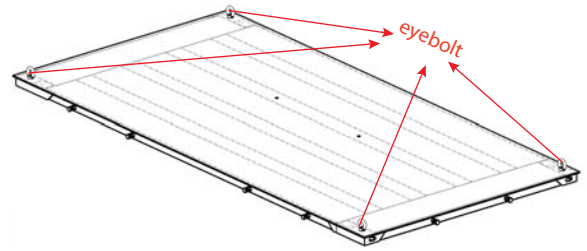

(3) Lift up platform by chains to install feet .

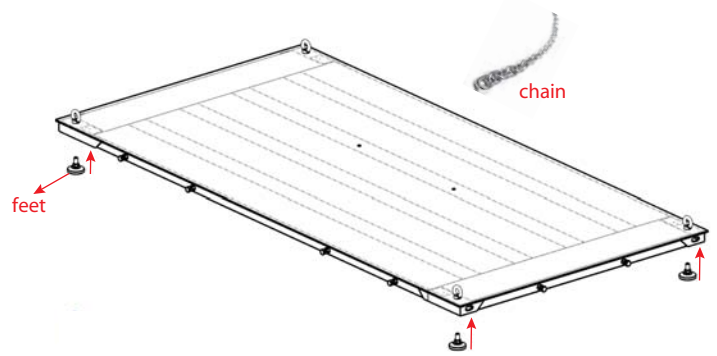

(4) Follow the same step to install the other piece .

Note : a. The hole on the corner of platform need to place on the lower left quarter and right corner .

b. Leave a space (3mm-5mm) between stopper bolt with U-beam on the other piece . to avoid impaction .

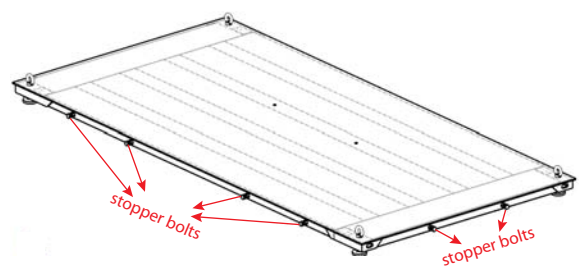
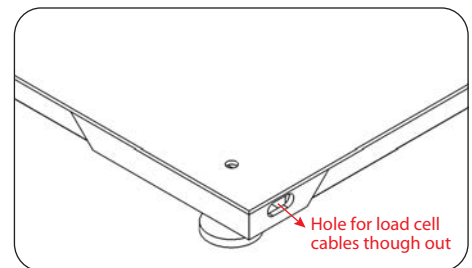
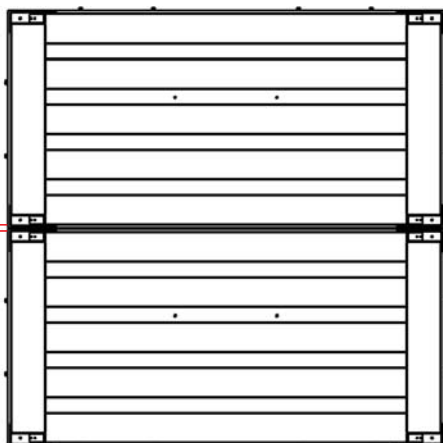
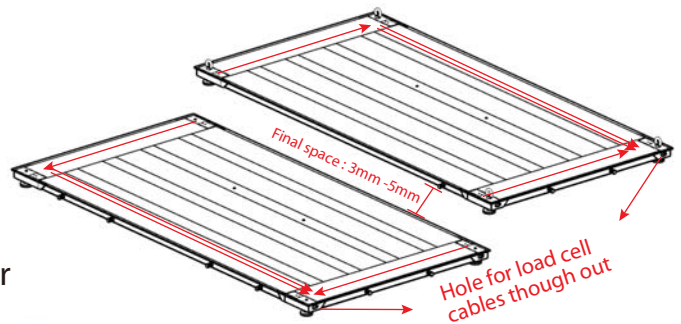

(5) Adjust eight feet height, make sure to keep two platforms on the same level .

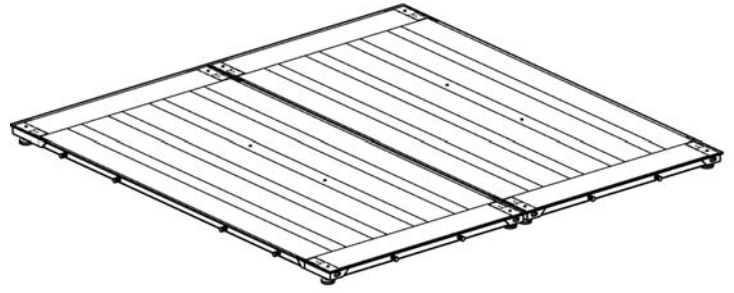

(6) Assembly ramps .

Note : Leave a space (3mm-5mm) between stopper bolt with ramps .

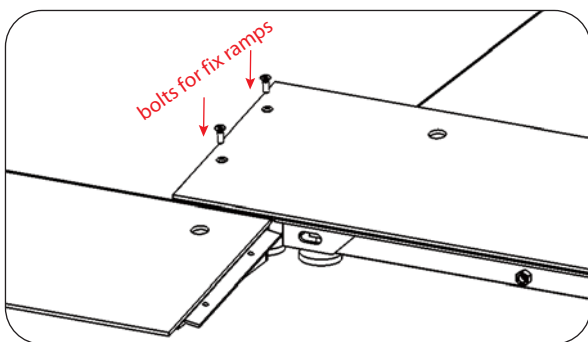
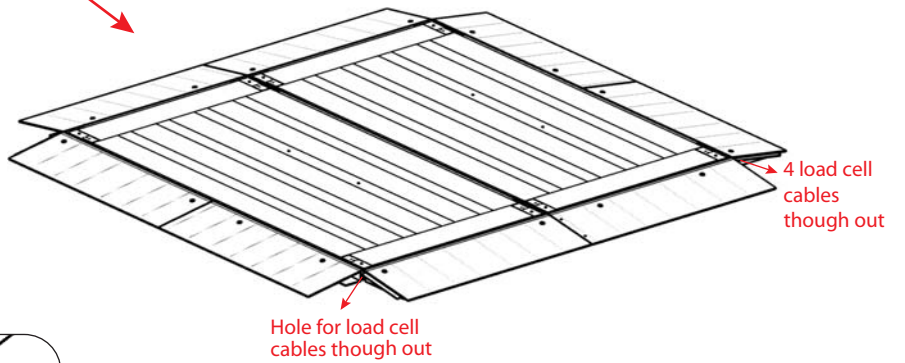
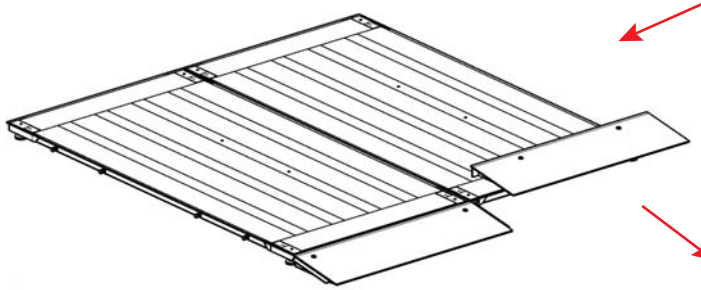
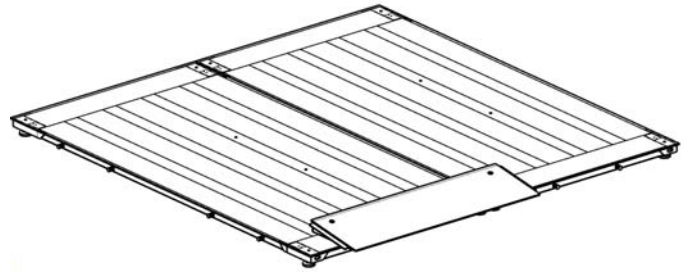

(7) Joint anchor bolts on ramps .

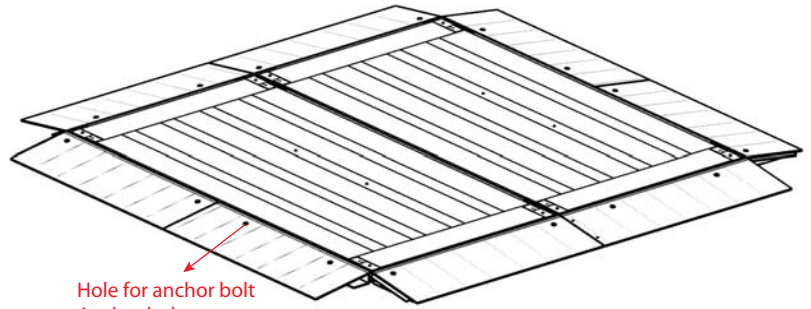

Hole for anchor bolt
 Anchor bolts
 Thread x length : M12 x 100 mm
 Qty: 16 pcs

(8) Place junction box under ramp , then joint four load cell cables to junction box .

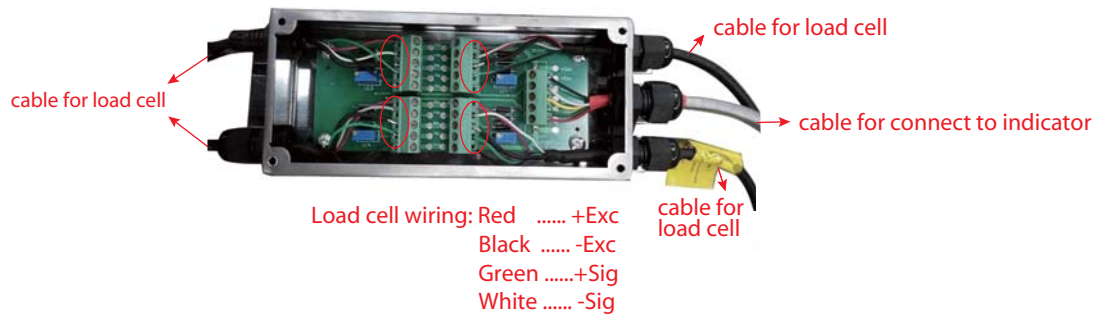
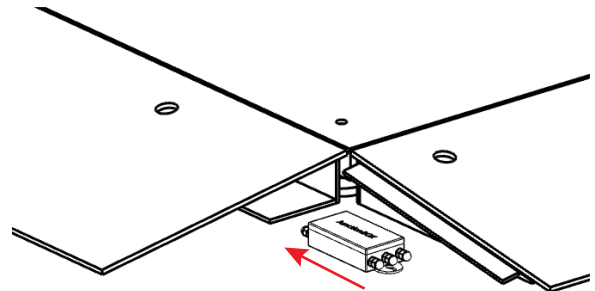

(9) Follow the same step to place the other junction box on the other side of ramp , then joint cables .

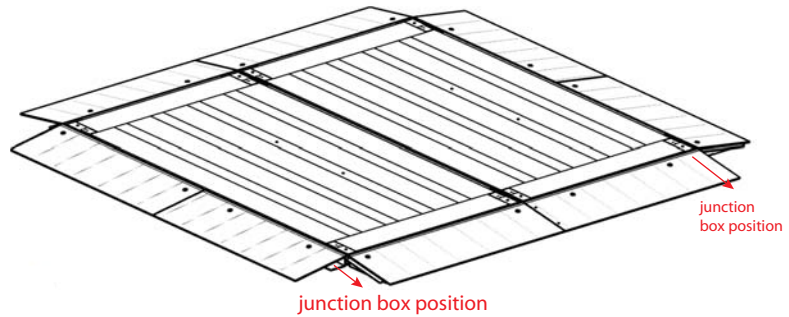

(10) Assembly four small ramps on four corners .

Note : Groove on small ramp is for cable though out .

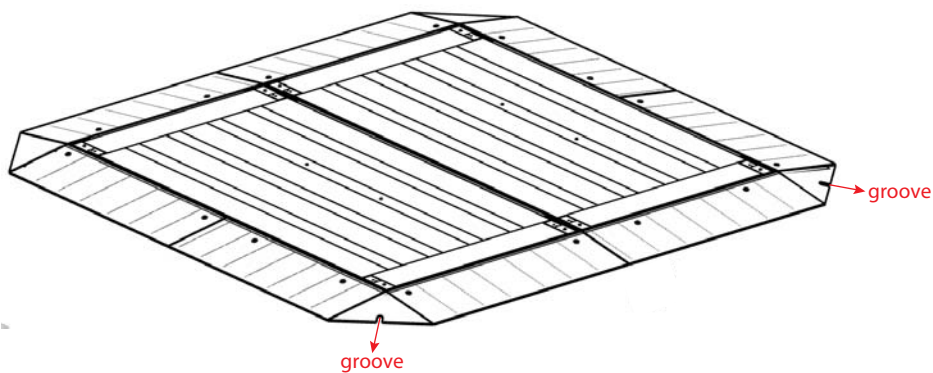
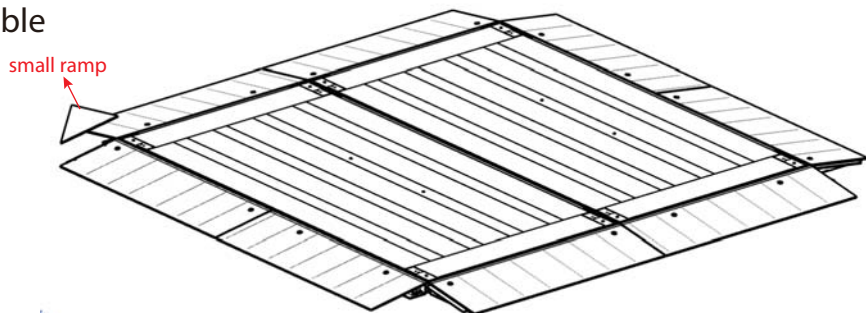

(11) Joint two signal cables to the indicator to complete installation .

