

# PS-IN202 Weighing Indicator



## User Manual

# Contents

## FRONT AND REAR VIEW OF THE INDICATOR

### CHAPTER 1 CONNECTIONS

- 1.1 WHAT'S IN THE BOX
- 1.2 CONNECTING TO THE WEIGH PLATFORM
- 1.3 CONNECTION TO A PRINTER OR COMPUTER
- 1.4 CONNECTION TO THE POWER SUPPLY

### CHAPTER 2 CONFIGURATION

- 2.1 SET UP ("P") MENU
- 2.2 Setup Menu Chart
- 2.3 Exiting the setup menu
- 2.4 USER ("S") MENU
- 2.5 User Menu Chart
- 2.6 Setup Menu Descriptions
- 2.7 User Menu Descriptions

### CHAPTER 3 CALIBRATION

- 3.1 Zero Calibration
- 3.2 Span Calibration
- 3.3 View calibration values
- 3.4 Key-in zero calibration value
- 3.5 Key-in span calibration value

### CHAPTER 4 OPERATION

- 4.1 Display
- 4.2 Display Details
- 4.3 Keyboard
- 4.4 Weighing
- 4.5 Tare Function

# Front and Rear View of the Indicator

FIG1 and FIG 2 show the front and rear view of the indicator.



**FIG 1.1**

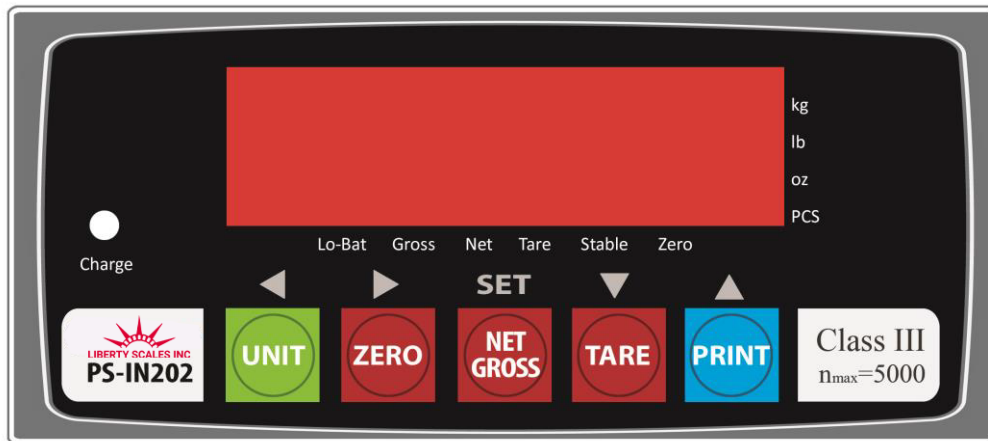

**FIG 1.2**

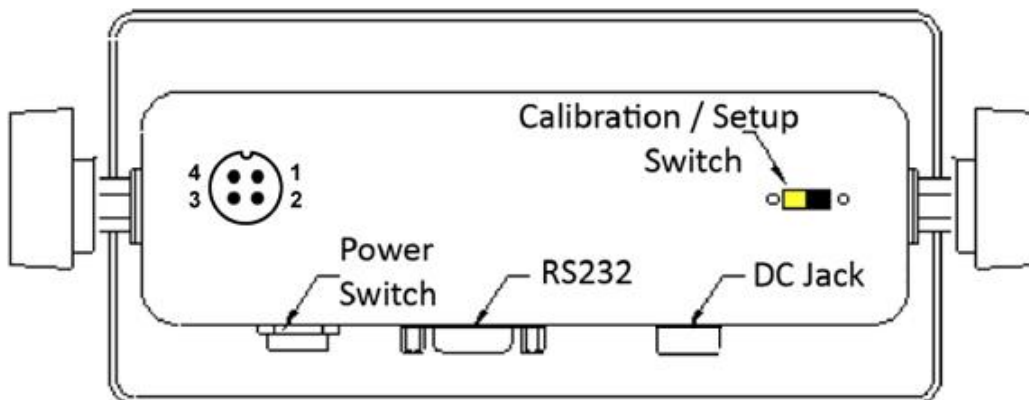

**FIG 2**

# Chapter 1

## Connections

### 1.1 WHAT'S IN THE BOX

The box contents are as follows:

- Indicator
- Power Adaptor
- Wall Mount Bracket
- 4 pin connector
- This Manual

### 1.2 CONNECTING TO THE WEIGH PLATFORM

a. Plug the 4-pin connector into the signal port on the rear panel of the indicator (for PS-IN202SS you need to mount the bare wires onto the board directly). Wire the bare wires and shield to the weigh platform's load cell(s) or junction box using the color codes shown below:

- RED: +Excitation
- BLACK: -Excitation
- GREEN: +Signal
- WHITE: -Signal

b. Alternatively, instead of using the shielded load cell cable supplied, a cable may be assembled with the pin assignments shown in FIG 3:

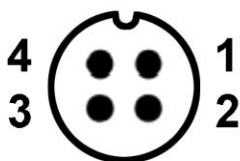

1	-	EXT +	Red Wire
2	-	SIG +	Green Wire
3	-	SIG -	White Wire
4	-	EXT -	Black Wire

FIG 3

### 1.3 CONNECTION TO A PRINTER OR COMPUTER

The indicator contains a standard full duplex RS-232 serial port, designed for connection to either a PC or a serial printer as shown in FIG 4.

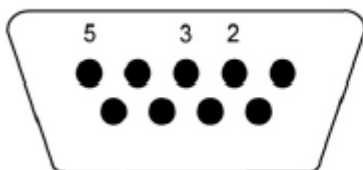

2	Receive Data
3	Transmit
5	Signal Ground RS-232

FIG 4

The indicator can be directly interfaced to a serial printer, remote display or computer communication cable (not included) using the D-SUB9 serial port connector.

This indicator is compatible with Prime Interface Software.

#### **1.4 CONNECTION TO THE POWER SUPPLY**

The indicator comes with an external AC adapter. Connect the AC adapter to the indicator then plug the main plug into a standard wall outlet. When plugged in, the built-in battery is being recharged. The “recharge” light will be on. We strongly recommend recharging the indicator for at least 12 hours before the first-time use.

## Chapter 2 Configuration

The indicator contains two main setup menus:

The Setup (“P”) menu

This configures the indicator to the weigh platform

The User (“S”) menu

This configures the serial communication port and enables some user options.

The Setup and User menus consist of several menu selections, each with its own sub-menu.

To set up the indicator, first select the appropriate menu mode. Keys **[UNIT]**, **[ZERO]**, **[TARE]** and **[PRINT]** become direction navigators (as indicated by the arrows above them) to move around the menus and the **[NET/GROSS]** key is used to save or SET the selections.

### 2.1 SET UP (“P”) MENU

- a. Switch off the indicator.
- b. On the rear panel, move the Calibration/Setup Switch to the “Setup” position. Left is calibration mode, right is weighing mode.
- c. Switch on the indicator. The indicator will display “P 1” to indicate that it is in Setup P menu mode.

Use the direction keys to navigate around in the Setup Menu Chart.

- a. To move to a new “P” heading, use the **[TARE]** (down) or **[PRINT]** (up) key to navigate the Setup Menu Chart.
- b. To move to the selection level, press the **[ZERO]** (right) key once. The current saved selection is shown.
- c. To view the available selections for the current “P” heading, use the **[TARE]** (left) or **[PRINT]** (up) key to navigate through the selection field.
- d. To save a new selection, press the **[NET/GROSS]** (Set) key. To exit without saving, press the **[UNITS]** (left) key to return to the current “P” heading.
- e. Repeat Steps 1 through 4 until the Setup Menu is programmed.

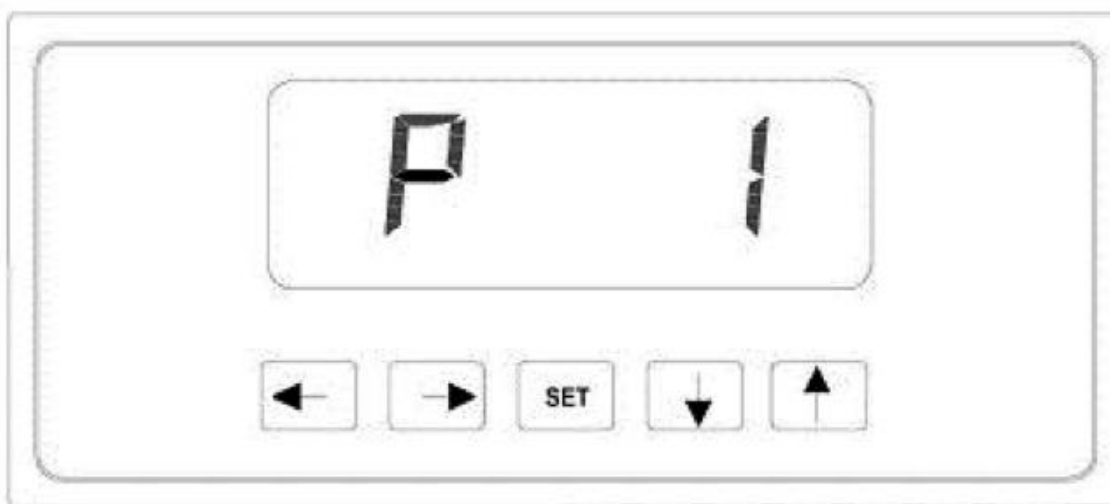

**FIG 5**

**2.2 Setup Menu Chart**

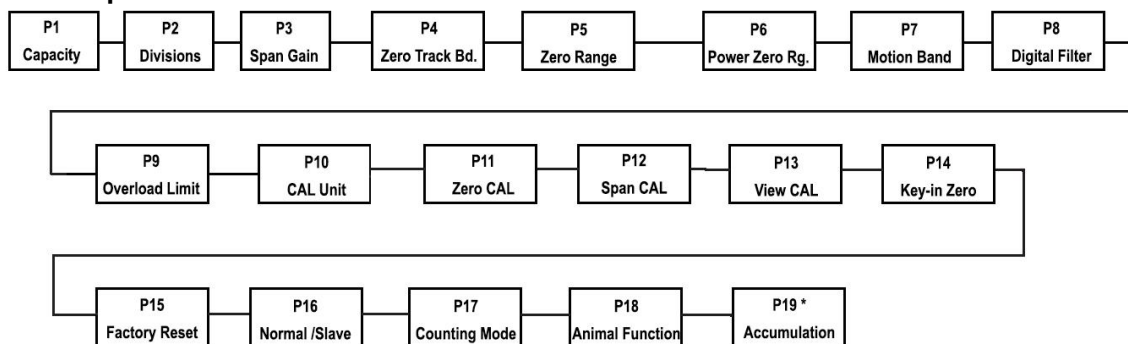

**FIG 6**

The User (“S”) sub-menus appear when scrolling left or right from the “P” menu. Some selections shown are not available on some versions.

**2.3 Exiting the setup menu**

- a. Switch off the indicator.
- b. On the rear panel, move the Calibration/Setup Switch to the “Calibration” position. Left is calibration mode, right is weighing mode.
- c. Switch on the indicator. The display will go through a digit check then go into Normal Operating mode. All front panel keys will now return to their normal mode of operation.

**2.4 USER (“S”) MENU**

- a. Enter the Setup (“P”) menu.
- b. Use the right or left direction keys to navigate the Setup (“P”) menu until the indicator shows “S 1”. Use the direction keys to navigate the User Menu Chart.

- c. To move to a new “S” heading, use the **[TARE]** (down) or **[PRINT]** (up) key to navigate the User Menu Chart.
- d. To move to the selection level, press the **[ZERO]** (right) key once. The current saved selection is shown.
- e. To view the available selections for the current “S” heading, use the **[TARE]** (down) or **[PRINT]** (up) key to navigate the selection field.
- f. To save a new selection, press the **[NET/GROSS]** (Set) key .To exit without saving, press the **[UNITS]** (left) key to return to the current “S” heading.
- g. Repeat Steps 2 through 5 until the Communication Menu is programmed.

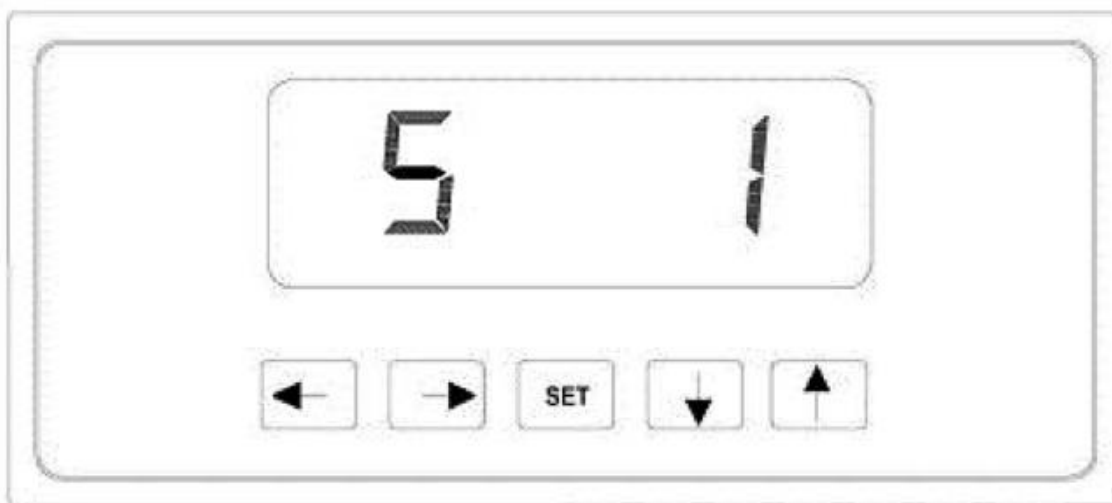

**FIG 7**

**2.5 User Menu Chart**

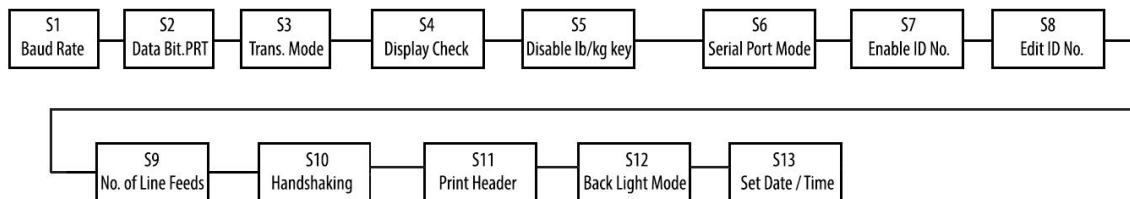

**FIG 8**

**2.6 Setup Menu Descriptions**

This section provides a more detailed description of the selections found in the Setup Menu Chart. Factory-set defaults are shown in bold with a checkmark (✓).



NAME/CODE	DESCRIPTION	CODE/VALUE
P1 Capacity	Full capacity of the scale. Value should be consistent with legal requirements and environmental limits on the useful system resolution.	<b>6.0000</b> √
P2 Accuracy	Accuracy of the scale. Value should be consistent with legal requirements and environmental limits on the useful system resolution.	Dynamic
P3 Span	Span Gain is related to the A/D integration time. The larger the span, the higher the internal resolution, but the slower the update speed. Note that the scale must be recalibrated whenever this parameter is altered. See Appendix C for more information.	<b>10</b> √ 80
P4 Zero Track Band	Selects the range within which the scale will automatically zero. Note that the scale must be in standstill to automatically zero. Selections are in Display Divisions.	0d <b>0.5d</b> √ 1d, 3d, 5d
P5 Zero Range	Selects the range within which the scale may be zeroed. Note that the indicator must be in standstill to zero the scale.	<b>100%</b> √ 1.9%, 2%, 20%
P6 Power on Zero Range	Set the zeroing range after the indicator powers on. 0 means deactivate Power On Zeroing	0, 2%, 3%, <b>20%</b> √ 100%
P7 Motion Band	Sets the level at which motion is detected by comparing the present display update with the previous one. If motion is not detected for two seconds or more, the scale is in standstill and can process a Print or Zero command. Maximum value varies depending on the local regulations.	<b>1d</b> √ 3d, 5d 10d
P8 Digital Filter	Averages weight readings to produce higher stability. The higher the filter setting the greater the stability but the slower the indicator's response time. Choose Med unless a very fast response is needed	FAST <b>MED</b> √ SLOW
P9 Overload Limit	Selects the desired formula which determines the point at which the indicator shows overload. All selections are based on the primary unit selected in P8  "FS" = Full Scale in primary units	FS <b>FS+ 2%</b> √ FS + 1d FS + 9d
P10 Calibration Unit	Selects the primary base unit to be used in the calibration process. Also the default unit for normal operation. "1" = calibration unit is lb      "2" = calibration unit is kg	<b>1</b> √ 2
P11 Zero Calibration	Places the indicator into the zero calibration routine. Scrolling down with the <b>[ZERO]</b> key one level begins the procedure	Press <b>[ZERO]</b> key to begin sequence
P12 Span Calibration	Places the indicator into the span calibration routine. Scrolling down with the <b>[ZERO]</b> key one level begins the procedure	Press <b>[ZERO]</b> key to begin sequence
P13 View Calibration	Actuates the function that allows the user to view both the zero and span calibration value. The values displayed in this function are valid only after calibration (P11 and P12) have been successfully completed. Scrolling down with the <b>[ZERO]</b> key one level begins the procedure	Press <b>[ZERO]</b> key to begin sequence
P14 Key-in Zero	Allows the user to key in a known zero calibration value in case of memory loss in the field. Scrolling down with the <b>[ZERO]</b> key one level begins the procedure	Press <b>[ZERO]</b> key to begin sequence
P15 Factory Reset	This sub menu will reset all parameters in the "P" and "S" menu to the default setting. <b>USE WITH CAUTION!</b>	Press <b>[ZERO]</b> key twice to begin sequence
P16 Normal/Slave Mode Setting	Set the indicator to be normal or slave mode. "n" means normal; "s" means slave. Connect the indicator through RS232 with another indicator to be used an additional display for "slave mode".	<b>N</b> √ S

P17 Counting Mode setting	Activate / deactivate the counting mode. "1" is ON, "0" is OFF	0 <b>1</b> √
P18 Animal Mode	Set the divisions for animal weighing hold function	XXd
P19 Accumulation (SS Only)	Set accumulation modes: Automatic or Manual In Automatic mode, it saves weights automatically when it is stable.	Auto <b>Man</b> √

### 2.7 Communication Menu Descriptions

This section provides a more detailed description of the selections found in the User Menu Chart. Factory-set defaults are shown in bold with a checkmark (√).

NAME/CODE	DESCRIPTION	CODE/VALUE
S1 Baud Rate	Selects the baud rate for data transmission through the serial port	1200      2400 4800 <b>9600</b> √ 19200
S2 Data Bits and Parity	Selects the number of data bits and parity of serial transmission. "8n" = 8 data bits with no parity bit and one stop bit "7O" = 7 data bits with odd parity bit and one stop bit "7E" = 7 data bits with even parity bit and one stop bit "7n" = 7 data bits with no parity bit and two stop bits	<b>8n</b> √ 7O 7E 7n
S3 Mode of Serial Transmission	Selects when data will be sent out of the serial port to a printer or computer: "C" = Continuous Mode; Send Data continuously "d" = demand mode; send data when a PRINT command is issued from the printer, computer or indicator	C <b>d</b> √
S4 Display Check	Actuates the function that illuminates all digit segments, decimal points, LCD enunciators in a test sequence. Pressing the <b>[ZERO]</b> key to scroll down one level begins the test sequence	Press <b>[ZERO]</b> key to begin sequence
S5 Disable the lb/kg Key	Allows the lb/kg to be disabled so that an operator cannot accidentally press the key and change the displayed units. "0" = Disable the lb/kg key "1" = Enable the lb/kg key	0 <b>1</b> √
S6 Serial Port Mode	Selects the mode of the RS-232 serial port: Refer to Appendix B for more information "0" = Full Duplex Mode "1" = Print Ticket Mode	0 <b>1</b> √
S7 ID No. Enable	Allows the ID number to be disabled in the Print Ticket Mode. Valid only when <b>S6</b> is set to "1" "0" = Disable the ID No. "1" = Enable the ID No.	<b>0</b> √ 1
S8 ID No. Entry	Actuates the function that allows entry of a new ID No. Valid only when <b>S6</b> is set to "1". Pressing the <b>[ZERO]</b> key to scroll down one level begins the sequence.	0 - 999999 <b>123456</b> √
S9 No of Line Feeds	Actuates the function that allows entry of the desired number of line feeds to be printed in Print Ticket Mode. Valid only when <b>S6</b> is set to "1". Pressing the <b>[ZERO]</b> key to scroll down one level begins the sequence.	0 – 99 <b>8</b> √
S10 Handshaking Enable	Enables hardware handshaking for Print Ticket Mode. Valid only when <b>S6</b> is set to "1". "0" = Disable Handshaking "1" = Enable Handshaking	<b>0</b> √ 1



**LIBERTY SCALES INC**

**PS-IN202**

**USER'S MANUAL - WEIGHING INDICATOR**

S11 Print Header	Tells the printer to print the header information. Valid only when <b>S6</b> is set to "1". "0" = Do NOT Print Header    "1" = Print Header	<b>0</b> √ 1
S12 Back light set	Set back light mode: OFF, ON and Auto (when the display is idle, the back light will turn off automatically.)	OFF ON <b>AUTO</b> √
S13 Time Setting	Activate or deactivate the clock when the indicator is in the sleep mode (or idle) ON is activate, OFF is deactivate. Then press Zero key to enter the Date / Time setting. First set the Month/ Date/Year. Press up and down button to change the blinking numbers. Press Zero button to move forward. After the date is done, press Zero button to move to Time setting. When all done, press Zero button to save the changes.	ON <b>OFF</b> √

## Chapter 3 Calibration

The indicator is calibrated by following the procedures embedded in P11 (Zero) and P12 (Span) of the Setup Menu. Each procedure enters a value into the indicator's non-volatile memory:

P11 is the zero value (deadweight)

P12 is the span value (test weight).

The minimum test weight that can be used is 1% of the full-scale capacity. After the two calibration procedures are executed successfully, a record should be made of both calibration values in the Calibration Table below using the P 18 View procedure. **NOTE:** This chapter assumes that the indicator is in Setup ("P") Menu mode.

### Calibration Table

Indicator

Zero Calibration	
Span Calibration	
Serial Number	

### 3.1 Zero Calibration

- While in the Setup mode, scroll to "P 11", then scroll down once using the **[ZERO]** key to enter the zero calibration menu. The display will momentarily show "C 0" followed by a value. This value is the internal A/D count and is useful when trying to troubleshoot setup problems.
- Ensure there are no test weights on the platform and press the **[ZERO]** key again to zero out the displayed value.
- Press the **[NET/GROSS]** key to save the zero point value. The display will show "End C0" momentarily then revert back to P11. Proceed to the P12 span calibration to complete the indicator calibration.

### 3.2 Span Calibration

- While in the Setup mode, scroll to "P 12", then scroll down once using the **[ZERO]** key to enter span calibration menu.
- The display will momentarily show "C 1" for the span calibration, followed by a value with one flashing digit. This value will be zero with the Decimal Point parameter as selected in P10. Place the test weight on the weighing mechanism.
- Use the four direction keys to adjust the displayed value to the actual test weight value. Increment the flashing digit by pressing the **[UNITS]** key. Decrement the flashing digit by pressing the **[ZERO]** key. Pressing the **[PRINT]** key or the **[TARE]** key will change the position of the flashing digit.
- After setting the exact value, press the **[NET/GROSS]** key to save the value.

e. If the calibration was successful, the display will show "EndC1" momentarily, then go to "C2".

f. Repeat Steps b-e using different test weights then proceed to Step "C3".

g. Repeat Steps b-e using different test weights. Proceed to P12.

h. If the calibration was not successful, one of the error messages below will appear. Take the indicated action to correct the problem then perform a new calibration.

**"Err0"** - The calibration test weight or the adjusted keyed-in weight is larger than the full capacity of the scale. Change the calibration test weight or check the input data.

**"Err1"** - The calibration test weight or the adjusted keyed-in weight is smaller than 1% of the full capacity of the scale. Change the calibration test weight or check the input data.

**"Err2"** - The internal resolution of the scale is not high enough to accept the calibration value.

### **3.3 View calibration values**

**Note:** The values displayed in this procedure are valid only after a successful calibration has been performed using P11 and P12.

a. While in the Setup mode, scroll to "F 18", then scroll down once using the **[ZERO]** key to enter view calibration menu.

b. The display will momentarily show "CAL 0" followed by a value. This value is the zero calibration value and should be recorded in the table below. Press any key to continue.

c. The display will momentarily show "CAL 1" followed by another value. This value is the span calibration value and should also be recorded in the table below. Press any key to return to upper level (P13).

### **3.4 Key-in zero calibration value**

**Note:** This procedure is intended for emergency use only in the case of non-volatile memory loss. A valid zero calibration value, obtained from a successful P11 calibration procedure, must be used.

a. While in the Setup mode, scroll to "P14" then scroll down once using the **[ZERO]** key.

b. The display will momentarily show "CAL 0", followed by a flashing zero. Use the four direction keys (shown in FIG 1) to adjust the displayed value to the zero calibration value.

c. After setting the exact value, press the **[NET/GROSS]** key to save the value.

d. The display will show "E CAL 0" momentarily then revert back to P14.

### **3.5 Key-in span calibration value**

**Note:** This procedure is intended for emergency use only in the case of non-volatile memory loss. A valid span calibration value, obtained from a successful P12 calibration procedure, must be used.

a. While in the Setup mode, scroll to "P15", then scroll down once using the **[ZERO]** key.

- b. The display will momentarily show "CAL 1", followed by a flashing zero. Use the four direction keys (shown in FIG 1) to adjust the displayed value to the span calibration value.
- c. After setting the exact value, press the **[NET/GROSS]** key to save the value.
- d. If the entered value is greater than zero, the display will show "E CAL 1" momentarily then revert back to P20. If a value of zero is entered, the indicator will briefly show "Err 5" then revert back to the screen described above in Step b.

# Chapter 4 Operation

## 4.1 Display



FIG 9

## 4.2 Display Details

LCD Enunciator	LED Enunciator	Meaning
→0←	ZERO	Centre Zero enunciator. This light is illuminated whenever the displayed weight is within $\pm 0.25$ divisions of true zero
N	NET	The indicator is displaying the net weight
G	GROSS	The indicator is displaying the gross weight
T	TARE	The tare weight has been established in the system
lb/kg	lb, kg, PCS	Indicates the unit of the displayed weight. PCS = pieces
	STABLE	This light is illuminated whenever the scale is stable

## 4.3 Keyboard



FIG 10

**[UNITS]** Toggles the indicator between the available weight units if enabled in the User ("S") menu. Available weight units are lb and kg.

**[ZERO]** Sets the indicator to display zero provided the following conditions are met:  
 a. The indicator is displaying Gross weight.

- b. The displayed weight is within the zero reset range that is programmed in P4 of the Setup ("P") Menu.
- c. The scale is not in motion or in overload.

**[NET/GROSS]** Toggles the indicator between Gross weight and Net weight only if a Tare has been established.

**[TARE]** Used to establish a Tare provided the following conditions are met:  
a. The indicator is not at or below Gross zero.  
b. The scale is not in motion or overload.

**[PRINT]** Used to send weight information out to the serial port provided the scale is not in motion or overload.

#### **4.4 Weighing**

- a. Select the desired weighing unit by pressing the **[UNITS]** key until the desired unit is indicated on the display.
- b. If necessary, press the **[ZERO]** key to obtain a weight reading of zero.
- c. Place the object to be weighed on the scale's platter and allow the weight indication to stabilize. If the item weight exceeds the scale's weight capacity, it displays "□□□□□□".
- d. Read the weight shown on the display.

#### **4.5 Tare Function**

To weigh an item in a container, the weight of that container must first be subtracted from the overall weight to obtain an accurate weight reading. This is known as taring.

- a. Select the desired weighing unit by pressing the **[UNITS]** key until the desired unit is indicated on the display.
- b. If necessary, press the **[ZERO]** key to obtain a weight reading of zero.
- c. Place the empty container on the scale's platter and allow the weight indication to stabilize.
- d. Press the **[TARE]** key. The display shows zero weight and turns the NET indication on.
- e. Place the material to be weighed in the container and allow the weight indication to stabilize.
- f. Read the weight shown on the display.
- e. The display can be toggled between gross weight and net weight by pressing the **[NET/GROSS]** key.