

FEATURES

- ✓ Mild steel base, 304 stainless steel pan for easy cleaning
- ✓ Adjustable tilt display for convenient viewing
- ✓ Aluminum environmentally sealed single point load cell
- ✓ Adjustable feet provide exceptional traction
- ✓ Standard removable column and wall mounting option
- ✓ LS-7510 NTEP indicator with 6 digit, 0.9" display (LED standard)
- ✓ Check-weighing feature for quick portioning
- ✓ Units: lbs, kgs, (g, oz, lb:oz available on LCD indicator)
- ✓ Rechargeable battery (up to 72 hours continuous use) and AC operation
- ✓ Tare, Zero, Hold, Counting & Accumulation features
- ✓ Built-in RS-232 communication port
- ✓ Bubble level
- ✓ 5 year warranty on the platform & electronics
- ✓ US Legal For Trade CC #: 22-026

SPECIFICATIONS

- ✓ Power: 6V 4Ah rechargeable lead acid battery with 110V power supply
- ✓ Frequency: 50 or 60 Hz
- ✓ Serial Communications: Full duplex RS-232, 9600, 4800, 2400, 1200 bps; 8 data bits, 1 stop bits, no parity, no handshaking
- ✓ Operating Temperature: 5°F to 104°F (-4°C to 40°C)
- ✓ IP Rating: IP65
- ✓ Approvals: NTEP CC 22-026, Class III 5,000 d; Measurement Canada AM-5817, Class III 5,000 d

MODELS	DESCRIPTION	CAPACITY	PLATFORM SIZE	SHIPMENT WEIGHT
STANDARD (INC. INDICATOR AND COLUMN)				
LS-915-1212-100	MS1 Platform/SS2 Cover	100 LB X 0.02 LB	12" x 12" x 4" H	23 lbs
LS-915-1214-150	MS1 Platform/SS2 Cover	150 LB X 0.02 LB	12" x 14" x 4" H	23 lbs
LS-915-1616-300	MS1 Platform/SS2 Cover	300 LB X 0.05 LB	16" x 16" x 4.25" H	32 lbs
LS-915-1620-400	MS1 Platform/SS2 Cover	400 LB X 0.05 LB	16" x 20" x 4.25" H	38 lbs
LS-915-1818-400	MS1 Platform/SS2 Cover	400 LB X 0.05 LB	18" x 18" x 4.25" H	38 lbs
LS-915-2020-500	MS1 Platform/SS2 Cover	500 LB X 0.1 LB	20" x 20" x 4.25" H	62 lbs
LS-915-1824-500	MS1 Platform/SS2 Cover	500 LB X 0.1 LB	18" x 24" x 5.5" H	64 lbs
LS-915-2424-500	MS1 Platform/SS2 Cover	500 LB X 0.1 LB	24" x 24" x 5.5" H	70 lbs
LS-915-2424-1K	MS1 Platform/SS2 Cover	1,000 LB X 0.2 LB	24" x 24" x 5.5" H	70 lbs
LS-915-3030-1K	MS1 Platform/SS2 Cover	1,000 LB X 0.2 LB	30" x 30" x 5.5" H	70 lbs
WITH STAINLESS BALL TRANSFER TOP (INC. INDICATOR AND COLUMN) ALSO AVAILABLE IN STAINLESS STEEL				
LS-915BT-1616-300	Ball Transfer Cover	300 LB X 0.05 LB	16" x 16" x 4.25" H	32 lbs
LS-915BT-2020-500	Ball Transfer Cover	500 LB X 0.1 LB	20" x 20" x 4.25" H	62 lbs
LS-915BT-2424-500	Ball Transfer Cover	500 LB X 0.1 LB	24" x 24" x 5.5" H	70 lbs
LS-915BT-2424-1K	Ball Transfer Cover	1,000 LB X 0.2 LB	24" x 24" x 5.5" H	70 lbs
WITH STAINLESS ROLLER CONVEYOR TOP (INC. INDICATOR AND COLUMN) ALSO AVAILABLE IN STAINLESS STEEL				
LS-915RT-1818-400	Roller Top Cover	400 LB X 0.05 LB	18" x 18" x 4.25" H	38 lbs
LS-915RT-2424-500	Roller Top Cover	500 LB X 0.1 LB	24" x 24" x 5.5" H	70 lbs
LS-915RT-2424-1K	Roller Top Cover	1,000 LB X 0.2 LB	24" x 24" x 5.5" H	70 lbs

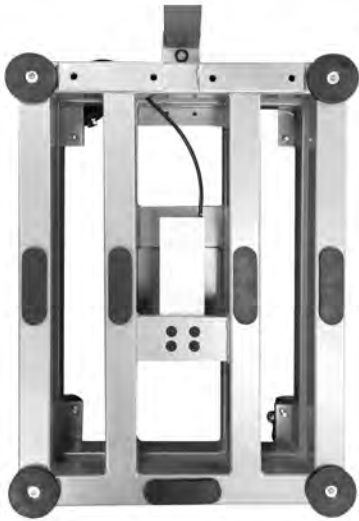

OPTIONAL ACCESSORIES

Printer
Remote Display
Software

FEATURES

- ✓ Designed for speed and accuracy with an extremely heavy-duty platform, built-in back rails, and wheels
- ✓ Ideal for busy shipping docks, outdoor markets, manufacturers, food processing, and other bulk sales
- ✓ High Resolution with overload protection
- ✓ Some sizes can have wheels replaced by level feet
- ✓ Standard Package Includes: Platform, Shroud, Indicator (Legal for Trade), Load Cells, Column, Wheels, Hardware
- ✓ US Legal For Trade CC #: 22-026
- ✓ Factory Calibrated
- ✓ Overload Protection
- ✓ 5-year warranty on parts

SPECIFICATIONS

Pan/Frame Material: Alloy Steel
Accuracy Class (SL-7510): 5000 e
Resolution: Display 30,000; ADC 2,000,000
Zero Stability Error: TK0 < 0.1 μ V//K
Span Stability Error: TKspn < \pm 6 ppm//K
Sensitivity (Internal): 0.3 μ V/d
Input Voltage: -30 ~ 30mV DC
Excitation Circuit: 5 VDC, 4 wire connection (+Exec, -Exec, +Sig, -Sig);
 Maximum 6 x 350 Ω load cells
Power: AC100~250V;
 Rechargeable battery optional
Temperature/Humidity: -10 $^{\circ}$ C ~ +40 $^{\circ}$ C; \leq 90%RH
Storage Temperature: -40 $^{\circ}$ C ~ +70 $^{\circ}$ C;

MODELS	CAPACITY in lb	ACCURACY	PLATFORM SIZE
LS-915BW-1824-500	500 lb	0.1 lb	18"x24"
LS-915BW-2424-500	500 lb	0.1 lb	24"x24"



FEATURES

- ✓ Stainless Steel scale and indicator made to be easily sprayed down for washing
- ✓ Welded sturdy construction
- ✓ The ideal weighing solution for applications such as portion control, food processing, straight weighing, or over/under weighing
- ✓ High accuracy single point strain gauge aluminum load cell
- ✓ Designed for speed and accuracy with an extremely heavy-duty platform and rugged stainless steel enclosure
- ✓ Ideal for busy shipping docks, outdoor markets, manufacturers, food processing, and other bulk sales
- ✓ High resolution with overload protection
- ✓ Standard package includes: platform, shroud, indicator (Legal for Trade), load cells, column, level feet, and all necessary hardware
- ✓ NTEP Class III, 5000 divisions
- ✓ US Legal For Trade CC #: 22-026
- ✓ Factory Calibrated
- ✓ Overload Protection
- ✓ 5-year warranty on parts

SPECIFICATIONS

Pan/Frame Material: Stainless Steel
Accuracy Class (SL-7510): 5000 e
Resolution: Display 30,000; ADC 2,000,000
Zero Stability Error: TK0 < 0.1 μ V//K
Span Stability Error: TKspn < \pm 6 ppm//K
Sensitivity (Internal): 0.3 μ V/d
Input Voltage: -30 ~ 30mV DC
Excitation Circuit: 5 VDC, 4 wire connection (+Exec, -Exec, +Sig, -Sig);
 Maximum 6 x 350 Ω load cells
Power: AC100~250V;
 Rechargeable battery optional
Temperature/Humidity: -10 $^{\circ}$ C ~ +40 $^{\circ}$ C; \leq 90%RH
Storage Temperature: -40 $^{\circ}$ C ~ +70 $^{\circ}$ C;

OPTIONAL ACCESSORIES

Printer
 Remote Display
 Software

MODELS	CAPACITY in lb	ACCURACY	PLATFORM SIZE
LS-915SS-HP-6	6 lbs	0.0002 lb	10"x10"
LS-915SS-HP-15	15 lbs	0.0005 lb	10"x10"
LS-915SS-HP-30	30 lbs	0.001 lb	10"x10"
LS-915SS-HP-60	60 lbs	0.002 lb	10"x10"
LS-915SS-1212-100	100 lbs	0.02 lb	12"x12"
LS-915SS-1214-100	100 lbs	0.02 lb	12"x14"
LS-915SS-1616-300	300 lbs	0.05 lb	16"x16"
LS-915SS-1620-400	400 lbs	0.05 lb	16"x20"
LS-915SS-1818-400	400 lbs	0.05 lb	18"x18"
LS-915SS-2020-500	500 lbs	0.1 lb	20"x20"
LS-915SS-1824-500	500 lbs	0.1 lb	18"x24"
LS-915SS-2424-500	500 lbs	0.1 lb	24"x24"
LS-915SS-2424-1000	1000 lbs	0.2 lb	24"x24"



FEATURES

- ✓ For use with LS-915-SS Bench Scales
- ✓ Stainless Steel welded construction
- ✓ Ideal for use in the food and chemical industry
- ✓ Wheeled design for effortless smooth movement, easy portability and fast setup
- ✓ Locking rear casters allows for stability
- ✓ Adjustable cart legs can be raised or lowered to fit into assembly lines
- ✓ Rear handle for easy transporting
- ✓ Remove indicator stand
- ✓ Tilt-able indicator for eliminating glare
- ✓ 1,000 lb capacity

MODELS	PLATFORM SIZE	SHIP WT.
LS-915-CT18	18"x24"	50 lbs
LS-915-CT24	24"x24"	70 lbs

* SHOWN WITH BENCH SCALE (SOLD SEPARATELY)

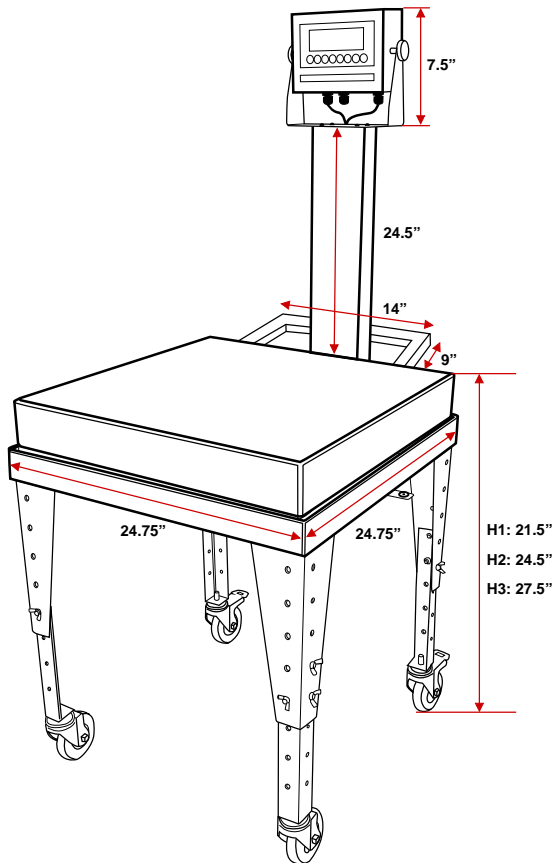

* SHOWN WITH 4 CASTERS (OPTIONAL)



FEATURES

- ✓ Perfect for shipping and food industries
- ✓ Easy-to-clean stainless steel indicator and platter
- ✓ Lightweight and designed for effortless transportation
- ✓ Built-in battery (100 hours in one charge)
- ✓ 5-year warranty

MODEL	MATERIAL	CAPACITY	PLATFORM SIZE	INDICATOR
LS-916-16X12	Stainless steel	400 lbs x .02 lb	16" (L) x 12" (W) x 4" H	LS-7512-SS-C
LS-916-18X18	Stainless steel	600 lbs x .05 lb	18" (L) x 18" (W) x 4" H	LS-7512-SS-C
LS-916-20X16	Stainless steel	600 lbs x .05 lb	20" (L) x 16" (W) x 4" H	LS-7512-SS-C
LS-916-24X24	Stainless steel	1000 lbs x .2 lb lb	24" (L) x 24" (W) x 4" H	LS-7512-SS-C