

ASSEMBLY INSTRUCTIONS FOR YOUR 11515 BED

* READ ALL INSTRUCTIONS BEFORE ASSEMBLING BED. KEEP INSTRUCTIONS FOR FUTURE USE.
* NEVER USE PLASTIC SHIPPING BAGS OR OTHER PLASTIC FILM AS MATTRESS COVERS BECAUSE THEY CAN CAUSE SUFFOCATION.

WARNING: THE PROPER USE OF THIS CRIB IS IMPORTANT FOR YOUR BABY'S SAFETY. TO KEEP YOUR BABY SECURE AND SAFE, AND TO AVOID POTENTIAL INJURY OR DEATH, CAREFULLY READ AND FAMILIARIZE YOURSELF WITH ALL WARNINGS, CAUTIONS AND INSTRUCTIONS IN THE INSTRUCTION BOOKLET. KEEP THIS INSTRUCTION BOOKLET FOR FUTURE USE.

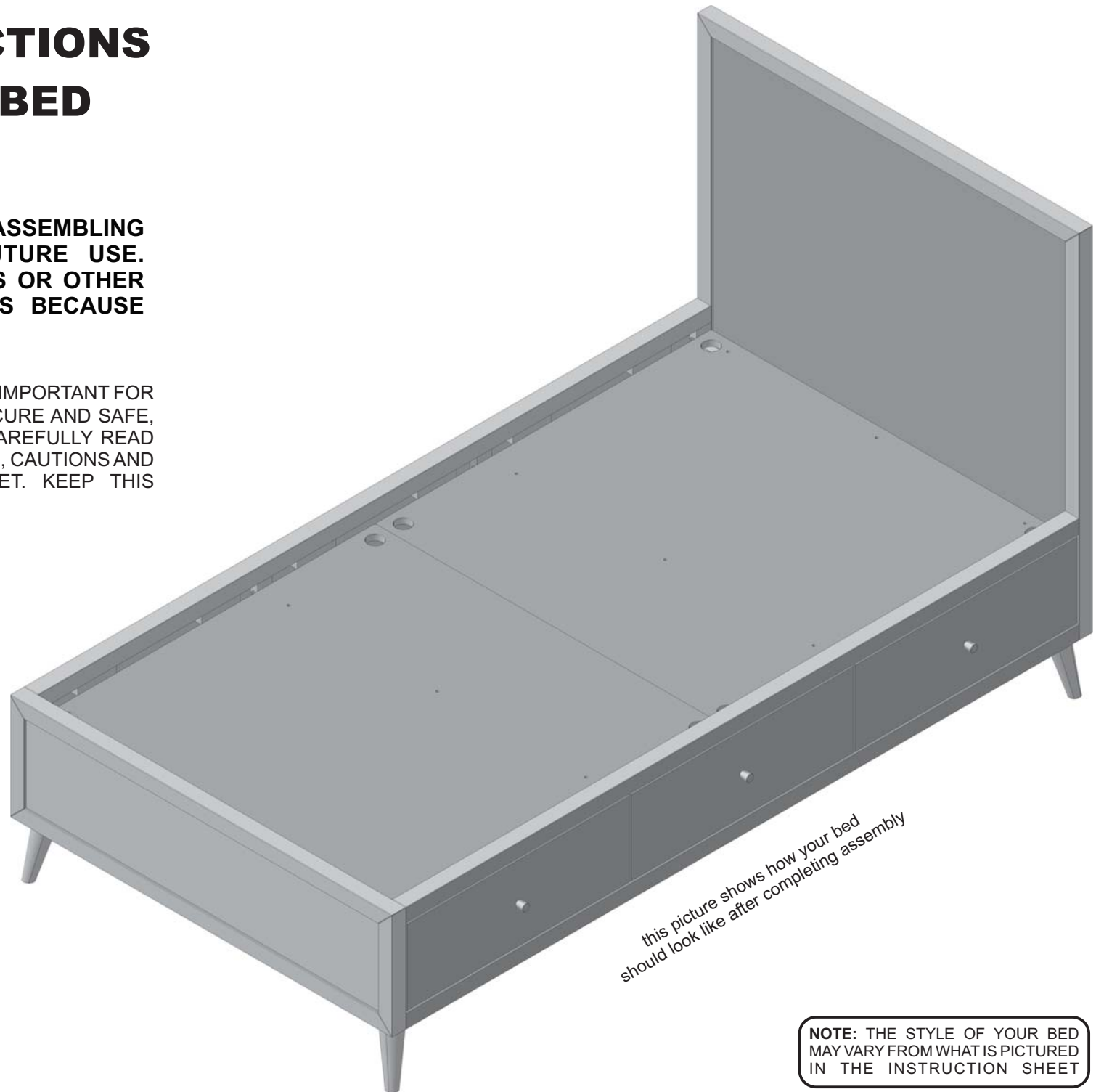

this picture shows how your bed
should look like after completing assembly

Romina[®]
Furniture

20 Corporation Row, Edison, NJ 08817
Phone (718) 478 5100, Fax (718) 478 5117
www.rominafurniture.com

NOTE: THE STYLE OF YOUR BED
MAY VARY FROM WHAT IS PICTURED
IN THE INSTRUCTION SHEET

11515 BOX CONTENT

Please locate and confirm that you have the following parts:

- HB. headboard = 1
- BF. bed frame = 1
- OL. oblique legs = 4
- SL. straight legs = 2

and one bag of hardware with the following:

1. Allen wrench = 1
2. Allen bolt (15mm - 9/16" - w/o centering tip) = 2
3. Allen bolt (20mm - 3/4" - w/o centering tip) = 10
4. Allen bolt (50mm - 1 15/16") = 4

Required tools: Allen wrench (supplied)

CAUTION: Do not use a power screwdriver which can cause screws to break or strip.

Note: The letters which identifies a part are the initials of the respective part name (such method is employed to facilitate parts recognition between the drawings and the parts list).

NOTE: THE STYLE OF YOUR BED MAY VARY FROM WHAT IS PICTURED IN THE INSTRUCTION SHEET

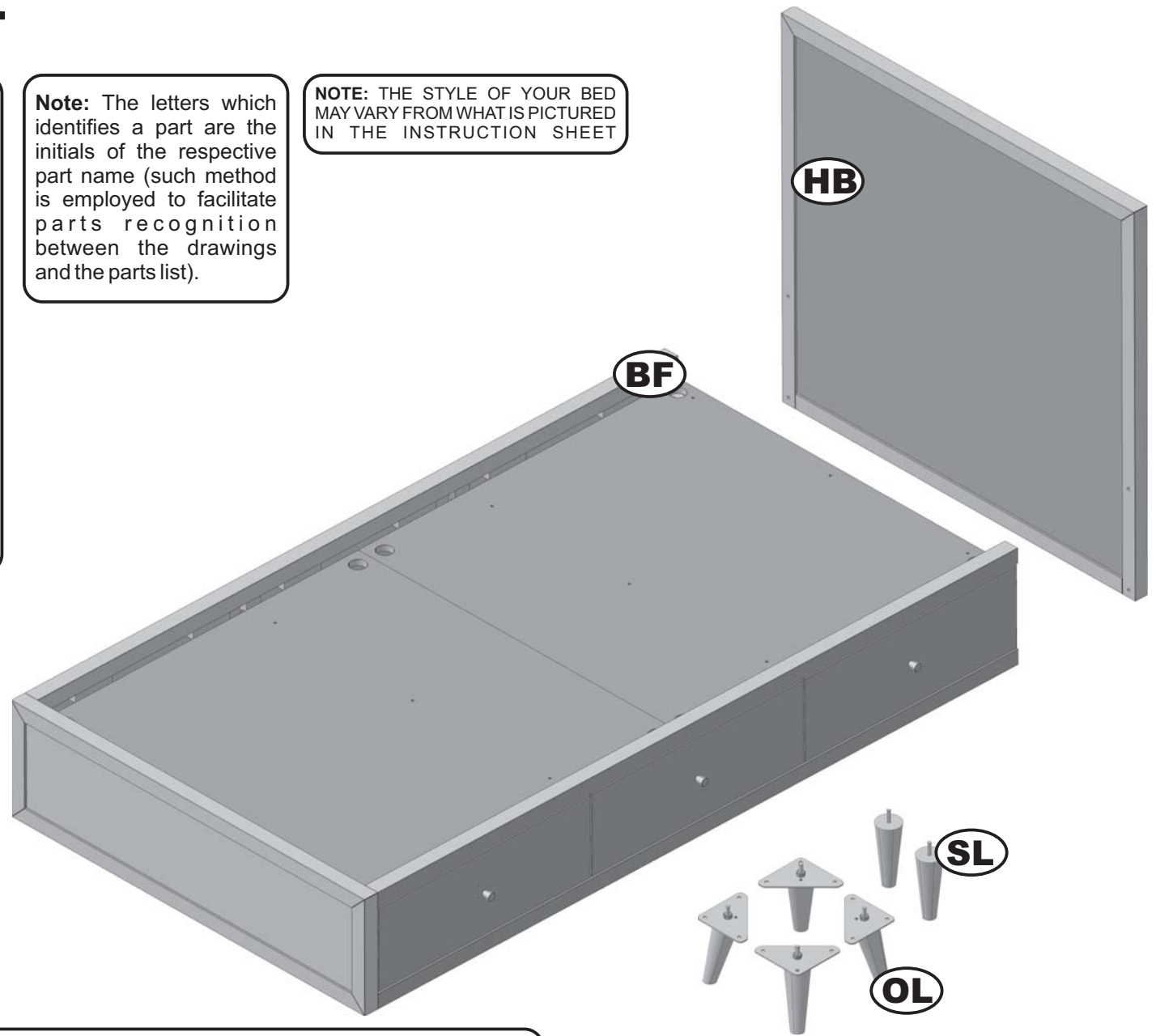
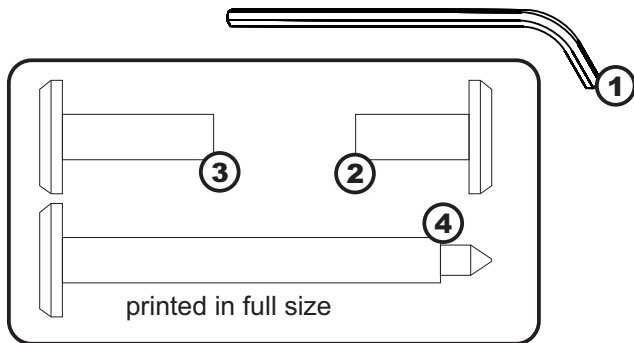

Note: The item number of your product is located on the inner side of the bed frame, on a black and white label. Please, refer to this number in the event that you need to call ROMINA FURNITURE or your local distributor. Thank you.

Note: During the assembly process whenever using screws or bolts, check each by placing the screw / bolt on the hardware diagram which is drawn in actual size. Be sure to use the proper size and shape specified in the instructions. Be sure to **COMPLETELY TIGHTEN** the screws / bolts when you are asked to do this.

STEP 1 (Two adults are required to complete this step)

Attach the headboard (HB) to the bed frame (BF) using four bigger Allen bolts (4) and the Allen key.

Do not completely tighten the bolts at this step, you will be asked to do this later.

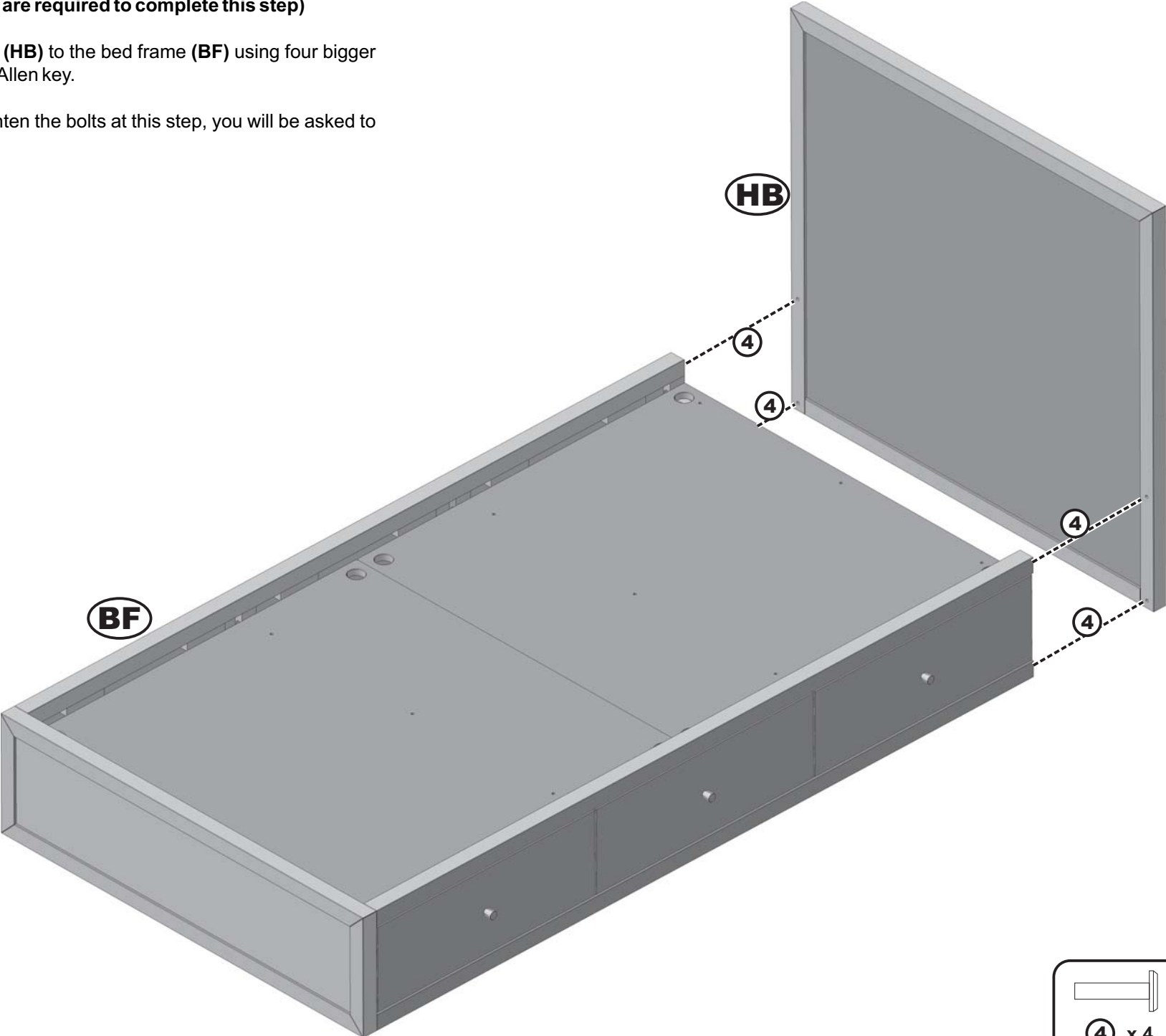

FIGURE 1

A set of icons for assembly requirements. On the left is a square box containing a horizontal Allen key and the text '4 x 4'. To the right of the box are two stylized human figures representing two adults. Further right is a curved arrow pointing upwards, with the word 'REQUIRED' written vertically next to it.

STEP 2 (Two adults are required to complete this step)

Turn the bed with the side with no drawers on the floor, taking care not to scratch its finish.

Attach the oblique legs (**OL**) to the bed using ten medium Allen bolts (**3**), two smaller Allen bolts (**2**) and the Allen key. Take care to insert the smaller Allen bolts (**2**) in the straight corners of the metallic triangles from the headboard side!

Completely tighten all **10** medium Allen bolts (**3**) and **both** smaller Allen bolts (**2**) used before.

Insert the straight legs (**SL**) into the metallic inserts found in the middle beam of the bed. The straight legs of the bed are a little shorter than the oblique ones so you can adjust their vertical position by screwing or unscrewing them.

Turn the bed in its normal position, taking care not to scratch its finish.

Completely tighten all **4** bigger Allen bolts (**4**) used to attach the headboard.

REMINDER

You have to completely tighten **16** Allen bolts distributed as following:

- **4** bigger bolts (**4**) in the headboard;
- **10** medium bolts (**3**) in the oblique legs;
- **2** smaller bolts (**2**) in the backside oblique legs.

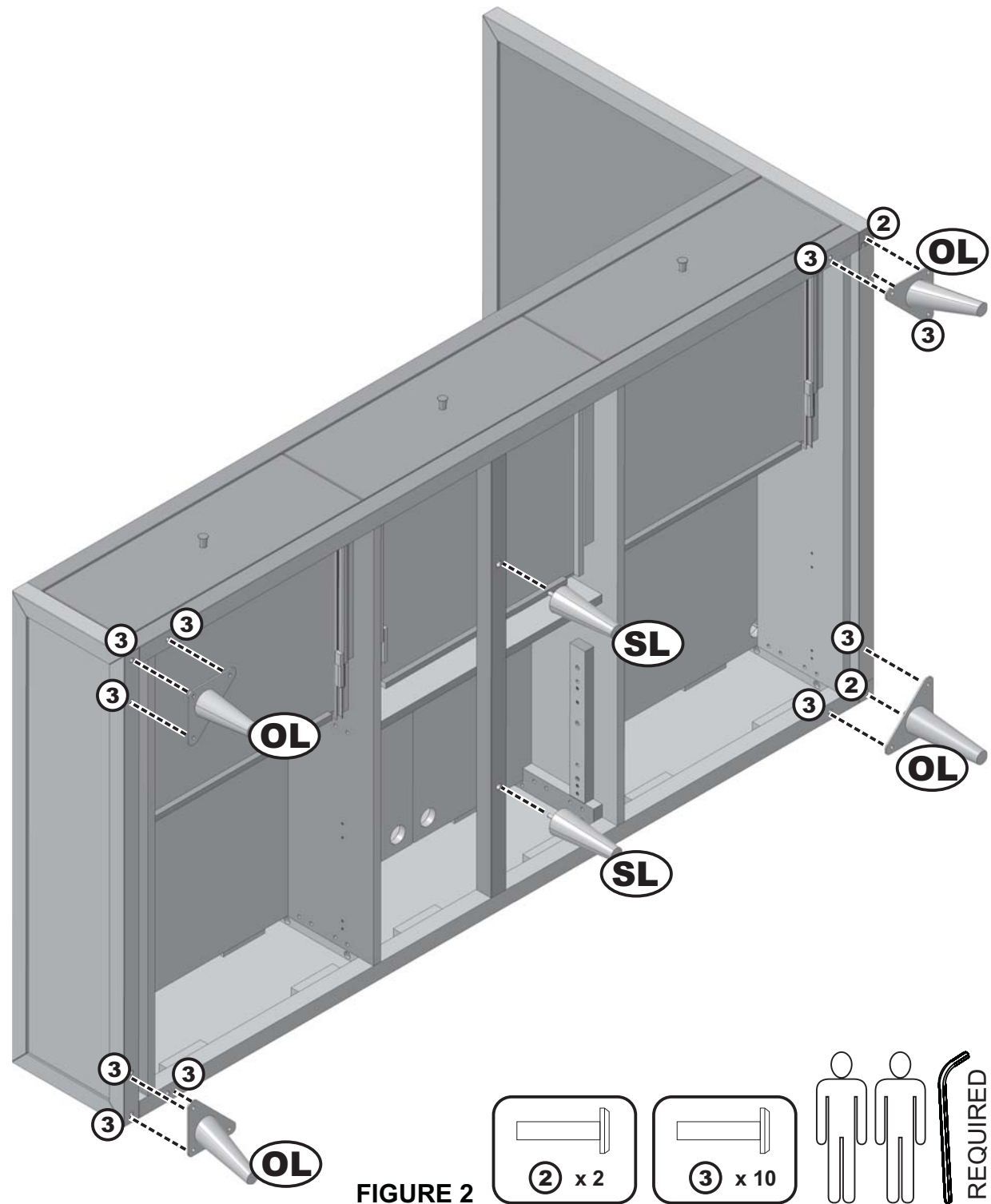
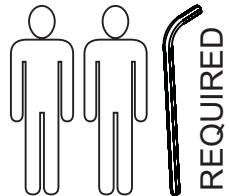

FIGURE 2

WARNING!
COMPLETELY TIGHTEN!



GENERAL FURNITURE CARE TIPS

- Wood, like any natural material is likely to present variations of grain and texture which will result in slight color variations or richness in the finish. These differences make each Romina Furniture item as beautiful and unique as you and your baby are.
- To preserve the initial appearance and functionality of your furniture, it is recommended that all furniture items be used in accordance with their intended design.
- Special water-based finishes are used to make this furniture safe for your baby. These finishes may be more delicate than those used on adult furniture thus requiring careful maintenance.
- Constant rubbing or mechanical interaction with sharp/hard objects such as belt buckles, jeans' zippers or buttons will likely damage the finish on your furniture. When placing or retrieving items onto the furniture, always set them down and pick them up, do not "slide" them. Items placed onto the horizontal surfaces must be moved/rotated to prevent discoloration in the finish.
- Exposure to extreme variations of environmental conditions such as humidity and temperature can affect the finish quality due to wood sudden expansion or shrinkage. It is recommended that the room temperature be maintained in between 65 and 75 degrees Fahrenheit and a relative humidity of 35 – 40 %. Do not place items which are too hot or too cold directly onto the finished surfaces!
- Use caution when using a humidifier or vaporizer. Excessive moisture is harmful to the furniture causing the finish to peel and the wood to warp.
- Wipe up spills promptly. If water or other liquids stay in contact with the furniture for a long period of time, they can cause the finish to turn white or discolor. Alcohol or solvent containing substances or materials will permanently damage the finish.
- In general, furniture should not be placed in front or too close to air-conditioning outlets, fireplaces, heaters or humidifiers. Direct sunlight and ultraviolet rays will cause colors to fade, affect the luster and smoothness of the finish and in most cases may cause hairline cracks in the finish. White finishes will yellow naturally over time; exposure to direct sunlight will accelerate this natural process. Please note that all wood essences will darken over time along with the natural aging process which is not considered to be a quality defect.
- To clean the furniture, use a damp cloth immediately followed by wiping with a dry cloth. Do not allow water to stay in contact with the finish as it will damage the finish.
- If you need to put your furniture into storage for any period of time, avoid placing it in damp basements or hot attics. Air flow around and under the furniture should be allowed. Do not place furniture too close to walls, do not stack anything on it and do not cover it entirely.
- When using a vinyl changing pad or similar plastic accessories, make sure to use a fabric felt underneath. Certain plastics have ingredients that can react with and damage the finish. It is recommended to rotate the changing pad's position frequently to avoid finish discoloration.

Regular cleaning with mild soap on a soft cloth, followed by a clean damp cloth, then a dry cloth, will preserve the original luster and beauty of the fine finish of your Romina Furniture product.



Thank you for being one of our distinguished clients.

Romina[®] *Team*
Furniture

Visit

www.rominafurniture.com

for updates, special offers and more new designs.