

A T  
B O  
since 1967

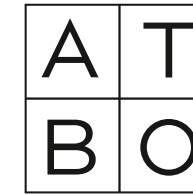

MORE  
THAN  
A BOOK  
CASE





since 1967

## TRADITION AND THE NEW ERA



### TRADITION

ATBO is a cabinetmaker's tale that began in 1967. In 2019, ATBO came under new ownership, and we are dedicated to continuing ATBO's tradition for craftsmanship and durable quality. Now, in 2023, our workshop is still located on Falster in Southern Denmark, where the well-known ATBO bookcases are still produced today.

We assemble our bookcases by hand, using strong and beautiful finger joints that lend the bookcase an almost graphic decorative touch. Finger joints have become a signature feature, along with the shadow-groove trim – a detail that lightens the visual expression of the bookcase. In other words, we hand-carry the bookcase through the long process from the planks arrive in the workshop through the selection, cutting, milling, sanding, joining, gluing and drying to the final assembly.

### TRACEABLE WOOD AND NEW ACCESSORIES

ATBO is more than a bookcase. It is a manifestation of proud design and cabinetmaking history. We cherish and preserve this history because it has its roots in the natural material and our high quality standards. All our wood is certified, which means that we support responsible forestry and help preserve and develop the local environments that the forest and the forest workers are a part of. We use only certified and traceable wood and no plastic or metal in our production. All the bookcases are only treated with natural oil or water-based paint.

The ATBO bookcase is a storage module that you can use in many different settings - the hall, bedroom, office, nursery, living room or kitchen. The square construction remains the optimal utilization of space.

No other solution is more efficient or practical.

We've updated the surrounding elements and demonstrated how optimal the ATBO bookcase is in a modern context. Thus, we have developed everything that surrounds the book-case, including doors, knobs and a frame that raises the bookcase from the floor and creates flexible design options, just as a top plate in marble opens a world of functionalities and expressions.

### THE NEW ERA

ATBO is more than a bookcase, as is demonstrated by our launch of a series of furniture collections. Cocoon Lounge Chair was our first new furniture design. Now it is part of The Cocoon Family, which also includes a dining chair. We are proud of welcoming The Cloud Table Family, adding new sizes and colours, and The Gubi Collection which includes the Sailor Sofa designed especially for ATBO. Though the future furniture collections all share a more playful and not-so-square expression, they contain the same emphasis on skilled craftsmanship and quality materials which has been worked into our bookcases for more than half a century.

### WELCOME

Peter Mondrup  
CEO & OWNER.





<b>ATBO AND THE NEW ERA</b>	<b>5</b>
<b>FURNITURE &amp; LIGHT</b>	<b>9</b>
<b>The Cocoon Family</b>	<b>10</b>
<i>The Cocoon Dining Chair</i>	<b>12</b>
<i>The Cocoon Lounge Chair</i>	<b>16</b>
<b>The Cloud Table</b>	<b>20</b>
<b>The GUBI Collection</b>	<b>26</b>
<i>Sailor Sofa</i>	<b>26</b>
<i>Grand Piano Sofa</i>	<b>30</b>
<i>Bonaparte Sofa, Chair, Ottoman</i>	<b>32</b>
<b>The PS38 Lamp</b>	<b>34</b>
<b>Floris Mirror</b>	<b>40</b>
<b>ATBO Mirror</b>	<b>42</b>
<b>THE CLASSIC COLLECTION BOOKCASES</b>	<b>45</b>
<b>Oak</b>	<b>48</b>
<b>Aash</b>	<b>50</b>
<b>Bamboo</b>	<b>54</b>
<b>Walnut</b>	<b>56</b>
<b>Divider</b>	<b>58</b>
<b>Bedside Table</b>	<b>60</b>
<b>Half Hallway</b>	<b>62</b>
<b>ACCESSORIES BOOKCASES</b>	<b>65</b>
<b>Rattan</b>	<b>66</b>
<b>Frame</b>	<b>68</b>
<b>Marble Top</b>	<b>70</b>
<b>Glass Knobs</b>	<b>72</b>
<b>OVERVIEW BOOKCASES &amp; ACCESSORIES</b>	<b>74</b>
<b>WOOD LIBRARY</b>	<b>76</b>
<b>DESIGNERS</b>	<b>78</b>
<b>CONTACT</b>	<b>83</b>

## FURNITURE AND LIGHT

# THE COCOON FAMILY

The Cocoon Family is a design family that blurs the boundary between furniture and architecture. It is inspired by the organic modernism of the 60s, where soft and sculptural shapes melt together. Our mission has been to create new icons. Timeless but still playful designs that fit both at home and outside the home.



# THE COCOON DINING CHAIR

The vision behind The Cocoon Dining Chair has been to create an iconic and contemporary tribute to the parents of Danish chairs - Hans Wegner, Finn Juhl, and Nanna Ditzel, just to name some. The Cocoon Dining Chair is an ambitious and uncompromised design combining a sustainable design vision with virtuous craftsmanship. This is a chair that is well designed, well made, and made to last.

## DIMENSIONS

H80 B60 D52 SEAT HIGHT 45 CM

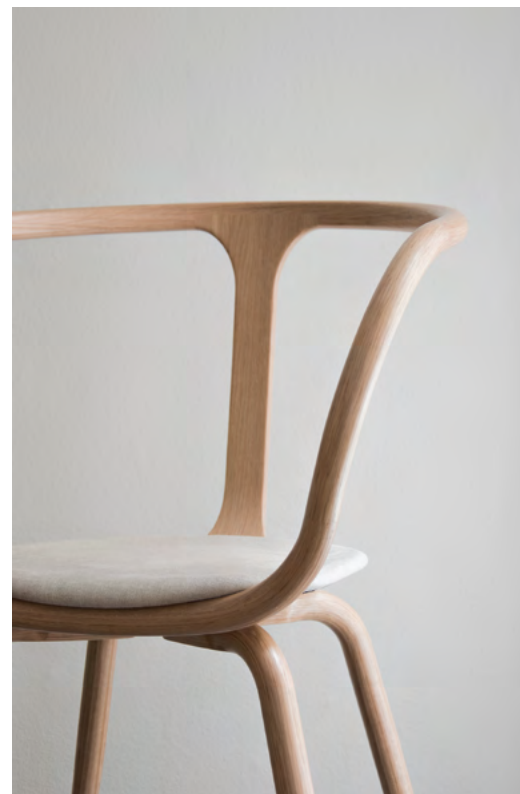
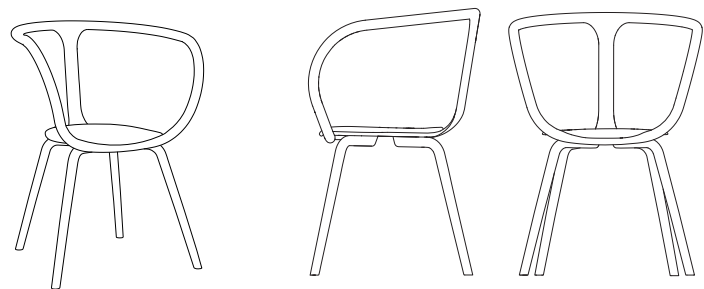

design

KEVIN HVIID / THE COCOON DINING CHAIR





design

KEVIN HVIID & MARTIN KECHAYAS /THE COCOON LOUNGE CHAIR

# THE COCOON LOUNGE CHAIR

The Cocoon Lounge Chair combines recognizable materials with new expressions. French rattan and steam-bent oak come together in a light and warm expression.

## DIMENSIONS

H80 B60 D52 SEAT HIGHT 45 CM

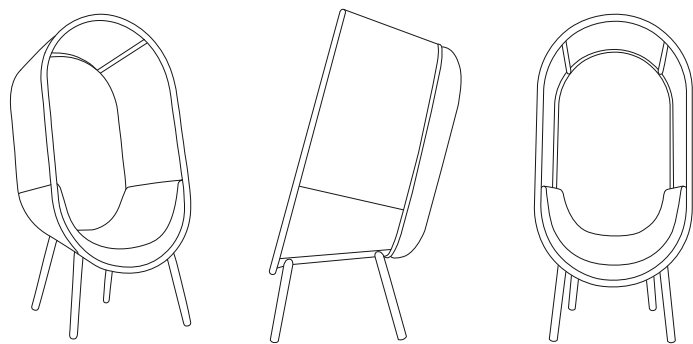

design

KEVIN HVIID & MARTIN KECHAYAS /THE COCOON LOUNGE CHAIR



**The Cocoon Lounge Chair is a new furniture type. A furniture story with its own table of contents. A safe and restful space that embraces and contains you.**

# THE CLOUD TABLE

The Cloud Table is the sky dragged down to earth and into your home. Its shape is an aesthetic complement to the usual sharp edges that are common today.

## ORGANIC SHAPE

The Cloud Table brings organic shapes to your home and comes in 6 sizes, ranging from a small bedside table to a 12 person dining table.

## MATERIALS

The tabletop is made from white silk laminate which is a versatile material that keeps its look and feel for decades.



design

NICOLINE OLSEN & PER BUCHARDT/THE CLOUD TABLE





## DIMENSIONS AND MATERIALS

THE CLOUD TABLE BRINGS ORGANIC SHAPES TO YOUR HOME AND COMES IN 6 SIZES, RANGING FROM A LOW SIDE TABLE TO A 12 PERSON DINING TABLE.

THE TABLETOP IS MADE FROM WHITE SILK LAMINATE WHICH IS A VERSATILE MATERIAL THAT KEEPS ITS LOOK AND FEEL FOR DECADES. THE TABLETOP IS PLACED ON WHITE PAINTED STEEL CONES.

DINING TABLE / 220 B140 X L220 X H73

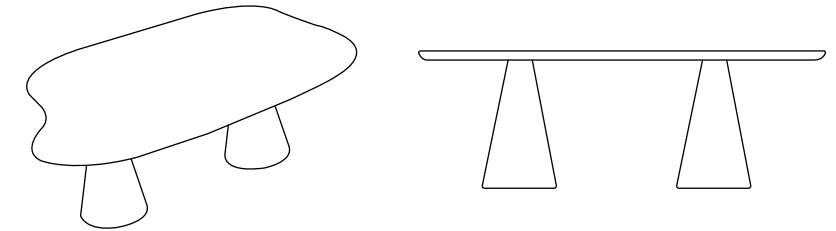

DINING TABLE / Ø140 Ø140 X H73

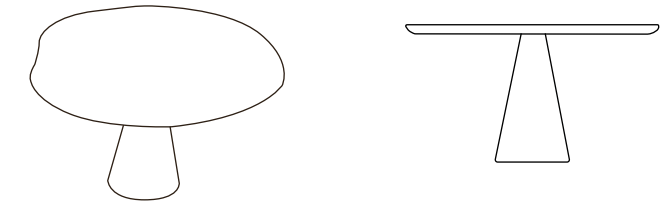

DINING TABLE / Ø100 Ø100 X H73



SIDE TABLE HIGH / Ø70 X H60



SIDE TABLE LOW / Ø70 X H44



LOUNGE TABLE LOW / Ø100 X H44



# THE GUBI OLSEN COLLECTION

## SAILOR SOFA

Sailor is a modular sofa design that anticipates and meets any interior design need. The soft demi-circle of the upholstery gives the sofa a unique and distinctive expression unlike any other modular sofa, adding a dynamic texture contrasting the purity of the design lines.





### DIMENSIONS AND MATERIALS

CENTER MODULE H83 X W88 X D88 / SEAT HEIGHT 40 CM  
POUF MODULE H40 X W88 X D88  
CORNER MODULE H83 X W115 X D88 / SEAT HEIGHT 40 CM

UPHOLSTRY ALL AVAILABLE FABRICS AND COLOURS  
SHELL WOOD, FOAM AND SPRINGS  
BASE WOOD, BLACK

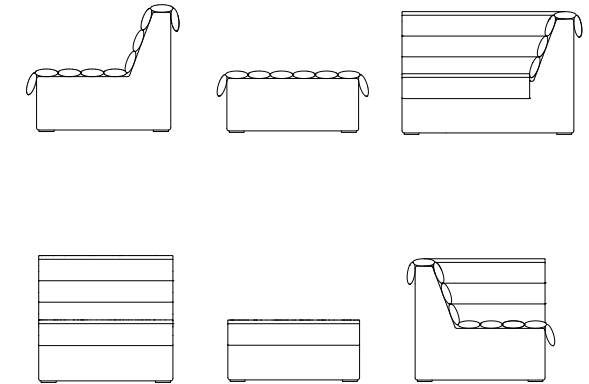

### MIX YOUR SAILOR SOFA

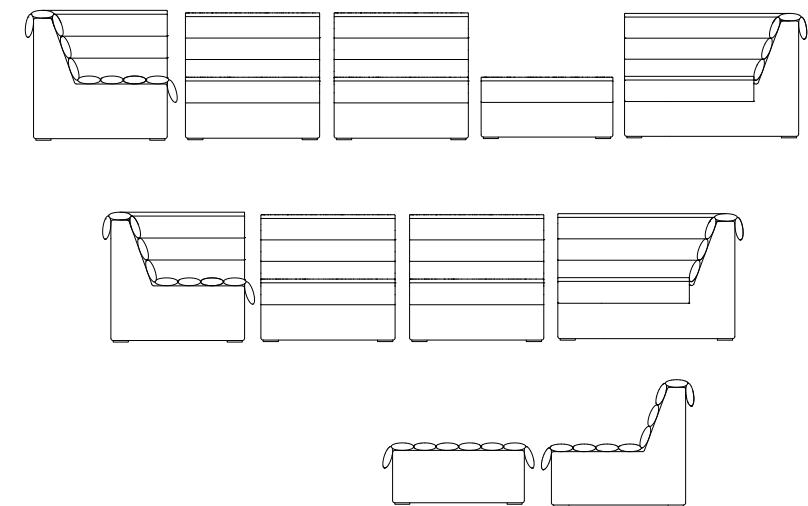



# GRAND PIANO SOFA

Grand Piano Sofa is inspired by the organic and sensual shapes of the grand piano. An elegant sofa that transforms its expression with the choice of fabric.

Grand Piano was designed in 1982 and relaunched in 2020 by ATBO.

Grand Piano Sofa plays with both meaning and material: deconstruction of a grand piano - retold in the shape of a sofa.

## DIMENSIONS AND MATERIALS

GRAND PIANO SOFA      H92 X D74 X L 220 / SEAT HEIGHT 43 CM

GRAND PIANO IS BUILT ON A HANDMADE WOODEN FRAME, WITH SPRINGS, FOAM AND UPHOLSTERY. HAND-TURNED SOLID OAK LEGS.

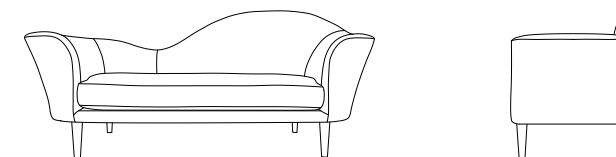



design

GUBI OLSEN/BONAPARTE SOFA/CHAIR/OTTOMAN

# THE BONAPARTE COLLECTION

## SOFA, LOUNGE CHAIR, OTTOMAN

The organic shapes of the Lounge Chair, Sofa and Ottoman are expressions of a bold elegance - both individually and as a group.

### DIMENSIONS AND MATERIALS

BONAPARTE SOFA	H98 X D85 X L174 / SEAT HEIGHT 43 CM
BONAPARTE LOUNGE CHAIR	H97 X W75 X L76 / SEAT HEIGHT 43 CM
BONAPARTE OTTOMAN	H43 X W58 X L58 CM

THE BONAPARTE COLLECTION IS BUILT ON A HANDMADE WOODEN FRAME, WITH SPRINGS, FOAM AND UPHOLSTERY. HAND-TURNED SOLID OAK LEGS.

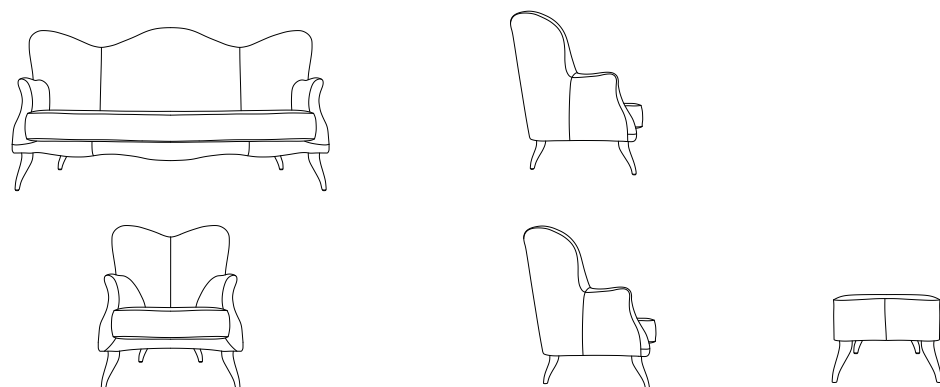

# THE PS38 LAMP

The shape of The PS38 Lamp as well as the original shade of green are directly linked to the source of inspiration. A modern interpretation of the organic design language, clearly visible in the contrasting shapes that make up the manifestation of the lamp: the leaf shaped lamp and the globe shaped opal glass covering the light source.

## PS38 WALL LAMP

With its naturally playful shape inspired by palm leaves, The PS38 Wall Lamp adds a subtleness to the lighting of the interior design.



design

PALLE SUENSON / PS38 LAMP

**PS38 TABLE LAMP**

The distinctive organic inspiration, rooted in plants, gives The PS38 Table Lamp a subtle elegance and offers versatility to the illumination of the interior design.





## DIMENSIONS

PS38 TABLE LAMP

HEIGHT: CM 45  
WIDTH: CM 33  
DEPTH: CM 25

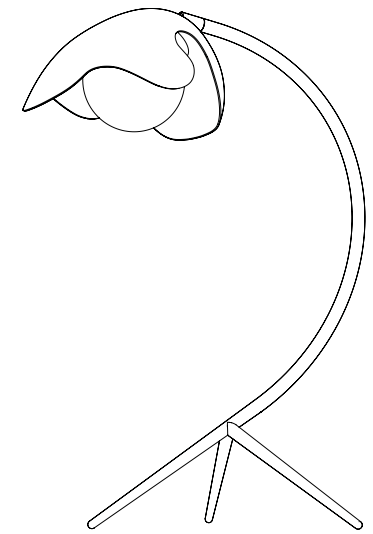

PS38 WALL LAMP  
WIRE WITH SWITCH

HEIGHT: CM 16  
WIDTH: CM 15  
DEPTH: CM 16

PS38 WALL LAMP  
HARD WIRED

HEIGHT: CM 16  
WIDTH: CM 15  
DEPTH: CM 16

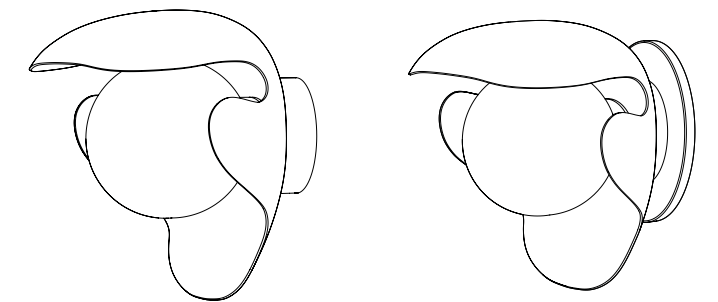

design

FLORIS H. FIEDELJIIJ /FLORIS MIRROR

# FLORIS MIRROR

ATBO is proud and honoured to be able to present this beautiful and unique design piece to the world once again.

The Floris Mirror, from Dutch designer Floris H. Fiedeldij, was originally produced by the famous and iconic design company Artimeta in 1950. Artimeta was one of the leading design-lighting and furniture factories at that time, collaborating with well-known designers, including the French designer Mathieu Matégot.

The Floris Wall Mirror creates a circular halo on your wall offering, not just a mirror or a light but, as a whole, an authentic design & art piece. It is decorated with a perforated metal frame in Cappuccino colour and an elegant brass edge where the light penetrates the design.

## DIMENSIONS

H80 B80 D7

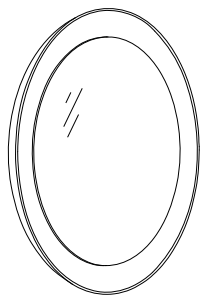

design

ATBO/ATBO MIRROR

# ATBO MIRROR

ATBO Mirror is made out of oak with matt lacquer or in black stained oak. The ATBO Mirror can be mounted to a wall both vertically and horizontally via the adjustable mount.

The ATBO Mirror comes in three different sizes; Medium, Large and Full body.

## DIMENSIONS

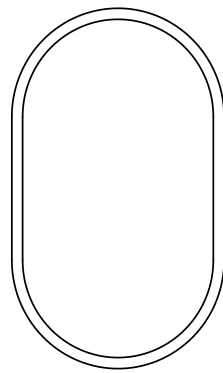

ATBO MIRROR MEDIUM H98XW59

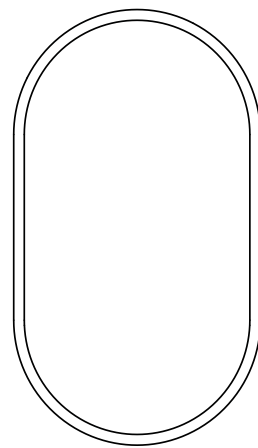

ATBO MIRROR LARGE H122XW70

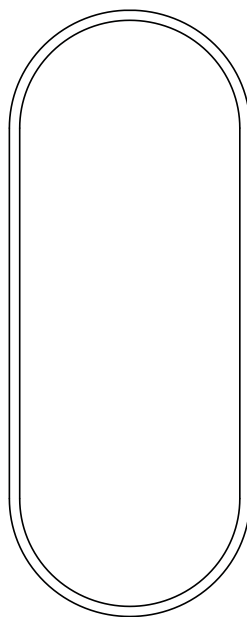

ATBO MIRROR FULL BODY H180XW70



THE CLASSIC COLLECTION  
BOOKCASES





# OAK

Oak is a classic wood type and incredibly well suited for furniture making. It is strong, durable and beautiful.

Use traditional oak as the basis for an untraditional presentation of your favourite objects.



# ASH

Ash is a light-coloured wood type that adds a modern feel to an interior.





Play with a variation of open and hidden spaces by combining doors and drawers in different sizes and depths to make the shelving wall a flexible setting for varying installations.

# BAMBOO

Bamboo is one of the most sustainable materials, as it absorbs extremely high amounts of CO<sub>2</sub>. The bookcases are made of bamboo stems that have been sliced, dried and compressed. The processing makes the material extra strong due to the crossed fibres.

Bamboo has a sensuous expression due to its natural golden glow. Use it in rooms where you would like a warm touch, for example to add a welcoming feel to your library or living room



# WALNUT

Walnut is an exclusive wood type. Walnut is dark and ranges from a deep warm expression to a cooler greyish look, depending on the finish.



# DIVIDER

Divider is both a bookcase and a room divider.

Use the wall as a background for this open bookcase to achieve a transparent look.



# BEDSIDE TABLE

ATBO's Bedside Table comes with a flexible shelf. The size of the bedside table is suitable for an additional small top drawer as well as a door to elegantly cover your storage.



# HALF HALLWAY

ATBO's Half Hallway offers two rooms that are ideal for storing small everyday items, keys, wallet, phones, etc.

The two rooms are perfectly suited for our large drawers which fit perfectly in the two compartments.





## ACCESSORIES BOOKCASES

# RATTAN

Rattan is a decorative natural material that adds a warm, tactile touch to an interior. When it is used as a door in the bookcase, the combination of wood and rattan creates a very appealing aesthetic expression.

Rattan is a beautiful natural material with sensuous associations to breezy summer days and exotic traditional crafts. The wickerwork also discreetly hides the content behind the door.



# FRAME

Frame creates new possibilities for your ATBO bookcase by raising it from the floor and giving it a more contemporary expression. Frame is a modernist frame around a classic cube that, besides adding a more dynamic aesthetic to the bookcase, provides a shelving unit that does not have to be wall-mounted.

Choose a steel frame to contrast the wood of the bookcase, or choose Frame in the same solid wood material as the bookcase for a coherent expression.

## DIMENSIONS AND MATERIALS

FRAME IS AVAILABLE IN BLACK PAINTED STEEL AND SOLID WOOD: BEECH, OAK, ASH, MAHOGANY AND WALNUT.

FRAME DEPTH 30/34.5

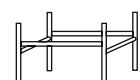

H20 X W35.6



H20 X W70

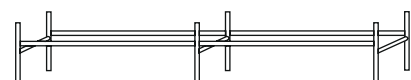

H20 X W140



# MARBLE TOP

Marble Top is a new way to update your bookcase that gives the top surface a central functional role. A space to keep things. A space to display things. A space for calm.

Marble Top adds character to the ATBO bookcase and transforms it into a console table that offers new expressive and functional possibilities.

Marble Top adds character to ATBO's bedside and the opportunity of coffee or tea close to the bed.



# GLASS KNOBS

The Glass Knobs are handcrafted and designed by Nina Nørgaard for ATBO bookcases.

The Glass Knobs are sculpted in Denmark with the deepest care for every object. When handcrafting every piece, the result will slightly differ and is therefore individually unique.

The Glass Knobs are available in three different shapes and colors:

Shapes: Swirl, Tulip, Ripple

Colors: Sunflower, Soft Rose and Mint



BOOKCASE DEPTH 21/30/34,5

..... Moveable shelf

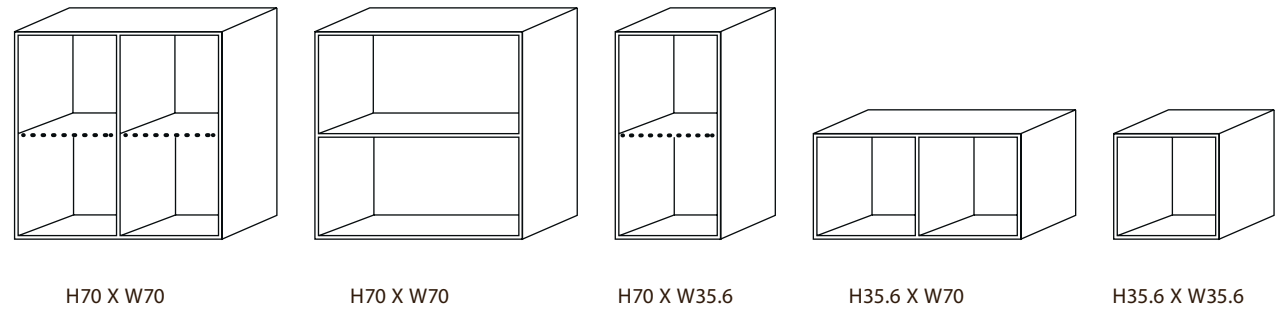

\* Only depth 21/30  
\*\* Only depth 34.5

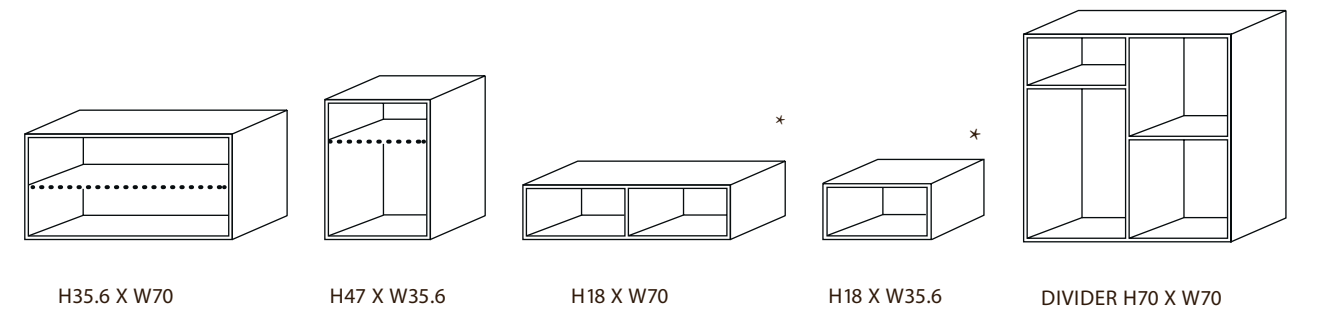

DOOR H67,4 X W33

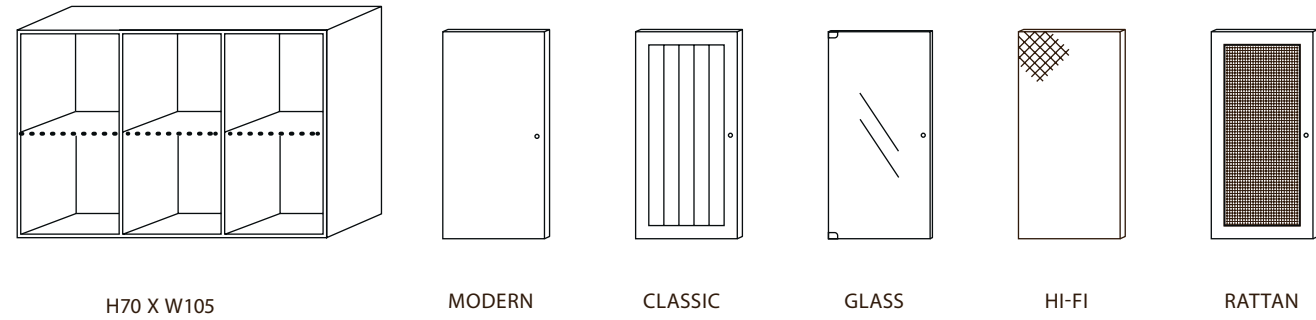

DOOR H33 X W33

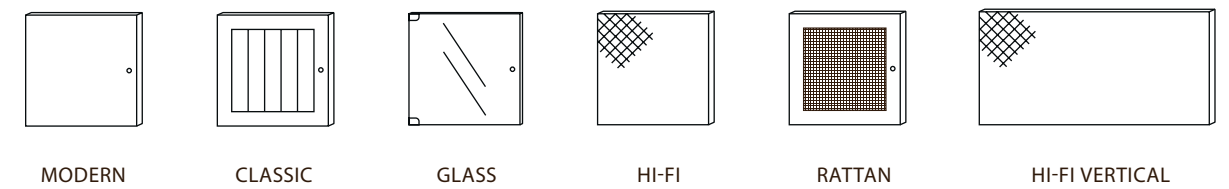

SHELF DEPTH 30/34.5

SHELF DEPTH 30/34.5

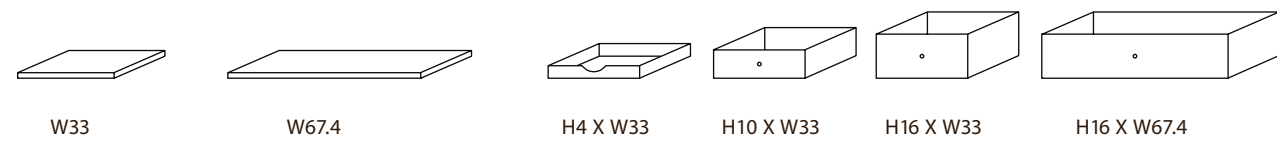

MARBLE TOP PLATE BIANCO / GRIGIO / NERO DEPTH 30/34.5

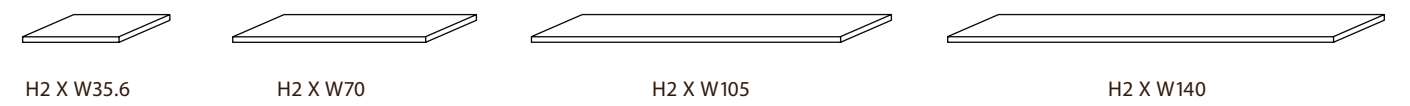

FRAME DEPTH 30/34.5

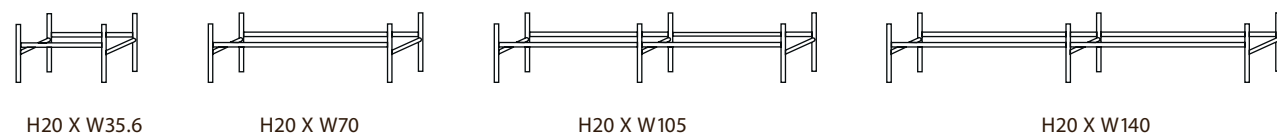

BASE OPTIONS DEPTH 30/34.5



**BAMBOO**

Bamboo is not actually a wood type but a fast-growing type of grass that has an extreme capacity to absorb CO2. It undergoes a lengthy process where the bamboo is cut up, dried, glued together and compressed into a strong cross-fibre sheet. The bamboo slats mutually support each other to make a strong, sustainable and stable material that reflects the skill and craftsmanship that went into its making and has a beautiful graphic expression.

**MAHOGANY**

Deep and dark. Exotic and exclusive. Light and lively. Mahogany has always been a high-end, elegant wood type. Our mahogany is sourced from Africa and has a deep, reddish-brown tone with a unique play of colours. Mahogany is often used for musical instruments, where it brings a warm, round, rich sound. Design history contains many examples of mahogany furniture by iconic cabinetmakers, including the renowned Kaare Klint.

**ASH**

Ash is hard and heavy and has excellent properties for bending. In prehistoric times it was used for carts, ladders and spears, among other purposes. Ash is our lightest-coloured wood type with a delicate and beautiful expression that really comes into its own when the bookcases are placed side by side, so that the light colours complement and add depth to each other. Ash is also available in a black-stained version where the grain is subtly visible and brings a structured and warm look to the black finish.

**BEECH**

The beech is widely considered Denmark's national tree, and the Danish word for beech is one of the oldest in our language. It has a more yellow tone than ash and oak but shares many of the same properties. Beech is hard and strong, and the structure appears highly uniform with fine pores and widely spaced annual rings. Beech trees can be harvested when they are around 30 years old, but many are not felled until they are between 90 and 120 years.

**OAK**

Oak can have a lifespan of up to 100–150 years before they are felled. Like ash, oak is a heavy and hard wood type with good properties for bending. It has a warm, golden glow and a delicate grain that makes it a popular material for furniture making. Oak has historically been used for buildings, bridges and roof constructions, and due to its high content of tannins it also has good properties for curing leather and aging wine.

**WALNUT**

Walnut ranges in colour from greyish tones to deep dark brown. It is a hard and strong wood type, and the American walnut trees we use can grow to a height of 40 metres with a diameter of one metre. Walnut is an exclusive wood type, as hand-sorting is necessary because the colour can range from very light to very dark, but it offers an inimitable expression.

**WOOD LIBRARY**

Wood is a living material, so no two bookcases are ever completely alike. Subtle variations in grain and colour highlight the natural character of the material and are an essential source of the expression and charm of the bookcases. The ATBO bookcases are made in five solid wood variants and in bamboo and birch veneer. Our ash, oak and beech wood is sourced in Europe, while the walnut, bamboo and mahogany come from North America, China and Africa.

**CERTIFIED**

All our wood is certified, which means that the forest management conforms to a responsible and global agenda that cares for trees and people all over the planet. Under practices, foresters never cut more trees than the forest can regenerate. Certification also ensures that forest workers have proper working conditions, terms and pay, and that local communities benefit socially and economically.

# DESIGNERS



PALLE SUENSON

Designer of THE PS38 LAMP

*Danish architect inspired by functionalism, educated from the Royal Danish Academy of Fine Arts in 1923. Founded his own architectural practice in 1930. Professor of Architecture (1941-71) and Rector of the Royal Danish Academy of Fine Arts in Copenhagen (1956-65). Throughout most of his oeuvre Palle Suenson contributed to danish urban architecture with his many iconic buildings influenced by modernism in addition to accomplishing prize winning restoration projects.*

Photo Credit; Connie Eriksen  
Christian Ejlers Forlag, København 1987, ISBN 8772415193



GUBI OLSEN

Designer of THE GUBI COLLECTION

*Danish designer born in Copenhagen. Educated at 'The Permanent Exhibition of Danish Craft and Arts'. Founded the furniture company GUBI in 1967 with his wife Lisbeth Olsen.*

*Gubi Olsen has pushed the boundaries of new designs by moving in new, uncharted territory. His global outlook is inspired by traditional craftsmanship and historical references, such as Napoleon Bonaparte, a grand piano and French cinema.*



PER BUCHARDT

Designer of THE CLOUD TABLE

*Per Buchardt graduated as an architect from the Royal Danish Academy of Fine Arts in 1993 and has had his own architectural practice ever since. In 2015 he founded the architectural firm Albjerg & Buchardt Arkitekter.*

*The firm takes on a broad range of projects, including newbuilds as well as transformation and restoration of listed buildings besides architecture and interiors for cultural, commercial, and residential purposes.*



NICOLINE OLSEN

Designer of THE CLOUD TABLE

*Nicoline Olsen has a background as a fine artist and has studied art history and languages.*

*The past 25 years she has been working as an independent journalist, stylist and photographer. She has written and photographed several books and has worked with international magazines producing editorial interior, food and lifestyle features. Recently, Nicoline has created concepts for trade fairs and strategy and consulting for brands including graphics work, websites and photography.*



# DESIGNERS



KEVIN HVIID

Designer of THE COCOON DINING,  
COCOON LOUNGE CHAIR  
and FRAME for bookcases

*The driving force of Danish born Kevin Hviid's work is an experimenting passion for architectural design, a playful approach towards form and a fondness for the unexpected. Through interdisciplinary projects, he uses creativity as a tool for innovation and change, questioning deep-rooted traditions, creating space for new ways of thinking, and acting. Kevin Hviid graduated from the Royal Danish academy of fine arts, School of architecture, Copenhagen, Denmark.*



MARTIN KECHAYAS

Designer of THE COCOON LOUNGE CHAIR

*Furniture and design are in constant interaction with our daily lives, when we sit, stand, or lie down. This interaction is the foundation for Martin's vantage point. Form, function and price are controlling factors in his design process and in that order. The form comes first and then the function gives the constraints that the form must adhere to. As a designer Martin aspires to create furniture that can withstand daily usage while patinating beautifully allowing it to be passed down through generations. Martin has studied at the Royal College of Design in Copenhagen.*



NINA NØRGAARD

Designer of THE GLASS KNOBS

*Nina Nørgaard is a Copenhagen based artist and designer working with glass. After studying mouth blown and structured glass with masters in Paris, Venice and San Francisco, she graduated from Kostra School of Glass in Sweden in 2010. Nina Nørgaard works with commissioned and personal projects worldwide. All the glassware designed by Nina Nørgaard is handcrafted and sculptured in Denmark with the deepest care of every object.*

*Photo Credit; Elizabeth Heltoft*

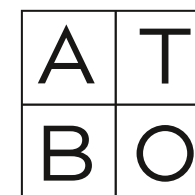

since 1967

## CONTACT

ATBO

T +45 3315 6601

[WWW.ATBO.COM](http://WWW.ATBO.COM)

[INFO@ATBO.COM](mailto:INFO@ATBO.COM)  
[SALES@ATBO.COM](mailto:SALES@ATBO.COM)

OWNER AND CEO  
PETER MONDRUP  
[PMO@ATBO.COM](mailto:PMO@ATBO.COM)  
T +45 2035 1781

SALES  
BRIAN MORTENSEN  
[BMO@ATBO.COM](mailto:BMO@ATBO.COM)  
T +45 8180 2841

CONCEPT AND PRODUCTION BY **APPEAL MAGAZINE**  
[WWW.APPEALMAGAZINE.LIVE](http://WWW.APPEALMAGAZINE.LIVE) @APPEALMAGAZINE.LIVE



1967-2023