

Spreader Beam

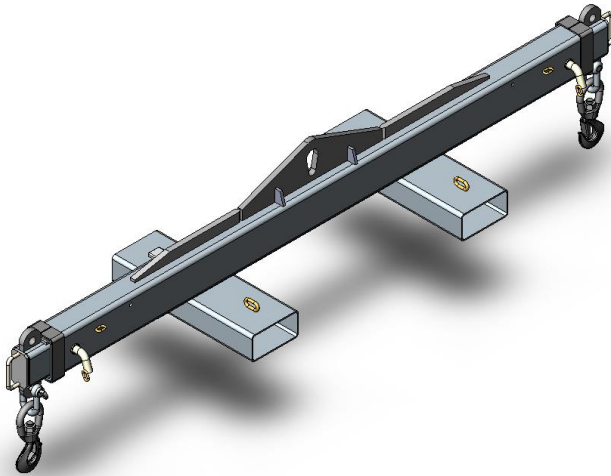

The type CFL-2439 Spreader Beam is a unique multi-tasking Beam which can be used by Crane or Forklift to lift long loads. Using a Crane, loads can be lifted via the centre single hook point (as a 'Lifting Beam'), or end lifted using a 2 leg Chain Sling (as a 'Spreader Beam'). If lifting by forklift, the 600mm long slipper pockets allow for fast and safe connection to the truck.

The Spreader Beam load connection points are adjustable to 3 positions by moving the extendable arms each end. Both extendable arms are locked into position via safety pins. The unit is supplied standard with a safety swivel hook each end.

The extendable arms are zinc plated with the main body painted in 'safety orange'.

The unit is fully 'Third Party' certified to relevant Australian Standards – Certification Certificate supplied upon request.

SPECIFICATIONS:

- Rated Capacity (RC Max.): 9000kg
- Load Centre (LC): 2405mm
- Unit Weight: 172kg
- F/Lift HCG: 300mm

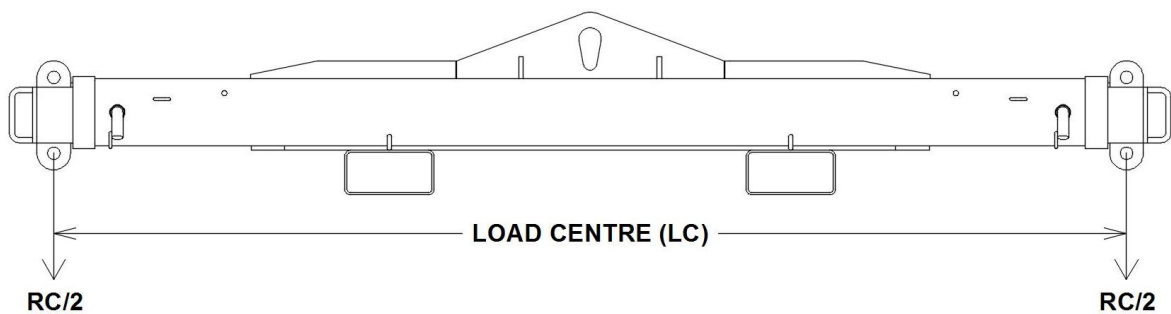

CFL-2439 LOAD CHART

RATED CAPACITY (RC) WHEN USED AS	FULLY RETRACTED (LC @ 2405mm)	MIDDLE POSITION (LC @ 3165mm)	FULLY EXTENDED (LC @ 3925mm)
FORKLIFT ATTACHMENT	3500KG	1500KG	750KG
LIFTING BEAM	4500KG	2500KG	1300KG
SPREADER BEAM	9000KG	7200KG	5600KG