

Thank you for purchasing the general purpose gasoline engine

This OPERATION MANUAL tells you how to operate and service your gasoline engine. Please read it before using the engine to insure proper handling and operating. Follow the instructions carefully to keep you engine in the best running condition.

This OPERATION MANUAL deals with the main points for operation of the engine. If you have any question concerning this manual, or any suggestion, please contact your nearest dealer.

WARNING:

- This general purpose gasoline engine is designed to give safe and dependable service provide that it is operated according to OPERATION MANUAL
- Read and understand to OPERATION MANUAL before operating the engine, failure to do so could result in personal injury or equipment damage.



Declaration of Conformity (Manufacturer's Declaration)



We: **Fuzhou Launtop M And E Co., Ltd.**
Jinshan Industrial Park, Fuzhou, Fujian 350002, P. R. China

declare in sole responsibility that the equipment

air cooled gasoline engine

LT87,LT160,LT200,LT210,LT240,LT270,LT340,LT390,LT420

S/N: see marking on engine

to which this declaration applies, complies with the following directives and/or standards:

*2006/42/EC
2004/108/EC*

The products must not be put into service until the final machinery into which it is to be incorporated has been declared in conformity with the provision of applicable directive.

Notes:

This declaration becomes invalid, if technical or operational modifications are introduced without the manufacturers consent.

Person responsible for keep the technical file:

Name, Surname: FENG LIU

Address: Z.I BELLEVUE 35220 CHATEAUBOURG FRANCE

Person responsible for making this declaration:

Name and Signature: 

Date and Place: 31-JAN-2011, FUZHOU, CHINA

The title of signature: Marketing Director

CONTENTS

1. SAFE TIPS.....	1
2. SPECIFICATIONS AND PARTS DESCRIPTION.....	2
3. FUEL AND ENGINE OIL.....	4
4. PRE-OPERATION INSPECTION.....	6
5. STARTING AND STOPPING THE ENGINE.....	7
6. INSPECTION AND MAINTENANCE.....	10
7. STORAGE OF ENGINE	13
8. TROUBLE SHOOTING.....	13

1. SAFE TIPS

WARNING:

These items that are very important for safety. Please be sure to obey them.

- Do not allow people who do not understand this OPERATION MANUAL to operate the engine.
- Do not run the engine indoors or where ventilation is poor.
- Keep explosive and flammables at least 1 m (3ft) away from the engine.
- Do not smoke when adding fuel
- Do not run the engine when gasoline has split, clean the overflowing fuel and fuel spillage.
- Do not remove the fuel tank cap or add fuel while the engine is running or hot.
(Add fuel after the engine has cooled by waiting 2 or more minutes after engine is stopped.)
- Do not run the engine without the muffle or air cleaner remove.
- Do not touch the muffle, muffle cover or engine body while the engine is running or hot.
- Place the protective covers over the rotating parts. If rotating parts, such as the drive shaft, pulley, belt, etc, are exposed, they are potentially hazardous. To prevent injury, equip them with protective covers or shrouds.
- Be careful of hot parts. The muffler and other engine parts become very hot while the engine is running or just after it has stopped. Protective measures must be provided in the specific application.



2. SPECIFICATIONS AND PARTS DESCRIPTION

2-1. Specifications

Model	LT87	LT160	LT200	LT210	LT240	LT270	LT340	LT390	LT420	
Type	Single-cylinder, 4-stroke, OHV, air-cooling gasoline									
Displacement	cc.	87	163	196	208	242	270	337	389	420
Bore x Stroke	mm	54×38	68×45	68×54	70×54	73×58	77×58	82×64	88×64	90×66
Compress ratio		7.8:1	8.5:1	8.5:1	8.5:1	8.2:1	8.2:1	8.0:1	8.0:1	8.0:1
Speed	rpm	3600								
Continuous Output	kW/hp	1.65/2.2	3.17/4.3	3.66/5.0	4.0/5.5	4.6/6.3	5.29/7.2	6.3/8.6	7.35/10	8.0/11
Max.torque	N.m/rpm	5/2500	10/2500	11/2500	12/2500	14.5/2500	16.5/2500	20/2500	22.5/2500	24.5/2500
PTO direction	Counter-clockwise(view to PTO side)									
Strating system	Recoil	Recoil/Electric								
Ignition system	T.C.I.(Transistorized magneto ignition)									
Lub.Oil capacity	L	0.4	0.6			1.1	1.4			
Fuel tank capacity	L	1.7	3.6			6				
Dimensions (L×W×H)	mm	286×305×285	315×362×335			380×430×410		405×450×435		
Dry weight	kg	10	14	16	16	25	25	31	31	31

2-2. Parts Description

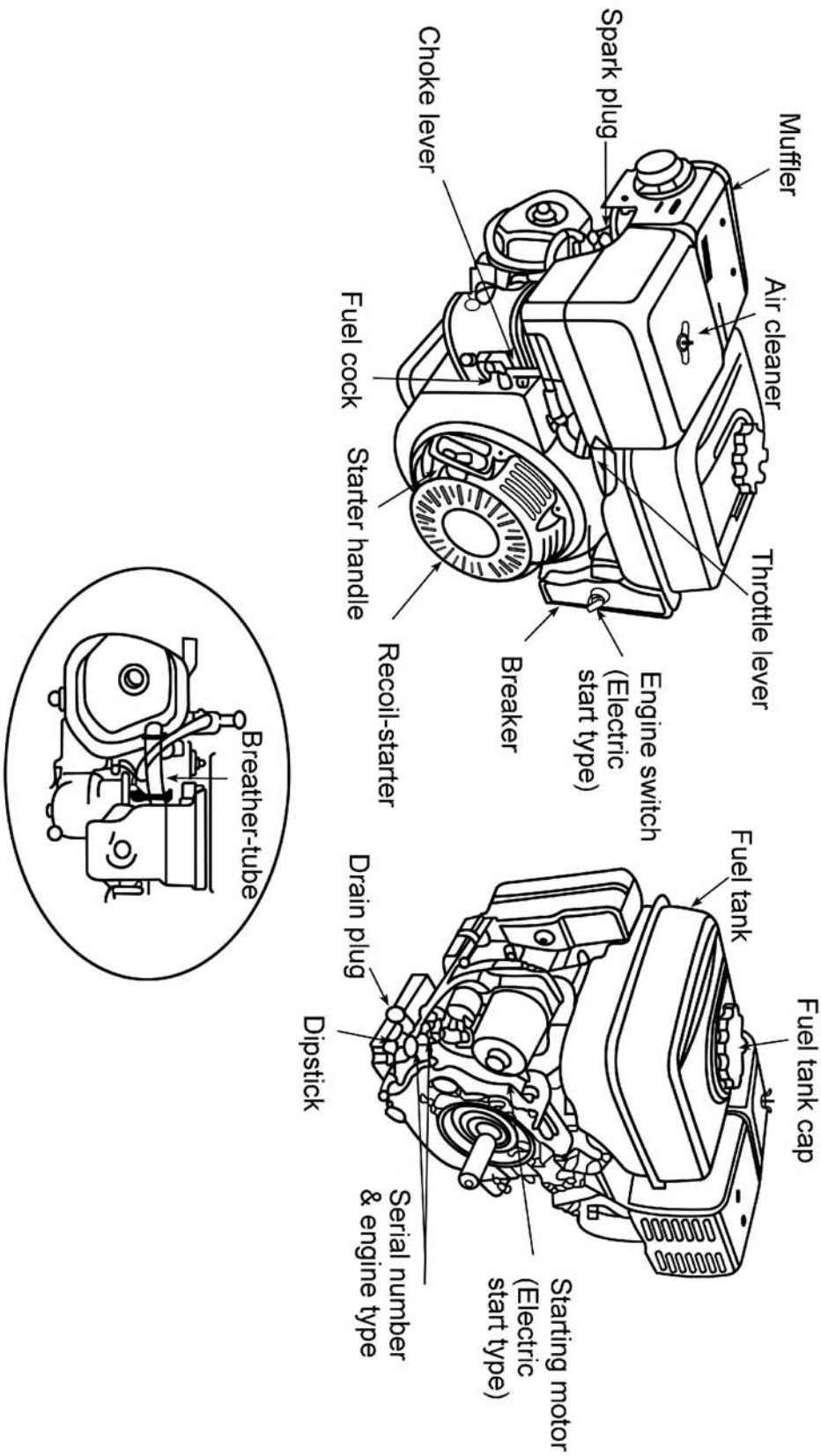

3. FUEL AND ENGINE OIL

3-1. Fuel

- Use clean, fresh, unleaded gasoline.
- Do not mix oil into the gasoline
- Do not overflow the gasoline when filling the fuel tank

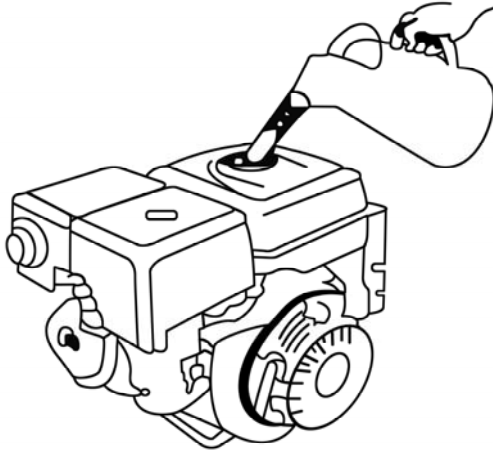

Fuel upper level

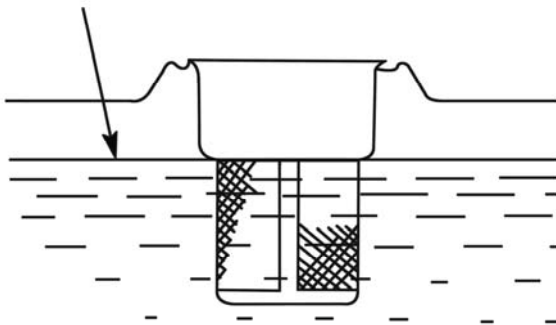

WARNING:

- Flame and heat can cause gasoline to explode. Be sufficiently careful of flame and heat when handle gasoline.

3-2. Engine Oil

- Use the engine oil following the table below

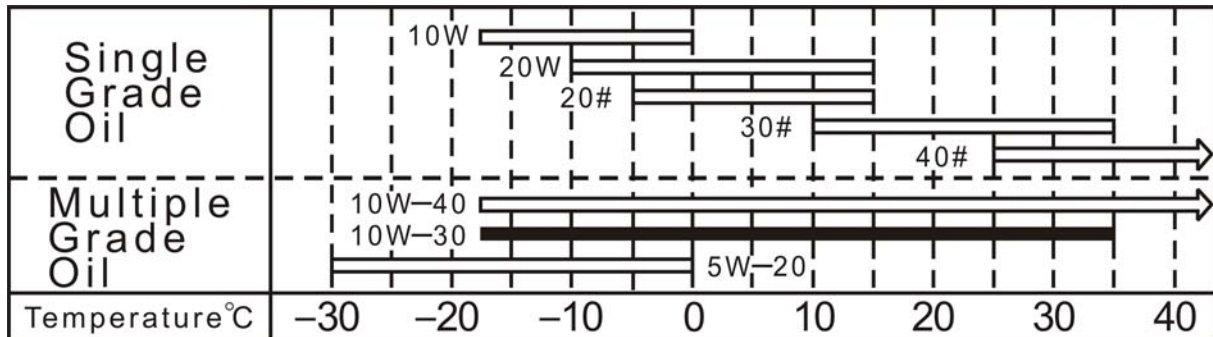

Note: Recommended engine oil: SAE 15W-40 mineral oil use only

- Do not add commercial additives to the oil.
- Do not mix gasoline into the oil

WARNING:

Engine is shipped without oil. Before starting, be sure to conduct an oil inspection by following instructions given

Place the engine on a level surface when adding oil and conducting inspections;

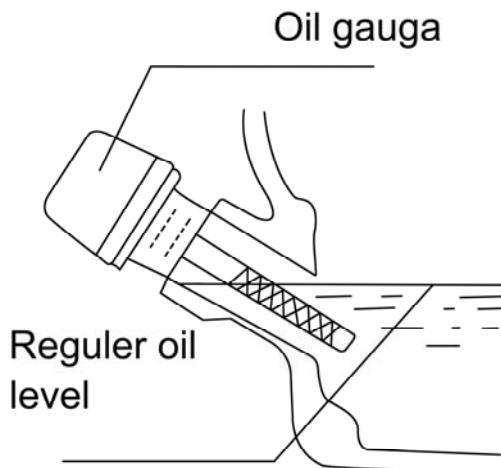

- ② Check the oil level without the oil gauge screw in;
- ③ Fill the oil up to level of oil gauge;
- ④ Before starting the engine ,tightly screw in the oil gauge.

4. PRE-OPERATION INSPECTION

4-1. Fuel Inspection



- Is there gasoline in the tank?
- Is old gasoline being used?
- Is the fuel tank cap closed correctly?

WARNING:

Be sufficiently careful of heat and flame when handling the fuel. Not doing so could cause fire or explosion

4-2. Air-cleaner Inspection

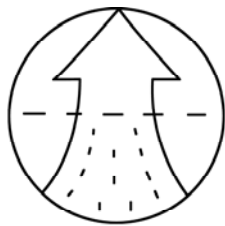

- Is the air-cleaner element dirty?
- When the air-cleaner element is dirty ,cleaning it.

4-3. Engine Oil Inspection

- Is the engine filled with the recommended engine oil, and is the oil dirty?
- If there is not enough oil, if it is dirty, or it has been used long than the specified time, adding or changing the engine oil.



4-4. Inspection the Tightness of all Fastener Screw

- Are all the screw tight?
- Be sure to check the screw used to fasten the muffler (Do this when the muffler is cold)

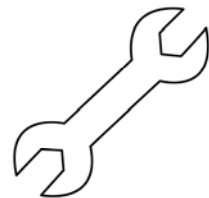

4-5. Fuel and Oil Leaks Inspection

- Are there any fuel or oil leaks? If any are found have a repair



5. STARTING AND STOPPING THE ENGINE

5-1. Starting the Engine

WARNING:

Before starting the engine, carefully read and understand the "SAFE TIPS" and "PRE-OPERATION INSPECTION" section of this OPERATION MANUAL.

① OPEN the fuel cock

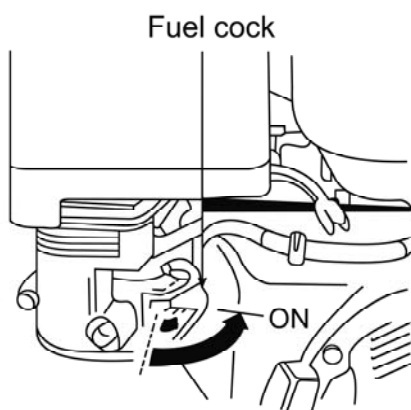

② Turn the engine switch to "ON" position

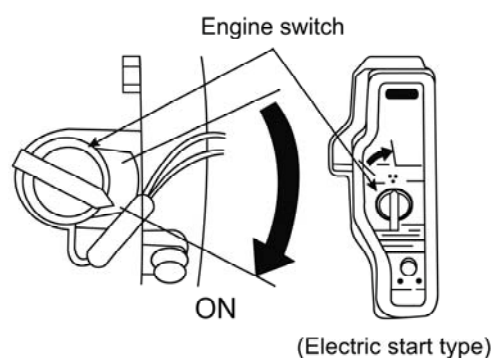

③ Complete CLOSE the choke valve

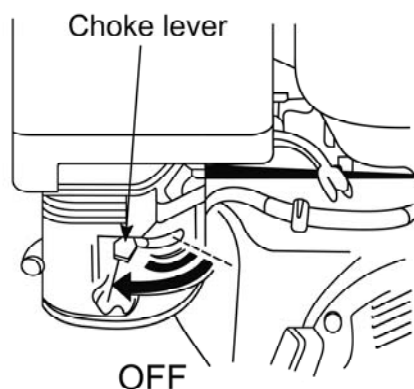

④ Move the throttle lever a little to OPEN

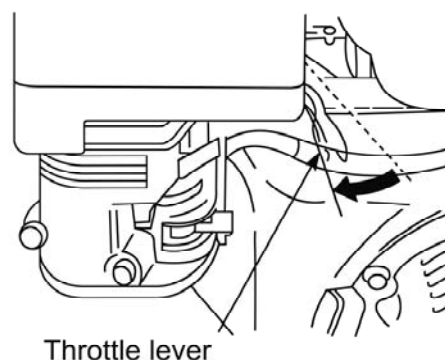

⑤ start the engine as follow

a. Recoil start:

- Hold the starter handle and pull it slightly until the compression position is reached, and then pull it swiftly from this position;
- Slowly return the starter handle to its original position after the engine starts.

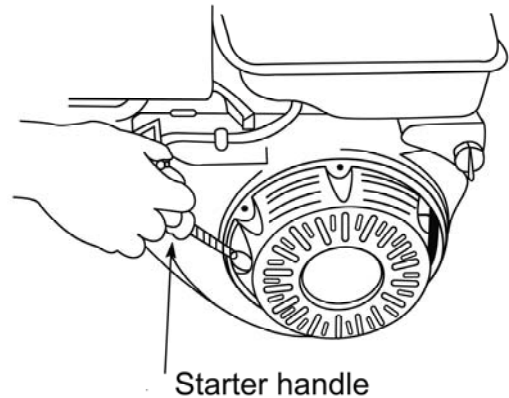

b. Electric start;

- Turn the key switch to "START" position; and remain it until the engine starts.
- If engine dose not starts after running of the electric starter for 5sec., wait 10sec. before next trying
- After engine starts, please release the key switch, it will return to "ON"(or "RUN") position.



Engine switch
(Electric start type)

⑥ After engine starts, gradually turn the choke lever to the full "OPEN" position, and set the throttle lever in the Max. position. Before loading, warm up the engine for about 3 min.

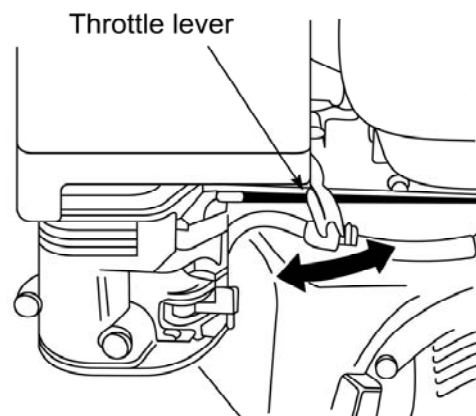
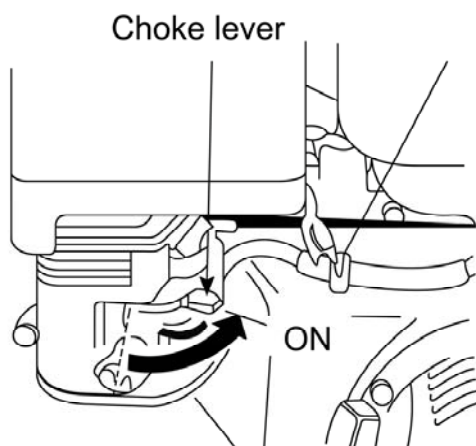

5-2. Stop the Engine

- ① Move the throttle lever to "CLOSE" position;

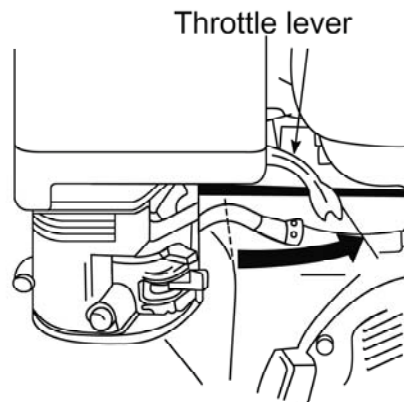

- ② Turn the engine switch to "OFF" position;

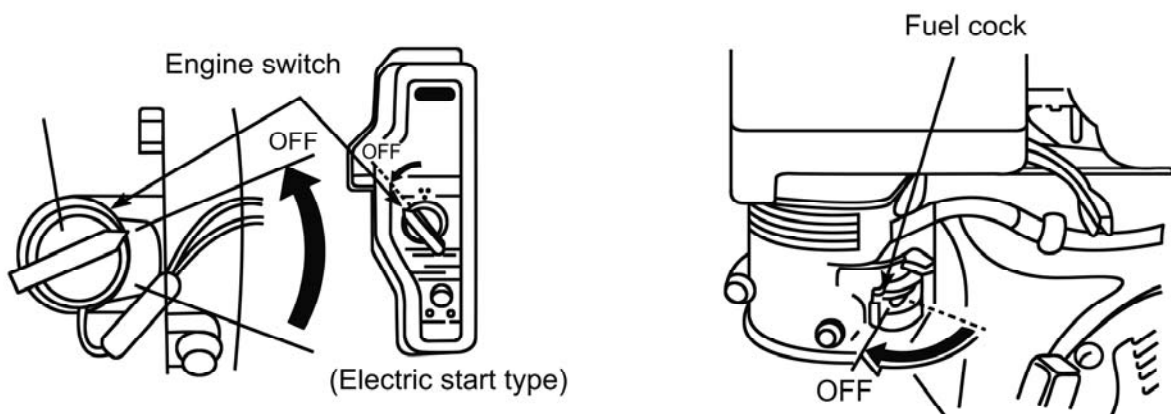

- ③ Close the fuel cock

NOTE:

- In emergency, turn the engine switch to "OFF" to stop the engine.

WARNING:

- Never stopping the engine at high speed under heavy load, otherwise, the damage will result.

6. INSPECTION AND MAINTENANCE

6-1. Daily and Regular Inspection

WARNING:

- Daily and regular inspections is important to assure safe, proper and long-term operation of the engine. Refer to the regular inspection table when conducting inspections and maintenance.

Regular Inspection Table:

Item	Time	Every operation	Every 25 hours	Every 50 hours	Every 100 hours
Inspection and tightening of bolt and nut at each place		○			
Engine oil level check and supply		○			
Change of engine oil			● only the first time	○	
Check for fuel and oil leaks		○			
Check and cleaning the air cleaner		○			
Check and cleaning of spark plug				○	
Check and cleaning of fuel strainer				○	
Remove of carbon in combustion chamber					◎
Check and adjustment of valve clearance					◎
Replace the fuel lines		2 years (or when necessary)			

Noted: Item marked with a ○ require advanced skill and tools, so they should be done by the specify person.

6-2. Parts Maintenance

① Cleaning the air cleaner

- Loosen the wing-nut and remove the air cleaner cap;

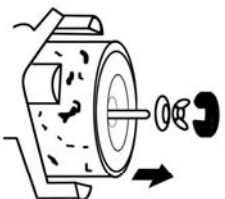
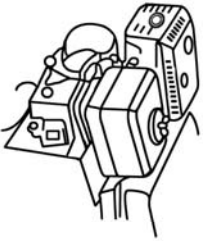

- Loosen the wing-nut and washerremove the element;

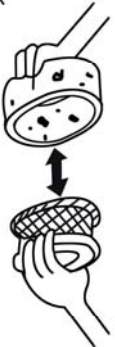

- Separate the primary and secondary element;

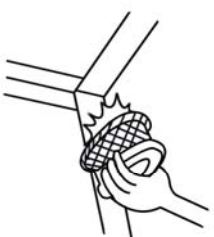

- Tap the element or use compress air to blow from inside;

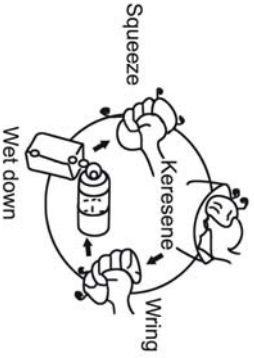

- Reassembly the air cleaner.



② Cleaning the spark plug

- Remove the carbon attached to the electrode;
- Polish the electrode with emery paper or wire brush;
- Adjust the electrode gap.

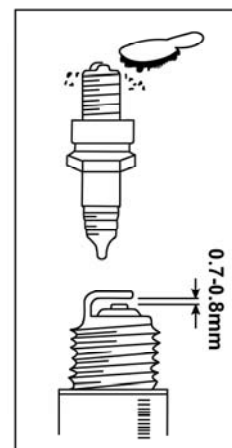
**③ Cleaning the fuel filter**

- Remove the filter from fuel tank;
- Cleaning it in solvent
- Wipe off;
- Replace the filter into fuel tank

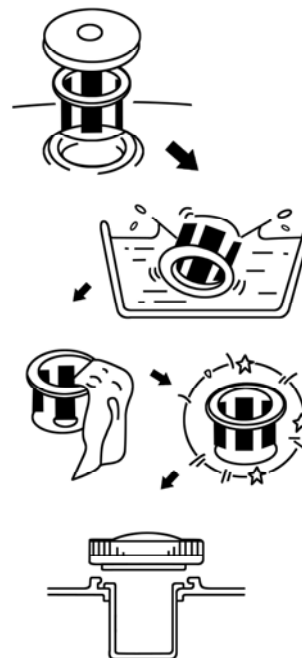
**④ Cleaning the deposit cup of fuel cock**

- Remove the cup from fuel cock;
- Cleaning the cup;
- Replace the cup use a new O-ring.



7. STORAGE OF ENGINE

Should the engine be stored for a long period, please do as follows:

- ① Drain off the fuel in tank and oil in crankcase;
- ② Remove the spark plug, add about 2-3 cc. Engine oil into the cylinder, and reinstall the spark plug. Pull the recoil until feeling the compression. At this time, both the inlet and exhaust valve are close to prevent the engine chamber from rusting;
- ③ Clean the surface of engine with clean cotton;
- ④ Store the engine in dry and dust free area.
- ⑤ Electric starter: Disconnect the battery, change the battery once every month.

8. TROUBLE SHOOTING

Starting failure:

- ① Is ignition normal?
 - Is engine switch turn to "ON" position?
 - Remove the spark plug, when it is soiled, clean or replace it.
- ② Is compression sufficient?
 - Confirm 6x pulling the starter handle slowly. When compression is insufficient, check whether tightening of spark plug is firm. If it is loose, tighten.
- ③ Is fuel sucked into the combustion chamber?
 - Is fuel cock open?
 - Close choke lever, pull the starter handle several times ,then remove the spark plug. When the tip of spark plug is wet, it is OK.
 - When fuel is not sucked, check fuel strainer for clogging.
 - When engine does not start though fuel is sucked, replace fuel with new.

When the engine does not start in spite of above mentioned inspections, ask the distributor or repair factory for inspection.