

Snipe Nose Side Cutting Pliers

Radio Pliers, DIN ISO 5745

25

- > suitable for fine gripping and cutting work
- > pointed, half-round jaws
- > serrated gripping surfaces
- > cutting edges for soft, medium hard and hard wire
- > cutting edges induction hardened, cutting edge hardness (approx. 61 HRC)
- > vanadium steel; forged, multi-stage oil-hardened

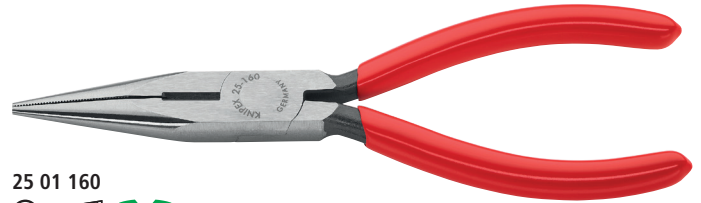
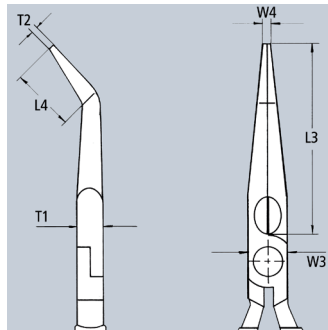
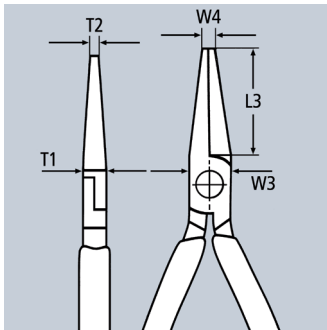

25 01 160



25 02 160



25 08 160 SBA

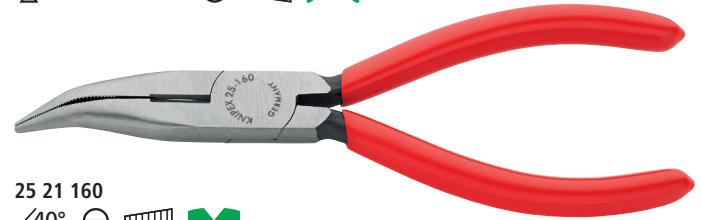

25 21 160



Product Number	Packaging	↔ Inch mm		Pliers	Head	Handles	Cutting capacities		Dimensions						⚖ lbs
							● Ø Inch Ø mm	● Ø Inch Ø mm	L3 Inch mm	L4 Inch mm	W3 Inch mm	T1 Inch mm	W4 Inch mm	T2 Inch mm	
25 01 125		5 125					3/32 2.2	1/16 1.6	1 1/16 27.0	-	1/2 13.0	9/32 7.0	3/32 2.5	5/64 1.8	0.16
25 01 140		5 1/2 140	☉	black atramentized	polished	plastic coated	3/32 2.5	1/16 1.6	1 21/32 42.0	-	19/32 15.0	5/16 8.0	3/32 2.5	5/64 2.0	0.20
25 01 160	X	6 1/4 160					3/32 2.5	1/16 1.6	1 31/32 50.0	-	21/32 16.5	23/64 9.0	1/8 3.0	3/32 2.5	0.25
25 02 140	X	5 1/2 140	☉	black atramentized	polished	multi- component grips	3/32 2.5	1/16 1.6	1 21/32 42.0	-	19/32 15.0	5/16 8.0	3/32 2.5	5/64 2.0	0.24
25 02 160	X	6 1/4 160	☉	black atramentized	polished	multi- component grips	3/32 2.5	1/16 1.6	1 31/32 50.0	-	21/32 16.5	23/64 9.0	1/8 3.0	3/32 2.5	0.32
25 08 160 SBA	X	6 1/4 160	⚡ 1000 V ASTM ☉	black atramentized	polished	insulated, multi- component grips, ASTM-tested	3/32 2.5	1/16 1.6	1 31/32 50.0	-	21/32 16.5	23/64 9.0	1/8 3.0	3/32 2.5	0.34
25 21 160	X	6 1/4 160	∠40° ☉	black atramentized	polished	plastic coated	3/32 2.5	1/16 1.6	1 31/32 50.0	29/32 23.0	21/32 16.5	23/64 9.0	1/8 3.0	3/32 2.5	0.25