

TRIMINATOR[®]
XL DRY

OWNER'S MANUAL_{v1}

CONTENTS

INTRODUCTION	2
SAFETY MESSAGES	2
TRIMMER SAFETY	3
IMPORTANT SAFETY INFORMATION	3
SAFETY LABEL LOCATIONS	4
SETTING-UP YOUR NEW TRIMMER.....	5
CONTROLS AND COMPONENTS.....	6
OPERATION	8
STARTING THE TRIMMER.....	9
TRIMMING PLANT MATERIAL.....	10
TRIMMING TIPS	11
MAINTENANCE SAFETY	12
DISASSEMBLE FOR CLEANING AND SERVICE.....	13
CLEANING AND REASSEMBLY	15
TAKING CARE OF UNEXPECTED PROBLEMS.....	17
CUSTOMER SERVICE	18
LIMITED WARRANTY	19
EXCLUSIONS FROM WARRANTY COVERAGE.....	20

INTRODUCTION

Congratulations on your selection of the Trinator commercial leaf trimmer! We want to help you to get the best results from your new trimmer and to operate it safely. This manual contains the information on how to do that; please read it carefully before you set up and use your trimmer.

We suggest you read the LIMITED WARRANTY (page 19) to fully understand coverage and your responsibilities of ownership. Keep this owner's manual handy, so you can refer to it at any time. This owner's manual is considered a permanent part of the trimmer and should remain with the trimmer if resold. The information and specifications included in this publication are those that were in effect at the time of approval for printing. Mosman Machinery Company, Inc. reserves the right, however, to discontinue or change specifications or design at any time without notice and without incurring any obligation whatever. No part of this publication may be reproduced without written permission.

SAFETY MESSAGES

Your safety and the safety of others are very important. We have provided important safety messages in this manual and on the Trinator. This information alerts you to potential hazards that could hurt you or others. Please read these messages carefully. Of course, it is not practical or possible to warn you about all the hazards associated with operating or maintaining a trimmer. You must use your own good judgment.

You will find important safety information in a variety of forms:

Safety Labels - located on the trimmer.

Instructions - how to use this trimmer correctly and safely.

Safety Messages - preceded by a safety alert.

A symbol and one of two signal words: **DANGER**, **CAUTION**. These signal words mean:



You WILL be KILLED or SERIOUSLY HURT if you don't follow instructions.



You CAN be KILLED or SERIOUSLY HURT if you don't follow instructions.

Each message tells you what the hazard is, what can happen, and what you can do to avoid injury.

Damage Prevention Messages - You will also see other important messages that are preceded by the word **NOTICE**. This word means:



Your trimmer or other property can be damaged if you don't follow instructions.

TRIMMER SAFETY

IMPORTANT SAFETY INFORMATION

Triminator commercial trimmers are designed to trim excess plant material from a variety of herbal material. Other uses could result in injury to the operator or damage to the trimmer and other property. Injuries and property damage from trimmers can be prevented by following all instructions in this manual and on the trimmer. The most common hazards are discussed below, along with the best way to protect yourself and others.

Avoid Rotating Slotted Drum

The Trinator's slotted drum can cause serious damage, cuts and even amputate fingers or hands. Keep hands, arms, and body away from the slotted drum whenever the drum drive motor is running. Keep hair, clothing, and jewelry away from the drum. If you need to work around the trimmer to clear or clean plant material for any reason, always shut off the electric motor and disconnect the trimmer's power cord from the AC outlet. Use a wooden stick to remove any obstruction or debris. ***Never put your hand into the slotted drum while the machine is running; serious personal injury could result.***

Avoid Shear Band

The Trinator's shear band can cause serious cuts and even amputate fingers and hands. Keep the diamond plate covers, red name plate and clear end cap in place at all times while machine is operating. If you need to work around the trimmer to clear or clean plant material for any reason, always shut off the electric motors and disconnect the trimmer's power cord from the AC outlet.

Clear Operation Area

Before operating the trimmer, carefully inspect the surrounding area and remove all obvious hazards that could cause you to trip, slip, or fall into the trimmer.

Keep Guards and Shields in Place

Guards and shields are designed to protect you from touching moving components. For your safety and the safety of others, keep all shields in place when the trimmer is running.

Turn Electric Motor Off When Not Operating the Trimmer

If you need to leave the trimmer for any reason, always turn the electric motor off.

Operate on Flat Surface

To avoid overturning, only operate the trimmer on flat surfaces. Control the trimmer carefully when transporting it across uneven ground or slopes. Do not push the trimmer down or across steep slopes: the trimmer could overturn, causing injury to the operator or bystanders.

Operator Responsibility

Know how to stop the trimmer quickly in case of emergency. Understand the use of all trimmer controls. Never permit anyone to operate the trimmer without proper instruction. Do not let children operate the trimmer.

SAFETY LABEL LOCATIONS

The labels shown here contain important safety information. Please read them carefully. These labels are considered a permanent part of your trimmer. If a label comes off or becomes hard to read, promptly contact your authorized Triminor dealer for a replacement.

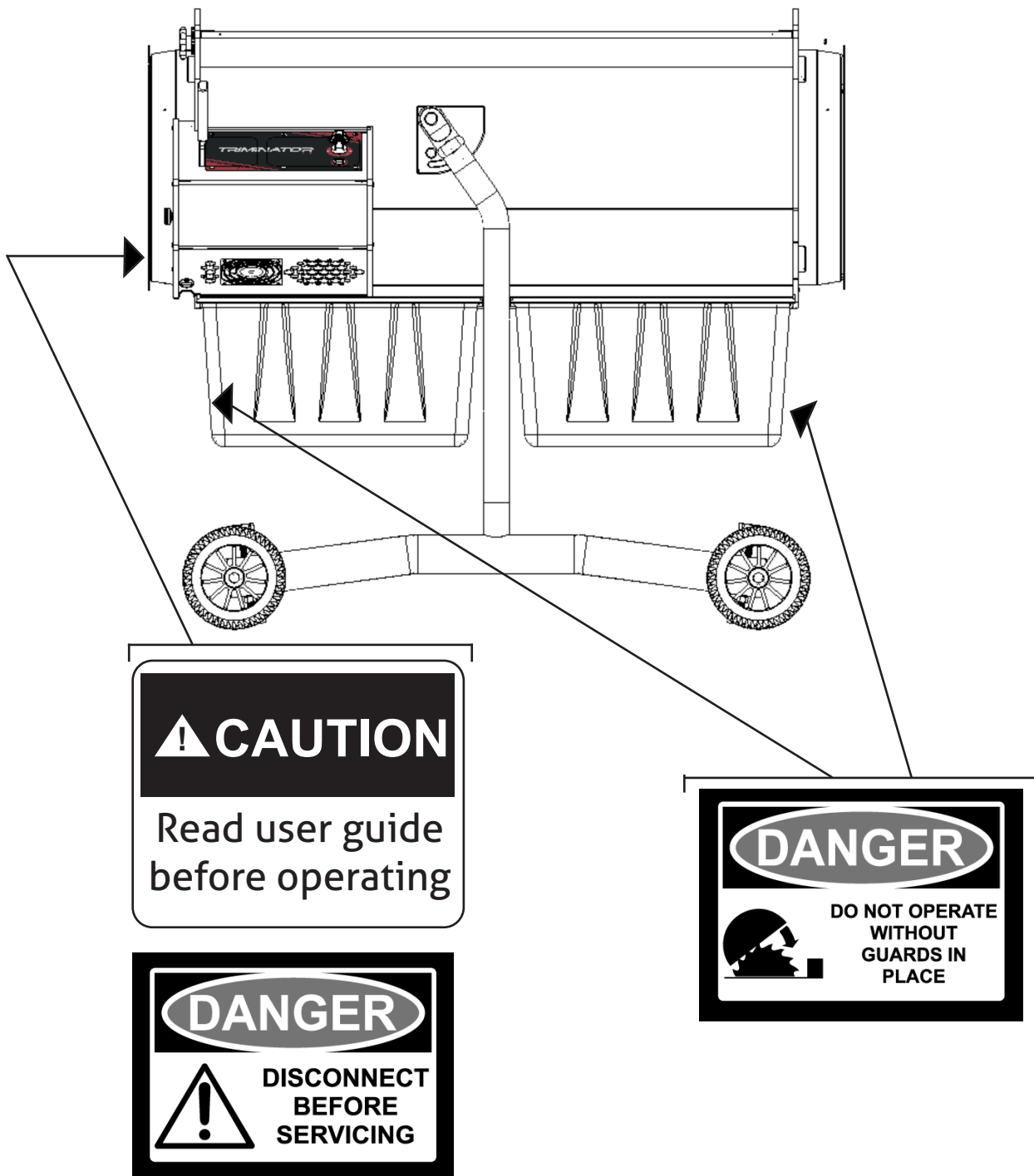

SETTING-UP YOUR NEW TRIMMER

UNPACKING and INSPECTION

Trinator XL Dry comes fully assembled in a shipping crate. Upon receipt please check the crate for damage and mark any damage on the shipping BOL and follow the shipper's instructions.

1. To begin, disassemble the shipping crate. Make note of any damage, which is identified on either the machine or the shipping crate. Notify the shipper, your dealer and MMC immediately, should damage be identified.
2. Remove the machine from the packaging and place it on a flat and level surface.
3. Turn the leveling screws, located near the wheels down and into position until the units wheels no longer touch the ground and the machine is in a level and stable position.

CONTROLS AND COMPONENTS

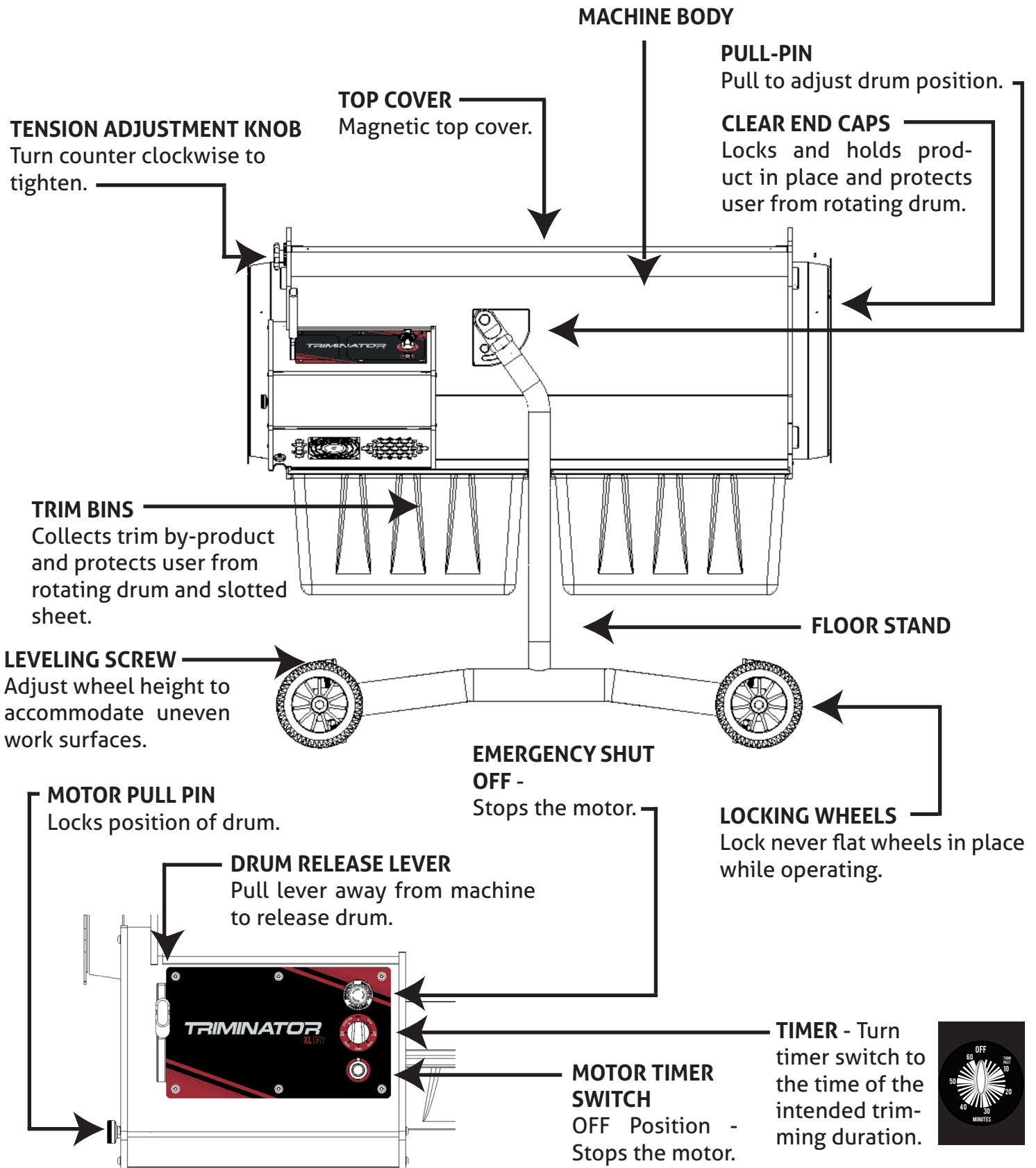

CONTROLS AND COMPONENTS (CONT)

BEFORE OPERATION

Read and understand this manual. Know what the controls do and how to operate them. Familiarize yourself with the trimmer and its operation before you begin using it. Know how to quickly shut off the machine in case of an emergency.

Your safety is your responsibility.

IS YOUR TRIMMER READY FOR OPERATION?

For your safety, and to maximize the service life of your equipment, it is very important to take a few moments each time before you operate the trimmer to check its condition. Be sure to take care of any problem you find before you operate the trimmer.

Improperly maintaining this trimmer, or failing to correct a problem before operation, could cause a malfunction which could cause you to be seriously injured. Always perform a pre-operation inspection before each operation, and correct any problem.

Before beginning your pre-operation checks, be sure the trimmer is on a level surface, the motor timer switch is in the OFF position, and all power cords are unplugged.

Check the General Condition of the Trimmer

Clean the slotted drum, shear band, and tension system. Look for signs of damage.

Check each control for proper operation.

Check parts for wear. Replace if necessary.

Check that all nuts, bolts, and clamps are tightened appropriately.

KEEP ALL SHIELDS AND COVERS IN PLACE WHILE OPERATING THE TRIMMER.

OPERATION

CHECK YOUR WORK AREA

For your safety and the safety of others, always inspect the area before operating the trimmer.

Objects: Anything which can be grabbed by the rotating slotted drum is a potential hazard to you and others. Look for hazards and remove them from the work area. Tie back loose clothing and long, loose hair. Remove any jewelry.

SAFE OPERATING PRECAUTIONS

Before operating the trimmer for the first time, please review both the TRIMMER SAFETY section (page 3) and the BEFORE OPERATION section (page 7).

Even if you have operated other trimmers, take time to become familiar with how the Triminators works.

Never tamper with or alter any of the controls or safety devices on the trimmer.

Do not operate on slopes.

Never operate Triminators while under the influence of drugs, alcohol or prescriptions, including over-the-counter cold/flu medications and allergy medications.

Protective clothing and eye and/or hearing protection should be worn during operation.

For your safety, do not operate while wearing loose-fitting clothing, jewelry, etc..

Long hair should be secured in a manner that keeps it away from mechanical parts.

Rotating machinery parts can entangle loose clothing, long hair or dangling jewelry resulting in serious injury or death.

STARTING THE TRIMMER

CONNECT POWER CORDS

1. Connect the Trimator XL Dry's power cord to a 10 amp 120 vac AC circuit. Do not connect and disconnect the power cord with wet hands. Do not operate in the rain.

NOTICE

The Trimator machine draws a max of 5 amps.

STARTING THE MACHINE

Turn the Trimator Dry motor timer switch clockwise until the switch is aligned with the desired trimming duration.

STOPPING THE MACHINE DURING NORMAL OPERATION

To stop the Trimator during normal operation, turn the motor switch to the OFF position.

STOPPING THE MACHINE DURING AN EMERGENCY

To stop the Trimator in an emergency, press the shut off button.

DISCONNECT POWER CORDS

Disconnect the trimmer's power cord.

NOTICE: Be sure to hold the plug when disconnecting the power cord from the electrical outlet. Do not disconnect by pulling on the power cord.

TRIMMING PLANT MATERIAL

LOAD

Remove clear end cap from rear of the drum. Pull out Pull-Pin and pivot drum into an angled loading position. Load dried, prepped, untrimmed plant material into the drum. For best efficiency run batches of similar material.

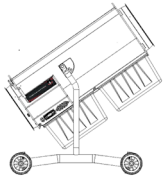

RUN

Pull out Pull-Pin and pivot Drum into a horizontal position. Turn machine ON and allow to run for 1-10 minutes. Check material every 1-3 minutes. For a closer trim, continue running the Triminators XL until desired trim is accomplished.



EMPTY

Empty Drum:

Once desired trim is accomplished, remove clear end cap on the motor end of the machine, position separate container (not included) to capture processed material, pull out Pull-Pin and pivot drum to a downward facing position. Processed material will be deposited in the container when correctly positioned.

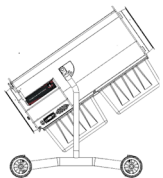

Empty Trim Bins:

Slide Trim Bins out of slots, empty Trim Bins and replace.

NOTICE: Trim Bins serve as a collection mechanism and a safety guard. Machine shall not be run without Trim Bins in place.

TRIMMING TIPS

For best efficiency, run batches of similar material through the machine. For a closer trim, run batches for longer durations until desired trim is accomplished.

REMOVING OBSTRUCTIONS

If the rotating slotted drum becomes restricted or clogged:

1. Stop the motor.
2. Make sure that all rotating parts have come to a complete stop.
3. Disconnect the trimmer's power cord.
4. Use a wooden stick to clear the obstruction.

SERVICING YOUR TRIMMER

Proper maintenance is essential for safe, economical, and trouble-free operation. To help you properly care for your trimmer, the following pages include a maintenance schedule. Other service tasks that are more difficult, or require special tools, are best handled by professionals and are normally performed by a Trinator technician or other qualified mechanic.

The maintenance schedule applies to normal operating conditions. If you operate your trimmer under severe conditions, such as sustained high-load or high-temperature operation, or use it in unusually wet or dusty conditions, consult your servicing dealer for recommendations applicable to your individual needs and use.

Remember that an authorized Trinator servicing dealer knows your trimmer best and is fully equipped to maintain and repair it. To ensure the best quality and reliability, use only new, Trinator Genuine parts or their equivalents for repair and replacement.

NOTICE: Improper maintenance, or failure to correct a problem before operation, can cause a malfunction in which you can be seriously hurt or killed. Always follow the inspection and maintenance recommendations and schedules in this owner's manual.

MAINTENANCE SAFETY

Some of the most important safety precautions follow. However, we cannot warn you of every conceivable hazard that can arise in performing maintenance. Only you can decide whether or not you should perform a given task. Failure to properly follow maintenance instructions and precautions can cause you to be seriously hurt or killed. Always follow the procedures and precautions in this owner's manual.

Safety Precautions

Make sure all motors are off and power cords are unplugged before you begin any maintenance or repairs.

Read the instructions before you begin, and make sure you have the tools and skills required.

MAINTENANCE SCHEDULE

INTERVAL	ITEM
Before each use	Check that shear band is snug, and in contact with slotted drum and is tightened appropriately (see pg 16) Check that machine is free of excessive debris. Ensure that machine is clean and the drum can be rotated without power under manual force.
During use	Although not required, application of a food grade lubricant can help reduce resin build up and keep slotted drum clean.
After each use	For best performance and longevity, clean trimmer after every use or if plant material is visibly affecting the trim quality or speed of the trimmer.
Every 10 hours of operation	For maximum wear life, rotate orientation of shear band every 10 hours or when visible signs of wear are identified. Although not required, this will extend the life of the shear band.
Every 80 hours of operation	Check the rubber drive wheel. To do this remove the drum and inspect the drive wheel (located on the outfeed side of the motor housing) for signs of wear, cracks or breaks. Replace as needed.

DISASSEMBLE FOR CLEANING AND SERVICE

CLEANING

When to Clean:

Depending on the material being processed and the frequency of use, the slots of the drum may need to be cleaned after each use or periodically.

Indications that machine requires cleaning

1. Reduced trim quality
2. Visible build-up of material in the drum slots which obscure the sharp edge of the slots
3. Visible evidence of material on shear band
4. Excessive noise (machine should run quietly so that you may converse normally when it is running)

Preparation for Pressure Washer Cleaning

1. Shut off motor. Unplug power cords.
2. Verify drum retainers are lowered onto the drum and secure.
3. Position machine into the Unloading position.
4. Cover the control box with a plastic bag or other water proof material to limit the control boxes exposure to high pressure water.

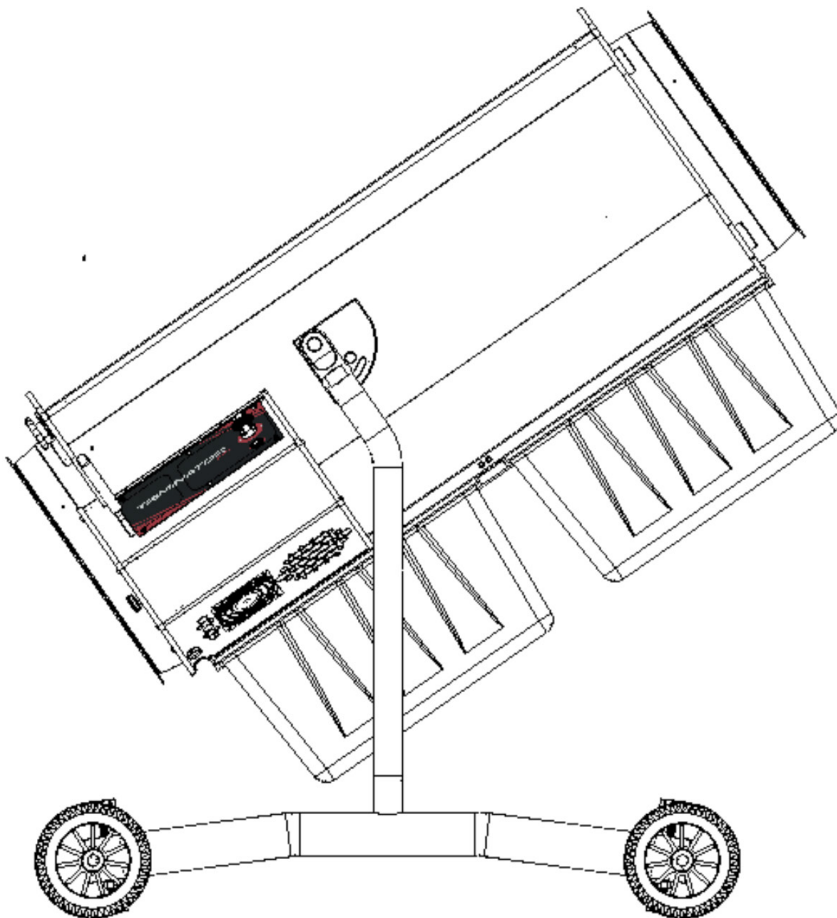

DISASSEMBLE FOR CLEANING AND SERVICE (CONT)

Disassemble for Cleaning:

Depending on how you choose to clean the machine and how dirty it is at time of cleaning, it may or may not be necessary to disassemble.

1. Shut off motor. Unplug power cords.
2. Release tension on the shear band:
 - a. Turn the tension adjustment knob clockwise slightly to release tension on the ratchet.
 - b. While turning the tension adjustment as described above flip the pawl off of the ratchet so it is no longer in contact.
 - c. Release the tension knob; the shear band will now hang freely within the trimmer.
3. Remove drum:
 - a. With motor off, power cords unplugged, and the machine in a horizontal position, loosen set screws (2) on drum retainers on either end of the drum and slide the drum retainers up and away from the drum.
 - b. Retract motor drive wheel away from the drum by pulling the rubber coated lever located on the out-feed side of the control box towards the operator and away from the machine. When fully retracted the motor pull pin will automatically lock it in the open position.
 - c. Employing two people, slide the drum gently from the machine and set it on a non-abrasive surface

(Tip: If the drum does not come out easily check that the shear band has been released as described in step 2.)

4. Remove Shear band:
 - a. With the drum removed, reach inside the machine and remove the shear band by gently lifting the shear band off of the metal tabs which hold it in place.
 - b. Gently remove the sheet from the machine and place it on a non-abrasive surface.

CLEANING AND REASSEMBLY

Pressure Washer Cleaning

1. Using a pressure washer spray the drum and internal cavity of the machine until drum is clean and clear of debris.
2. Rotate the drum by hand and repeat step 1 until all drum surfaces are clean.
3. If necessary remove the drum as instructed in the Optional Drum Removal section to expose the shear band.
4. Spray the shear band until it is clean and clear of debris.

Hand Cleaning

1. Cover entire drum and shear band with a thick coat of cooking oil (olive, vegetable, etc). Let it sit for 3-12hrs.
2. Using warm/hot water, concentrated dish soap and a non-metallic dish scrubber, clean the drum and other machine components by hand.

NOTICE: For best results use hot water whenever possible. Be careful when selecting the degreaser that it will not damage the painted or anodized components of the trimmer. Always follow the operating instructions provided with the pressure washer.

NOTICE: If you choose to use a pressure washer take care not to damage the trimmer's finish by holding the nozzle excessively close to the machine or by focusing the spray onto the motor or timer. These components are not intended to be waterproof and water damage is excluded from warranty coverage.

Re-assembly:

1. Verify motor is in the Off position and power cord is unplugged.
2. Install Shear band
Reach inside the machine and install the shear band by gently placing the sheet on the metal tabs until all holes are resting evenly on metal tabs on both sides of the machine.
3. Install Drum
With motor off, power cord unplugged, and the machine in a horizontal position, utilizing two or more people, slide the drum gently into the machine.
4. Slide the drum retainers down until they reach the bottom of their range, tighten set screws (2) on drum retainers on either end of the drum.

CLEANING AND REASSEMBLY (CONT)

5. Re-tension the Shear band

- a. Flip the pawl so it is in contact with the ratchet and prevents the ratchet from moving in a counter clockwise direction.
- b. Turn the tension adjustment knob clockwise slightly until you encounter minor resistance and the shear band has come in full contact with the drum.
- c. Allow motor drive wheel to come in contact with the drum by pulling the rubber coated lever located on the out-feed side of the control box towards the operator and away from the machine. While pulling, pull the pull pin out and away from the motor control box allowing the lever and wheel to move toward the machine and drum.

NOTICE: Very little tension is needed to create an effective cutting surface. As soon as full contact between drum and shear band has been achieved, release the tension knob.

DO NOT OVER TIGHTEN. DO NOT USE TOOLS OR OTHER MECHANISMS TO TIGHTEN TENSION.

TAKING CARE OF UNEXPECTED PROBLEMS

ELECTRIC MOTORS WILL NOT START OR HAVE LOW POWER

POSSIBLE CAUSE	CORRECTION
No electric power from the outlet	Plug trimmer into a functional electrical outlet.
Outlet is overloaded	Check that breaker is not overloaded and has not tripped. If tripped, switch plug to a different circuit.
Extension cord is faulty	Check that extension cord, if used, is rated appropriately for the distance and current. Do NOT use a longer cord unless the wire size is larger. Undersized extension cords may cause an under-voltage, over-current condition which could damage or destroy the drive motor and void the motor warranty.
Overcurrent circuit has been exceeded	<p>Determine the cause of the excessive circuit resistance which may include: overloaded outlet, faulty extension cord, bad outlet, underrated generator, excessively dirty machine, incorrectly tensioned shear band or an obstruction between the drum or reel and another part of the machine.</p> <p>Once the source of the resistance has been identified and resolved, reset the circuit by pressing the small button on the control panel for 3 seconds then operate the machine normally.</p>
Drum may be excessively dirty and resistance to motor may be to great.	Clean drum and shear band.

TAKING CARE OF UNEXPECTED PROBLEMS (cont)

TRIM QUALITY HAS DECREASED, FINISHED TRIM APPEARS ROUGH

POSSIBLE CAUSE	CORRECTION
Drum excessively dirty	Clean Drum and Shear band.

MACHINE MAKES A LOUD SCRAPING OR CLICKING SOUND

POSSIBLE CAUSE	CORRECTION
Drum and Shear band are excessively dirty	Clean Drum and Shear band. This is the primary cause of this issue.

DRUM DOES NOT ROTATE UNDER MANUAL FORCE

POSSIBLE CAUSE	CORRECTION
Drum and Shear Band are excessively dirty	Clean Drum and Shear band; excessive plant material has built up on these surfaces and is causing excess friction.
Tension on shear band is too tight	Reduce tension on shear band by releasing the pawl and rotating the tension knob in a counter clockwise direction until the drum can easily be rotated under manual force and the shear band is in contact with the drum.

CUSTOMER SERVICE

For all customer service inquiries or to help you diagnose any issues with your machine contact Triminorator directly:

Phone: 530.265.4277

Email: info@thetriminator.com

Web: www.theTrinator.com

LIMITED WARRANTY

TRIMINATOR EQUIPMENT

This warranty is limited to the Trinator Trimming Machine distributed by Mosman Machinery Company, Inc., Nevada City, California 95959. The following warranty applies to all Trinator products purchased directly or from retail outlets after January 1, 2013.

LENGTH OF WARRANTY

All Trinator products are covered under this warranty for a length of 24 months from the date of original purchase.

TO QUALIFY FOR THIS WARRANTY:

The product must be purchased in the United States, directly from Mosman Machinery Company, Inc. or from a dealer authorized by Mosman Machinery Company, Inc. to sell those products. This warranty applies to the first retail purchaser during the applicable warranty time period.

WHAT WILL BE REPAIRED OR REPLACED UNDER WARRANTY:

Mosman Machinery Company, Inc. will repair or replace, at its option, any part that is proven to be defective in material or workmanship under normal use and proper maintenance as prescribed in this Manual during the applicable warranty time period. Warranty repairs and replacements will be made without charge for parts or labor. Any part replaced under warranty becomes the property of Mosman Machinery Company, Inc. All new parts replaced under warranty will be considered as part of the original product, and any warranty on those parts will expire coincident with the original product warranty.

TO OBTAIN WARRANTY SERVICE:

You must call Trinator/Mosman Machinery Company, Inc. to discuss the warranty issue.

Phone: 530.265.4277

Following the qualifying phone conversation Mosman Machinery Company, Inc. may direct you to do one of the following:

At your expense, take the Trinator product, part to be replaced, or the equipment on which the part to be replaced is installed, and a proof of purchase to the Trinator dealer from whom you originally purchased the product, during the dealer's normal business hours.

Alternatively, Mosman Machinery Company, Inc. may direct you in writing (email) to deliver your product to a different location at a distance less than or equal to the distance from your current location to the dealer from which you originally purchased the product.

LIMITED WARRANTY (CONT)

EXCLUSIONS FROM WARRANTY COVERAGE

The following items and conditions are excluded from warranty coverage:

1. Any damage or deterioration resulting from the following:
 - Neglect of the periodic maintenance as specified in this manual.
 - Improper repair or maintenance.
 - The use of non-genuine Trinator parts and/or products other than those approved by Mosman Machinery Company, Inc.
 - Exposure of the product to chemical agents, sea water, sea breeze, salt or other damaging environmental phenomena.
 - Collision, deterioration, neglect, unauthorized alteration, misuse, incorporation or use of unsuitable attachments, products or parts.
 - Natural wear and tear (natural fading of painted or plated surfaces, sheet peeling and other natural deterioration).

2. Consumable parts: Mosman Machinery Company, Inc. does not warrant parts that deteriorate due to natural wear and tear.

3. Cleaning, adjustment, and normal periodic maintenance work (lubrication, blade sharpening, belt adjustments).

4. Any product that has ever been declared a total loss or sold for salvage by a financial institution or insurer.

DISCLAIMER OF CONSEQUENTIAL DAMAGE AND LIMITATION OF IMPLIED WARRANTIES:

Mosman Machinery Company, Inc. disclaims any responsibility for loss of time or use of the product, transportation costs, commercial loss, or any other incidental or consequential damage. Any implied warranties are limited to the duration of this written limited warranty. This warranty gives you specific legal rights, and you may also have other rights which vary from state to state.

