

GROWONIX

TUNED FOR GROWING



SP-1 SUBMERSIBLE PUMP OWNERS MANUAL

WWW.GROWONIX.COM



GROWONIX
TUNED FOR GROWING



1:1



THANK YOU FOR PURCHASING THIS GROWONIX SP SERIES DELIVERY PUMP.

We hope you are pleased with your purchase and that our pumps will provide you with long service life and exceptional performance.

To ensure satisfactory service life, there are several considerations regarding proper installation, operation and power source.

Please review the recommendations outlined within the installation and operation manual. Please contact ***YOUR*** supplier (supplying dealer or contractor) if service is necessary or if you have any questions or need further assistance.

Please retain the following information for your records and to help expedite service:

ORIGINAL SALES RECEIPT:

IMPORTANT SAFEGUARDS

To reduce risk of injury, always follow these instructions and safety precautions when using this pump and to maintain warranty.

READ ALL INSTRUCTIONS PRIOR TO INSTALLATION (SAVE THESE INSTRUCTIONS)

INSTALLATION/OPERATION:

- Never lift or carry pump by the electrical cord. Use a chain or rope affixed on handle to install/remove pump. To reduce potential damage to the pump from inadvertent lifting by the electrical cord, please refer to “Proper Lifting” located on the following page.
- Pump(s) are able to operate whether fully or partially submerged (please refer to Typical Installation Diagram, page 14). Pump must be shutdown if sump, pit or pond level drops below the motor housing.
- Pump is designed to pump clean water (maximum temperature of 122°F) with suspended solids up to 3/8 of an inch. Larger solids will clog the suction strainer plate leading to dry running and subsequent failure (Note: Pumping sand, gravel, and other hard debris will shorten the life of the pump). Elevate the pump with bricks or other support above the sump, pit or pond bottom if debris is present. Consult dealer for other fluids.
- Clean filter basin when cleaning inlet filter media when pump is shutdown.
- If used with a float switch, the float must have a full range of motion to operate properly without obstruction. Consult dealer for minimum dimensions required for proper float operation.
- Pump should be mounted upright only (vertical). Never lay the pump on its side.

ELECTRICAL REQUIREMENTS:

- Pump must be operated with a GFI breaker of at least 20 amps.
- High Or Low Voltage can damage the pump. Power from your utility or generator set cannot be more or less than $\pm 5\%$ of the rated voltage on the pump.
- Maximum distance from power source and pump must not exceed 100 feet using 16/3 electrical cables. This distance is from the breaker box and includes the pump cord. If the run is longer, consult a qualified electrician or your dealer.
- Lightning strikes can destroy the capacitor in your pump. Ensure proper protection is provided.
- Consult operator manual for other operation and application information.

IMPORTANT SAFEGUARDS

PROPER LIFTING:

A separate chain or rope should be attached to the handle for normal lifting. Please note that this will help prevent damage due to inadvertent lifting of the pump by the power cord.



rope attached to automatic pump for lifting and installation.

rope attached to manual pump for lifting and installation.



CONTENTS

Section	Page
General application Information	7
Safety Information and Introduction & Specifications	9
Materials/Tools & Installation Instructions	10
Pump Inspection & Installation Instructions	11
Fixed application Diagram & Performance Table	13
Manual Operation Type Motor Wiring Diagram	15
automatic Operation Type Motor Wiring Diagram	15
Three Phase Motor Wiring Diagram	16
Specifications	18
Nameplate Data & Model No./Item No. Explanation	20
Troubleshooting Checklist & Maintenance Info	21
Date Code Information	22
Sectional View & Parts reference	23
Disassembly & assembly Info	32
Warranty Information	33

GENERAL APPLICATION INFORMATION

THE SUMP AND INSTALLATION

If your basement does not currently have a sump installed, it would be necessary to check local plumbing codes as to the acceptable type of sump that may be used. Materials commonly specified are: clay tile, fiberglass, steel, concrete and polyethylene. It may be necessary to cut a hole in the basement floor and excavate for the sump. Plumbing and electrical contractors could advise you on proper installations of drain tiles, sump, pump and electrical service. GrowoniX recommends that a solid sump base be provided. The sump is fed by drain tile placed around the outside and/or inside basement walls at the footings. In applications where a gravel base must be used to relieve hydraulic pressure under the basement floor, be sure to provide a permanent and solid base for the pump (bricks or a steel plate). a sump cover capable of supporting 200 pounds should be employed to contain odors and for obvious safety reasons.

ELECTRICAL INSTALLATION

Electrical service for any sump pump installation must be grounded and separately fused or breakered directly from the entrance box with a single grounding type receptacle at the pump. The receptacle should not be less than four feet above the basement floor for safety reasons. You should never touch a sump pump or discharge piping while the pump is connected to electrical power and water is present. The pump should be disconnected from the electrical source before handling in all cases.

GENERAL APPLICATION INFORMATION

DISCHARGE PIPING INSTALLATION

To assure the maximum performance from your sump pump, the discharge pipe size and piping fittings should not be smaller than the discharge port of the pump. Smaller pipe will add to friction losses and reduce the capacity of the pump. Normally accepted materials are galvanized pipe, rigid plastic pipe or acceptable flexible pipe or hose. a piece of flexible hose between the pump discharge and the discharge piping will provide for ease in alignment, reduce vibration and noise, and will act as a union when it is necessary to remove the pump. Where the discharge pipe is long, a check valve is often employed to prevent the water from flowing back into the sump when the pump turns off. If the discharge is directed into a sanitary sewer, a suitable anti-siphon device or a free flow check valve should be inserted in the line to prevent backflow into the pit. Sump pumps are not designed to handle raw sewage. Do not attempt to adapt one for this type of application. a sewage ejector pump especially designed to handle solids must be used.

PUMP INSTALLATION

When the sump, electrical and discharge plumbing installation is complete and ready for the pump, clean all solid debris from the pit. Complete the plumbing connection to the pump and then plug the pump into the electrical outlet. a few extra minutes to test the sump pump installation are now in order. Fill the sump with water, note the turn on and turn off level of the pump, and the pumping cycle. This will allow you to calculate the approximate discharge flow of the pump system. If everything is operating properly, install the sump cover.

PUMP SELECTION

The pump should be of sufficient capacity and head to satisfy anticipated use requirements. Capacity is determined by a fixture unit value if effluent is drained to sump basin. Your local Wholesaler can assist you in fixture unit values. basement perimeter water intrusion varies by area and region. Typically a 1/3 HP or 1/2 HP DRAINAGE PUMP WILL EVACUATE MOST HOME SUMP PITS.

Commercial and industrial drainage applications require that of pumping volume and pumping head be performed to determine the proper size pump is applied.

NOTE:

Pumping volume may vary seasonally due to rainfall and area run-off.

GENERAL APPLICATION INFORMATION

BASIN AND COVER

The basin should not be less than 18 inches in diameter and 24 inches deep. Larger diameters are advisable in instances of increased pump capacity requirements:

Required Pump Capacity	Minimum Basin Diameter
up to 35 GPM	18"
over 35 GPM	24"
over 60 GPM	30"
over 100 GPM	36"
over 150 GPM	48"

The basin should be located such that all water flows into the basin due to gravity. Outdoor installations should be at a sufficient depth to ensure protection from freezing.

NOTE:

GrowoniX SP-1 automatic can operate in a 12" diameter basin or 8" x 8" square basin.

MAINTENANCE TIPS

• **Every three or four months:**

- 1) Clean the pump screen or inlet opening. If your sump collects the discharge from an automatic washing machine, cleaning will be required more often. (before removing the pump be sure to disconnect the unit from electrical power; and reconnect after completion of cleaning);
- 2) Pour enough water into the sump to cycle the pump and assure its proper functioning.

• **Annually:**

Remove and clean the pump. Clean the sump pit also.

SAFETY INFORMATION AND INTRODUCTION

WARNING



Before handling this pump, always disconnect the power first.

This pump should only be serviced by a qualified person or a factory trained person.

CAUTION

This instruction manual includes necessary items for installation, operation and maintenance. Read this manual carefully to ensure correct installation, operation and maintenance.

Be sure to keep this instruction manual on hand for future reference.

SPECIFICATIONS

CAUTION

Be careful not to exceed the given specifications in the use of your products.

Check the nameplate for your pump's head (HEAD), discharge volume (CAPACITY), speed (SPEED), motor voltage and current. Other specifications are noted in the chart below:

ITEM NO.	MODEL	DISCHARGE DIA. INCH	MOTOR OUTPUT (HP)	MOTOR PHASE	VOLTAGE	WEIGHT
MANUAL OPERATION						
SP-1M	32Z707U6.3S/A	1-1/4"	1/3	1	115	11

TOOLS NEEDED

- Screw driver
- Pipe wrench
- Adjustable wrench (medium-large)
- Hacksaw with 24-tooth blade for cutting plastic pipe
- Knife or round file for smoothing inside of all plastic pipe connections

MATERIALS NEEDED

- PVC or ABS pipe cement (read manufacturer's instructions carefully)
- PVC or ABS pipe;
 - 1 1/4" for SP-XX-3 & EPD-3
 - 1 1/2" for EPD-5,7,10 & 15
- PVC adapter
 - 1 1/4" for SP-XX-3 & EPD-3
 - 1 1/2" for EPD-5, 7, 10 & 15
- In line check valve
- Sump basin 18" or larger diameter plastic, fiberglass or concrete. (See page XX for minimum diameter basin size by pump capacity.)
- Optional: gate valve (see installation drawing on page XX)

INSTALLATION INSTRUCTIONS

STEP 1: Inspection: Your pump has been carefully packaged to prevent damage during shipping. However, occasional damage does occur due to rough handling. Carefully inspect the pump for damage that could cause it to fail.

STEP 2: Attach desired length of PVC or abS discharge pipe to pump outlet, using PVC adapter (1 1/4" pipe and adapter for SP-XX-3 & EPD-3 1 1/2" for EPD-5, 7, 10 & 15). Make sure open end of pipe will be above top of basin.

STEP 3: Clear sump basin of any water, debris or sediment.

STEP 4: Lower pump into basin.

STEP 5: attach in line check valve to discharge pipe 12" to 18" above pump discharge with arrow pointing away from the pump (with the flow). Connect other end of check valve securely to drain pipe and tighten clamps.

NOTE: Do not put check valve directly into pump discharge opening.

Step 6: Drill a 1/8" relief hole in the discharge pipe 5" above pipe connection to pump.

Step 7: Plug in pump and fill sump basin with water to test unit. Pump should turn on at 13" to 14" water level. allow pump to go through several ON-OFF cycles to assure satisfactory operation.

NOTE: If pump does not operate properly, see the troubleshooting checklist on page 12.
Septic Tank Installation

The PRO•DRAINER pumps can be used to pump septic tank effluent, but must be installed as follows:

- Install pump in separate compartment at the discharge side of the septic tank. Never install pump in main tank where sludge collects.
- Use with a junction box.

WARNING: Sump basin must be vented in accordance with local plumbing codes. These pumps are not designed for and CANNOT be installed in locations classified as hazardous in accordance with the National Electric Code, ANSI/NEPA 70-1984.

ELECTRICAL INFORMATION – SINGLE PHASE

(Refer to page XX for Three phase information)

- Pumps are 115 V, 60 Hz and are grounded to prevent electrical shock.

WARNING: risk of electric shock—this pump is supplied with a grounding conductor and grounding-type attachment plug. To reduce the risk of electric shock, be certain that it is connected only to a properly grounded, grounding-type receptacle.

- Use a separate 20 amp circuit breaker or 20 amp fuse block with the pump.
- **DO NOT** use an extension cord with the pump.
- **DO NOT** cut off the ground pin or use an adapter fitting.
- **DO NOT** work on the pump or switch until any or all power cords are unplugged.

IMPORTANT INSTRUCTIONS BEFORE INSTALLATION

Failure to follow these instructions may cause serious bodily injury and/or property damage.

1. Before installing or servicing your pump, BE CERTAIN pump power source is disconnected.
2. Installation and electrical wiring must adhere to state and local codes and must be complete before priming pump. Check appropriate community agencies, or contact local electrical and pump professionals.
3. **CALL AN ELECTRICIAN WHEN IN DOUBT.** Pump should be connected to a separate 20 amp circuit breaker or 20 amp fuse block. Plugging into existing outlets may cause low voltage at motor, causing blown fuses, tripping of motor overload, or burned out motor.
4. Do not connect pump to a power supply until permanently grounded. For maximum safety, ground pump to a circuit equipped with a fault interrupter device.
5. Voltage of power supply must match the voltage of the pump.
6. before installing pump, clear sump basin of any water, debris, or sediment.
WARNING: Sump basin must be vented in accordance with local plumbing codes. GrowoniX PRO•DRAINERS are not designed for and CANNOT be installed in locations classified as hazardous in the National Electric Code, ANSI/NFPA 70.
7. The sump basin should be between 18" and 24" in diameter and made of plastic, fiberglass, or concrete.
8. The following may cause severe damage to pump and will void warranty:
 - Using an extension cord.
 - Cutting off the ground pin or using an adapted fitting.
 - Working on pump or switch while plugged in.
 - Removing motor housing, unscrewing impeller, or otherwise removing impeller seal.

PIPING

Plastic PVC pipe is shown in the illustrations, but galvanized steel or copper pipe may be used if desired. all piping must be clean and free of all foreign matter to prevent clogging. Use thread compound on all threaded joints unless specified otherwise.

SUBMERSIBLE PUMP INSTALLATION

Refer to the installation illustration on the following page for the following instructions. Be certain sump basin is clean and all power to pump is shut off. If pump fails to operate properly after installation, refer to the troubleshooting checklist on page XX or contact GrowoniX.

GENERAL MATERIALS NEEDED

- One can PVC cement (read instructions carefully)
- One can thread compound (read instructions carefully)
- One male PVC adapter: 1 1/4" for 1/3 HP; 1 1/2" for 1/2, 3/4, 1 & 1 1/2 horsepower models.
- Enough rigid PVC pipe and couplings to reach from bottom of sump basin to discharge: 1 1/4" for 1/3 HP; 1 1/2" for 1/2, 3/4, 1 & 1 1/2 horsepower models.
- One Check Valve.

TOOLS NEEDED FOR ALL PUMP INSTALLATIONS:

Pipe wrench, slot screwdriver, 24-tooth hacksaw, knife or round file.

STEP 1 – Thread male PVC adaptor into pump discharge opening.

STEP 2 – Cement a 15" piece of PVC pipe to adaptor. Use appropriate diameter piping. Drill a 1/8" relief hole in the pipe 5" above pump connection. This hole prevents pump from air-locking.

STEP 3 – Clamp Check Valve to top of 15" PVC pipe with water flow arrow pointing away from pump.

STEP 4 – Lower pump into basin. Clamp needed PVC discharge pipe and fittings to open end of Check Valve.

STEP 5 – Plug in pump and fill sump basin with water. Pump should turn on at 13" to

PERFORMANCE TABLE				
TOTAL HEAD	5	10	15	20
SP-1 CAPACITY (GPM)	40	33	25	14

Motor Wiring Diagram

Manual Operation Type Output (Single Phase)

- Output $\frac{1}{3}$ to $\frac{3}{4}$ HP

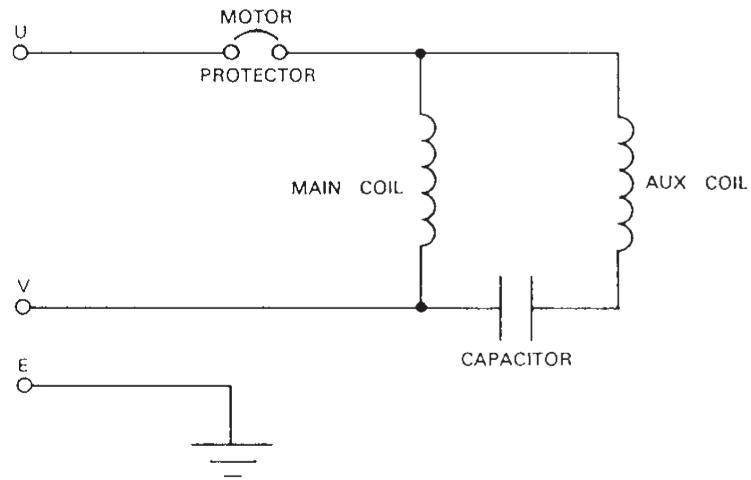

Manual Operation Type Output (Three Phase)

- Output $\frac{1}{2}$ to $1\frac{1}{2}$ HP

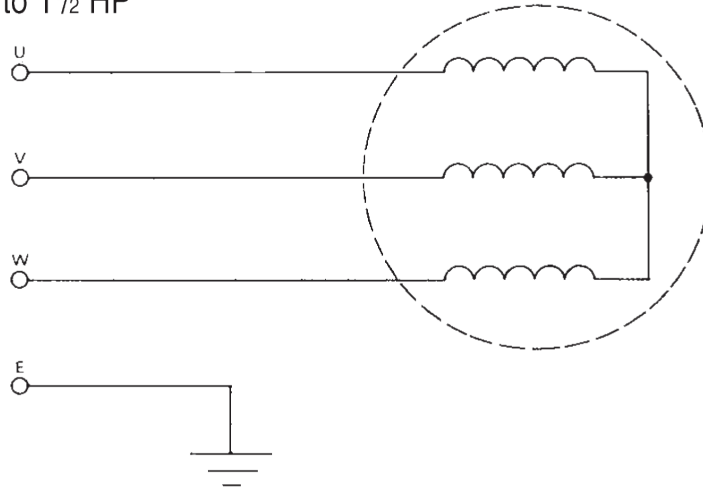

Automatic Operation Type Output (Single Phase)

- Output $\frac{1}{3}$ to $\frac{3}{4}$ HP

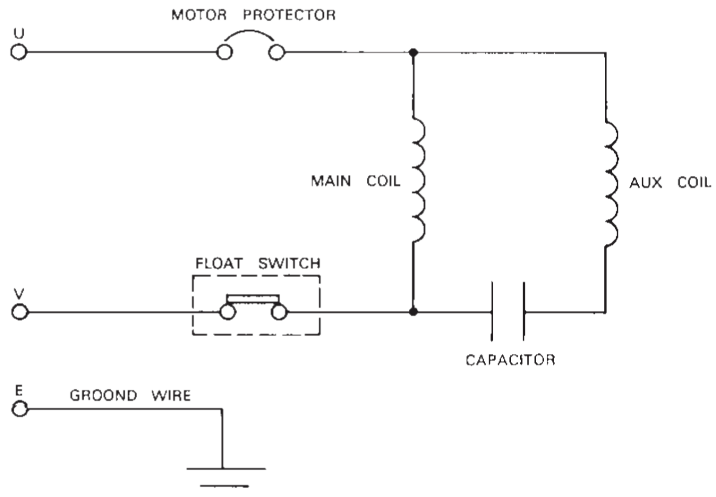

SPECIAL NOTICE

FOR CORD CONNECTED PUMPS

GROWONIX SP SERIES PUMPS ARE NOT DESIGNED FOR AND CANNOT BE INSTALLED IN ANY LOCATION CLASSIFIED AS HAZARDOUS BY THE NATIONAL ELECTRIC CODE ANSI/NFPA 70.

- Connection devices shall provide for a watertight connection to the power supply and provide adequate strain relief for the cord.
- Installation of the box shall be a Listed watertight connection box used with a Listed, liquid-tight fitting suitable for the cord.
- Connection boxes should be sized in accordance with National Electric Code specifications and installed as intended for the application.
- All connection devices are to be provided by the installer.
- Only qualified personnel shall service and install the pump.

SPECIFICATIONS

**MODEL: SP-1M
SP-1A
SP-XX**

Automatic Operation Pumps

Performance: ISO 2548

	Standard	Optional
Discharge Size	1/3 HP – 1 1/4 inch	
Range of HP	1/2 HP and 3/4 HP – 1 1/2 inch	
Range of Performance	1/3, 1/2, and 3/4 HP Capacity 2.7 to 72 GPM Head 9.3 to 57 feet	
Limitation Maximum Water Temperature	122°F/50°C	
Solids	3/8" Spherical (2% by concentration)	
Speed	3600 RPM	
Materials Casing Impeller Shaft Motor Frame Fasteners	304L Stainless Steel 304L Stainless Steel* 303 Stainless Steel 304L Stainless Steel 304L Stainless Steel	
Shaft Seal (Double)** Material – Upper Side Material – Lower Side Impeller Type Bearing Motor Single Phase Motor Protection Power Cord Automatic Float Switch	NBR Fitted Carbon/Ceramic 1/2, 3/4, 1, and 1 1/2 HP NBR Fitted SiC/SiC 1/2, 3/4, 1, and 1 1/2 HP Semi-Open Sealed Ball Bearing Air-filled, Insulation Class F, 2 Pole, Rated Continuous Duty– Permanent Split Capacitor 115 Volt Built-in Motor Protection with Auto Reset UL/CSA SJTow-A with ECS No. 250 capplug with grounding pin – 20 Ft. Length Rated 15 Amp 125V – NEMA 5-15P Mechanical Float	

* ITEM NO. SP-XX – Impeller material is Thermo Plastic-Noryl GFN2

** SPXX – 1/3 HP Shaft Seal is single mechanical seal (lower side) and 1 lip seal (upper side)

– Mechanical Seal material: Carbon/Ceramic/FPM

TROUBLESHOOTING CHECKLIST

PROBLEM	POSSIBLE CAUSES
Pump does not run or hums.	<ul style="list-style-type: none"> • Line circuit breaker is off, or fuse is blown or loose. • Water level in sump has not reached turn-on level as indicated in installation drawing. • Pump cord is not making contact in receptacle. • Float is stuck. It should operate freely in basin. • If all of the above are OK, then the motor winding may be open.
Pump runs but does not deliver water.	<ul style="list-style-type: none"> • Check valve is installed backwards. Arrow on valve should point in direction of flow. • Discharge shut-off valve (if used) may be closed. • Pump is air-locked. Start and stop several times by plugging and unplugging cord. Check for clogged vent hole in pump case. • Impeller or volute openings are fully or partially clogged. Remove pump and clean. • Inlet holes in pump base are clogged. Remove pump and clean the openings. • Vertical pumping distance is too high. Reduce distance or resize pump.
Pump runs and pumps out sump, but does not stop.	<ul style="list-style-type: none"> • Float is stuck in up position. Be sure float operates freely in basin. • Defective float switch.
Pump runs but delivers only a small amount of water.	<ul style="list-style-type: none"> • Pump is air-locked. Start and stop several times by plugging and unplugging cord. Check for clogged vent hole in pump case. • Vertical pumping distance is too high. Reduce distance or resize pump. • Inlet holes in pump base are clogged. Remove pump and clean the openings. • Impeller or volute openings is fully or partially clogged. Remove pump and clean.
Fuse blows or circuit breaker trips when pump starts.	<ul style="list-style-type: none"> • Pump impeller is partially clogged with tar or paint, causing motor to run slow and overload. Remove pump and clean. • Pump impeller is partially clogged with tar or paint, causing motor to run slow and overload. Remove pump and clean. • Motor stator may be defective. • Fuse size or circuit breaker may be too small. • Impeller or volute openings are fully or partially clogged. Remove pump and clean.
Motor runs for a short time, then stops.	<ul style="list-style-type: none"> • Inlet holes in pump base are clogged. Remove pump and clean the openings. • Pump impeller is partially clogged with tar or paint, causing motor to run slow and overload. Remove pump and clean. • Motor stator may be defective. • Impeller or volute openings are fully or partially clogged. Remove pump and clean.

Maintenance and Service

WARNING: Pump warranty becomes void if you remove motor housing, unscrew impeller, or otherwise remove impeller seal.

If pump does not operate properly, follow the steps shown under Troubleshooting.

For any work on pump or switch, always unplug power cord(s). Do not just turn off circuit breaker or unscrew fuse.

Cleaning float

If pump becomes inoperative because of trash accumulation on the float, remove pump from sump and clean float switch.

Wipe all water and dirt from the pump and float switch.

Be sure float switch operates freely after cleaning.

Cleaning impeller and volute case

Remove screws that hold lower base to housing.

CAUTION: Do not remove motor housing or unscrew impeller. Use screwdriver to pry base from housing. Pry in several places.

Be sure impeller turns freely after cleaning. Clean out holes in the pump base and wash thoroughly before replacing.

GROWONIX WARRANTY

GrowoniX warrants to the original purchaser only ("Customer") that the Commercial Pump/Product ("Pump") Model SP-1 and/or SP-XX ONLY will be free of defects in workmanship and material for a period of twelve (12) months from the date of installation or eighteen (18) months from the date of shipment by

GrowoniX, whichever comes first, provided that notification of any such defect is promptly given in writing to GrowoniX. Customer may be required at GrowoniX's request to verify that it is the Customer of the Pump and that the Pump was installed and operated in accordance with GrowoniX's instructions for sump pumps noted in the furnished instruction manual. GrowoniX's sole obligation under this MODEL SP-XX NO FAULT LIMITED WARRANTY will be to replace the Pump or at GrowoniX's sole option, to refund the Customer an equitable part or the entire purchase price. In no event shall GrowoniX's cost responsibility exceed the initial purchase price paid by the Customer for the Pump. Freight charges for replacement pumps under this MODEL SP-XX NO FAULT LIMITED WARRANTY are the responsibility of the Customer. To obtain MODEL SP-XX NO FAULT LIMITED WARRANTY consideration, the original Pump label sticker affixed to the Pump must be removed, submitted and received by GrowoniX before replacement Pump or refund is provided at GrowoniX.

attn: GrowoniX
16120 Cohasset St.
Van Nuys, CA 91406

GrowoniX shall be liable only for the cost of the replacement Pump. Customer shall be responsible for labor, cost of removal and installation at Customer's premises, transportation and insurance costs to GrowoniX and any other incidental costs. This warranty is void and does not apply if damage is caused by improper installation, improper maintenance, accident, alteration, abuse, or misuse.

THE FOREGOING WARRANTY IS THE SOLE AND EXCLUSIVE WARRANTY ON THIS PUMP, AND ALL OTHER WARRANTIES, EXPRESSED OR IMPLIED, INCLUDING ANY WARRANTY OF MERCHANTABILITY OR FITNESS FOR A PARTICULAR PURPOSE, ARE DISCLAIMED AND EXCLUDED FROM THE TERMS OF THIS WARRANTY. GROWONIX'S SOLE OBLIGATION IN CASE OF ANY DEFECT WILL BE TO PROVIDE THE WARRANTY SERVICE SPECIFIED ABOVE. THE FOREGOING IS CUSTOMER'S SOLE AND EXCLUSIVE REMEDY, WHETHER IN CONTRACT, TORT OR OTHERWISE AND GROWONIX SHALL NOT BE LIABLE FOR ANY CONSEQUENTIAL OR INCIDENTAL DAMAGES OF ANY KIND WHATSOEVER.