

## ASSEMBLY - MINI SPEED CONTROL BOX

- \* The Speed Control Box is not waterproof. Before washing your trimmer, remove the control box using the wing nuts and quick disconnect cable.
- \* The Speed Control Box comes with a 2 years warranty.
- \* Make sure the machine is unplugged.

### STEP 1

REMOVE BELT COVER.

5/32" T-HANDLE ALLEN WRENCH.

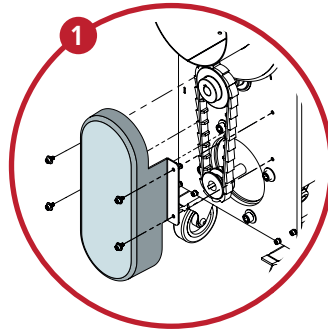

### STEP 2

USE A PRYBAR OR SCREW-DRIVER TO REMOVE BELT FROM PULLEYS.

TO AVOID DAMAGE, DO NOT PRY AGAINST BEARING.

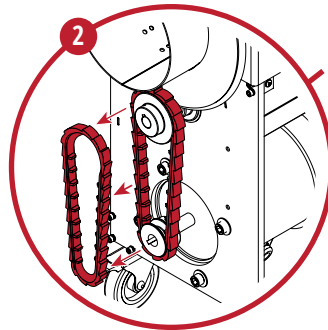

### STEP 3

REMOVE THE MOTOR BY REMOVING THE FOUR MOUNT BOLTS.

5/16" T-HANDLE ALLEN WRENCH.

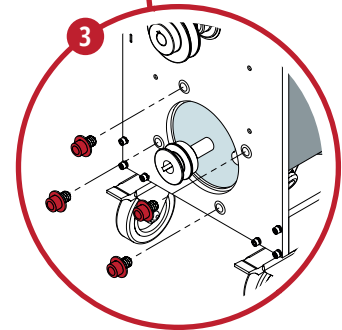

### STEP 4

REMOVE SWITCH BOX BY USING AN ALLEN WRENCH TO REMOVE THE TWO MOUNT SCREWS.

5/32" T-HANDLE ALLEN WRENCH.

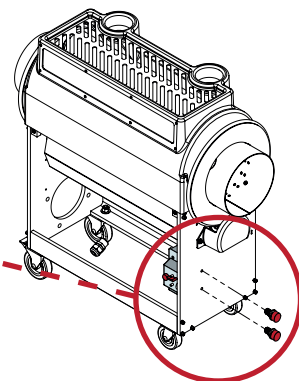
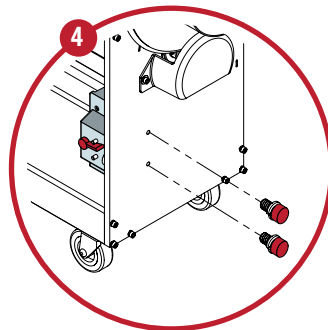

TOOLS REQUIRED

SIZE	TOOL ITEM
5/32"	T-Handle Allen Wrench
5/16"	T-Handle Allen Wrench

**LEARN  
HOW NOW**



## ASSEMBLY - MINI SPEED CONTROL BOX

### STEP 5

INSTALL NEW MOTOR WITH NEW PULLEY USING THE FOUR MOUNT BOLTS.

5/16" T-HANDLE ALLEN WRENCH.

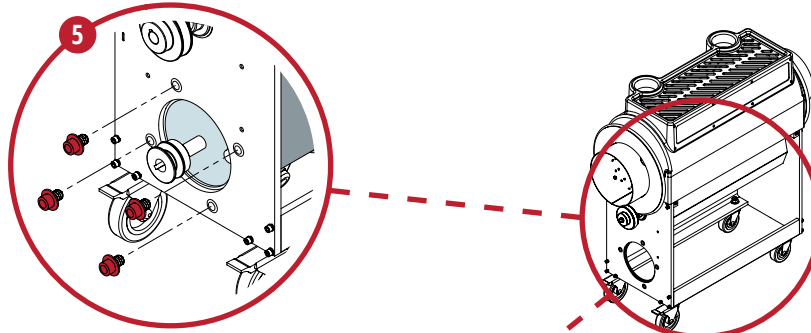

### STEP 6

INSTALL THE CONTROL BOX WITH THE SAME 2 HOLES USED TO MOUNT THE SWITCH BOX, WITH 2 NEW SCREWS AND WING NUTS. ORIENTATE CONTROL BOX AS SHOWN.

5/32" T-HANDLE ALLEN WRENCH.

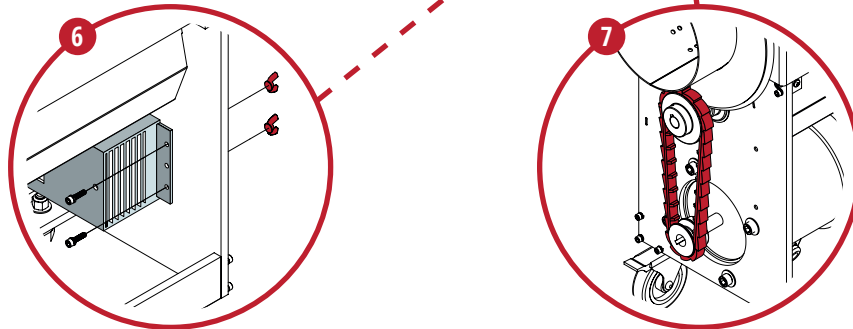

### STEP 7

INSTALL THE NEW BELT ONTO THE PULLEYS USING A PRY-BAR OR SCREWDRIVER. ADJUST PULLEY ALIGNMENT SO THAT BELT RUNS STRAIGHT.

TO AVOID DAMAGE, DO NOT PRY AGAINST BEARING.

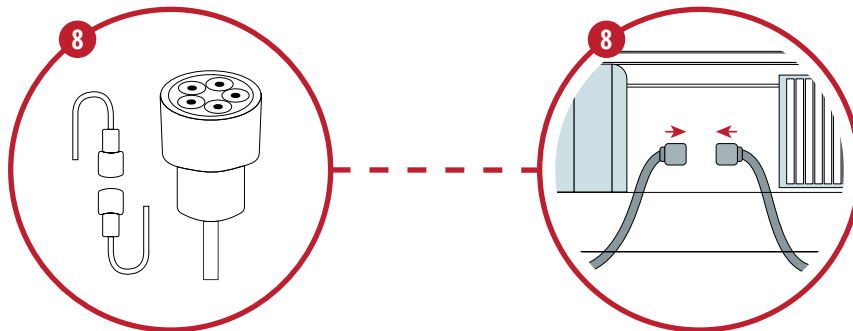

### STEP 8

CONNECT THE CONTROL BOX TO THE MOTOR.

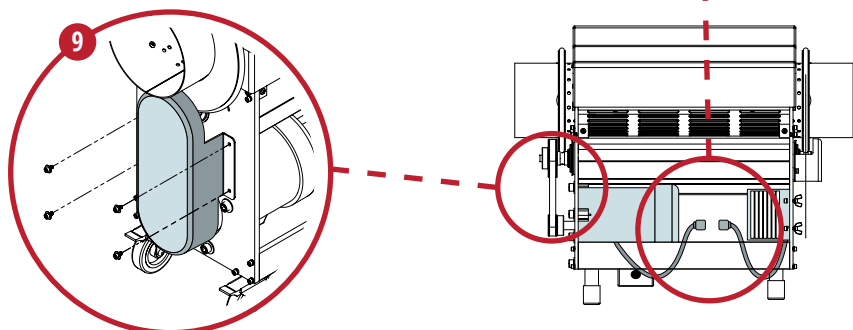

### STEP 9

RE-INSTALL BELT COVER.

5/32" T-HANDLE ALLEN WRENCH.