



# CENTURIONPRO

ELITE TRIMMING TECHNOLOGIES



## OWNERS MANUAL

### ORIGINAL & MINI CONVEYORS

# !! IMPORTANT !!

## WARRANTY

**YOU MUST REGISTER YOUR CONVEYOR WITHIN 30 DAYS OF YOUR PURCHASE**

**YOU HAVE JUST MADE A SMART DECISION BY PURCHASING A CENTURIONPRO MACHINE. FAILURE TO REGISTER YOUR MACHINE WITHIN 30 DAYS OF PURCHASE WILL VOID YOUR 1 YEAR WARRANTY. PROTECT YOUR INVESTMENT. THIS PROCESS WILL ONLY TAKE 3 MINUTES TO COMPLETE.**

### REGISTER NOW!



[cprosolutions.com/warranty](http://cprosolutions.com/warranty)

### WARRANTY TERMS AND CONDITIONS

CenturionPro Solutions (the manufacturer) will repair or replace, without charge, any parts proven defective in material or workmanship for a period of 1 year on your conveyor. Regular wear and tear of consumable parts, such as the belt and caster wheels, will not be covered under this warranty.

The warranty period will begin on the date the machine(s) is purchased by the initial purchaser. Product or component warranty defects can be remedied at any authorized service dealer, or directly at the manufacturer. Any service work performed, and deemed valid due to a defective part, will be free of charge. CenturionPro Solutions reserves the right to use any manufacturer-approved replacement part for the warranty repair.

The machine or defective part then must be returned to the manufacturer for analysis or replacement at the cost of the owner. Parts deemed to be covered under the warranty will be provided for free excluding shipping costs.

Do not return the machine to the place of purchase for repair or warranty claims, unless you have been authorized by CenturionPro Solutions to do so. The place of purchase can only sell replacement parts and will not repair any warranty issues, unless it is noted as an authorized repair dealer and has been authorized to work on your machine.

**IF WARRANTY REPAIR IS REQUIRED, PLEASE CONTACT THE MANUFACTURER AT 1-855-535-0558 OR [techsupport@cprosolutions.com](mailto:techsupport@cprosolutions.com) AND PROVIDE THE FOLLOWING INFORMATION:**

- 1. Model and serial number - Located on **outside of motor****
- 2. Proof of purchase date**
- 3. A copy of the original Warranty Registration Card or Online Submission**
- 4. Details of the defect or problem (include photos and videos)**

**YOU MAY BE DENIED WARRANTY COVERAGE IF YOUR MACHINE HAS FAILED DUE TO ANY OF THE FOLLOWING:**

<b>Product abuse</b>	<b>Normal wear</b>
<b>Product neglect</b>	<b>Accidental damage</b>
<b>Improper maintenance</b>	<b>Unapproved modifications</b>
<b>Improper electrical connection</b>	

### LIABILITIES

The manufacturer assumes no risk and shall be subject to no liability for damages or loss resulting from the specific use or application made of the product. In no event will the manufacturer be liable for any special, incidental or consequential damages (including loss of use, loss of profit and claims of third parties) however caused - whether by negligence of the manufacturer or otherwise. If you have any questions regarding your warranty rights and responsibilities, please contact the manufacturer.

### LEGALITIES

CenturionPro machines are intended for use on legal aromatic herbs and hops. Please check all municipal, provincial/state and federal laws and regulations before using these machines. CenturionPro Solutions does not promote or condone the use of these products in any way that may be deemed illegal. Allow only persons who understand this disclaimer to operate the machines.

## NOTES

---

A large grid of small dots for taking notes.

**FOR ALL OTHER ISSUES, PLEASE EMAIL [techsupport@cprosolutions.com](mailto:techsupport@cprosolutions.com), WE WOULD BE HAPPY TO HELP YOU.**

## TABLE OF CONTENTS

<b>WARRANTY</b>	<b>2</b>
<b>NOTES</b>	<b>3</b>
<b>TABLE OF CONTENTS</b>	<b>4</b>
<b>SAFETY</b>	<b>5</b>
<b>COMPONENTS OVERVIEW - QUALITY CONTROL CONVEYOR</b>	<b>6</b>
<b>CONVEYOR POSITIONING</b>	<b>6</b>
<b>COMPONENTS OVERVIEW - INFEEED CONVEYOR</b>	<b>7</b>
<b>VARIABLE SPEED CONTROL</b>	<b>7</b>
<b>ASSEMBLY</b>	<b>8</b>
<b>BELT ADJUSTMENT</b>	<b>8</b>
<b>CLEANING</b>	<b>9</b>
<b>SPECIFICATIONS</b>	<b>9</b>

## TOOL REQUIREMENTS

SIZE	TOOL ITEM
3/16"	T-Handle Allen Wrench
9/16"	Wrench
3/4"	Wrench

CONVEYOR CONNECTIONS	
CANADA, USA, MEXICO & JAPAN CONNECTOR PLUG REGULAR WALL OUTLET	

CONVEYOR - ADDITIONAL REQUIREMENTS	
EXTENSION CORD	14 AWG (min AWG SIZE)
	7.6m/25ft MAX LENGTH

CONVEYOR CONNECTIONS	
EUROPE, SOUTH AMERICA & ASIA CONNECTOR PLUG REGULAR WALL OUTLET	

### ELECTRICAL POWER SUPPLY SET-UP

TEST YOUR ELECTRICAL CURRENT TO MAKE SURE IT IS PRODUCING POWER. **WE RECOMMEND HAVING A CERTIFIED ELECTRICIAN SET UP THE PROPER POWER SUPPLY.** THIS WILL ENSURE YOUR POWER SOURCE IS SUPPLYING THE CORRECT ELECTRICITY. IF YOU HAVE NOT DONE THIS, HAVE A CERTIFIED ELECTRICIAN COME AND TEST YOUR ELECTRICAL CURRENT.

## BEFORE YOU START

### IMPORTANT SAFETY INFORMATION

We cannot warn you of every conceivable hazard that can arise in performing maintenance. Only you can decide whether or not you should perform a given task. Always follow the procedures and precautions in this owner's manual. Other uses could result in injury to the operator or damage to the Conveyor and other property.

### Safety Precautions

Make sure all motors are off and power cords are unplugged before you begin any cleaning, maintenance or repairs.

Read the instructions before you begin, and make sure you have the tools and skills required.

### CLEAR OPERATION AREA

Before operating the Conveyor, carefully inspect the surrounding area and remove all hazards that could cause you to trip, slip, or fall into the Conveyor. Anything which can be grabbed by the rotating Belt is a potential hazard to you and others. Look for hazards and remove them from the work area. Tie back loose clothing and long, loose hair. Remove any and all jewelry.

### COVERS & GUARDS

Do not alter or remove Guards or Covers, they are designed to protect you from touching moving components. For your safety and the safety of others, keep all covers and guards in place when the Conveyor is running.

### TURN MOTOR OFF WHEN NOT OPERATING THE CONVEYOR

If you need to leave or step away from the Conveyor for any reason, always make sure to turn the motor off.

### OPERATE ON FLAT SURFACE

Do not operate on slopes. To avoid overturning, only operate the Conveyor on flat surfaces. Control the Conveyor carefully when transporting it across uneven ground or slopes. Do not push the Conveyor down or across steep slopes: the Conveyor could overturn, causing damage to the machine or injury to the operator and/or bystanders.

### OPERATOR RESPONSIBILITY

Do not climb, sit or ride on the Conveyor. It is important to know how to stop the Conveyor quickly in case of emergency. Understand the use of all Conveyor controls. Never permit anyone to operate the Conveyor without proper instruction. Do not let children operate the Conveyor.

**Your safety is your responsibility.**

### PRE-OPERATION CHECK

For your safety, and to maximize the service life of your equipment, it is very important to take a few moments before you operate the to check its condition before each use. If you happen to come across any issues, be sure to take care of them before you operate the Conveyor.

Improperly maintaining this Conveyor, or failing to correct a problem before operation, could cause a malfunction which could cause you to be seriously injured. Always perform a pre-operation inspection before each use, and correct any problem.

Before beginning your pre-operation checks, be sure the Conveyor is on a level surface, the MOTOR SWITCH is in the OFF position, and all power cords are unplugged.

### CHECK THE GENERAL CONDITION OF THE CONVEYOR

Clean the Conveyor. Look for signs of damage.

Check each control for proper operation.

Check parts for wear. Replace if necessary.

Check that all nuts and bolts are tightened appropriately.



### SAFE OPERATING PRECAUTIONS

- Even if you have operated other Conveyors, to take time to become familiar with how the Centurion Pro works.
- Never operate Centurion Pro machines while under the influence of drugs, alcohol or prescriptions, including over-the-counter cold/flu/allergy medications.
- Protective clothing and eye and/or hearing protection should be worn during operation.
- For your safety, do not operate while wearing loose fitting clothing, jewelry, etc..
- Rotating machinery parts can entangle loose clothing, long hair or dangling jewelry resulting in serious injury or death.
- Long hair should be secured in a manner that keeps it away from mechanical parts.

## COMPONENTS - QUALITY CONTROL CONVEYOR

- \* Make sure the machine is unplugged when doing any cleaning or maintenance.
- \* The Motor & Speed Control Box are not waterproof. Do not get them wet.
- \* The Speed Control Box comes with a 2 year warranty.

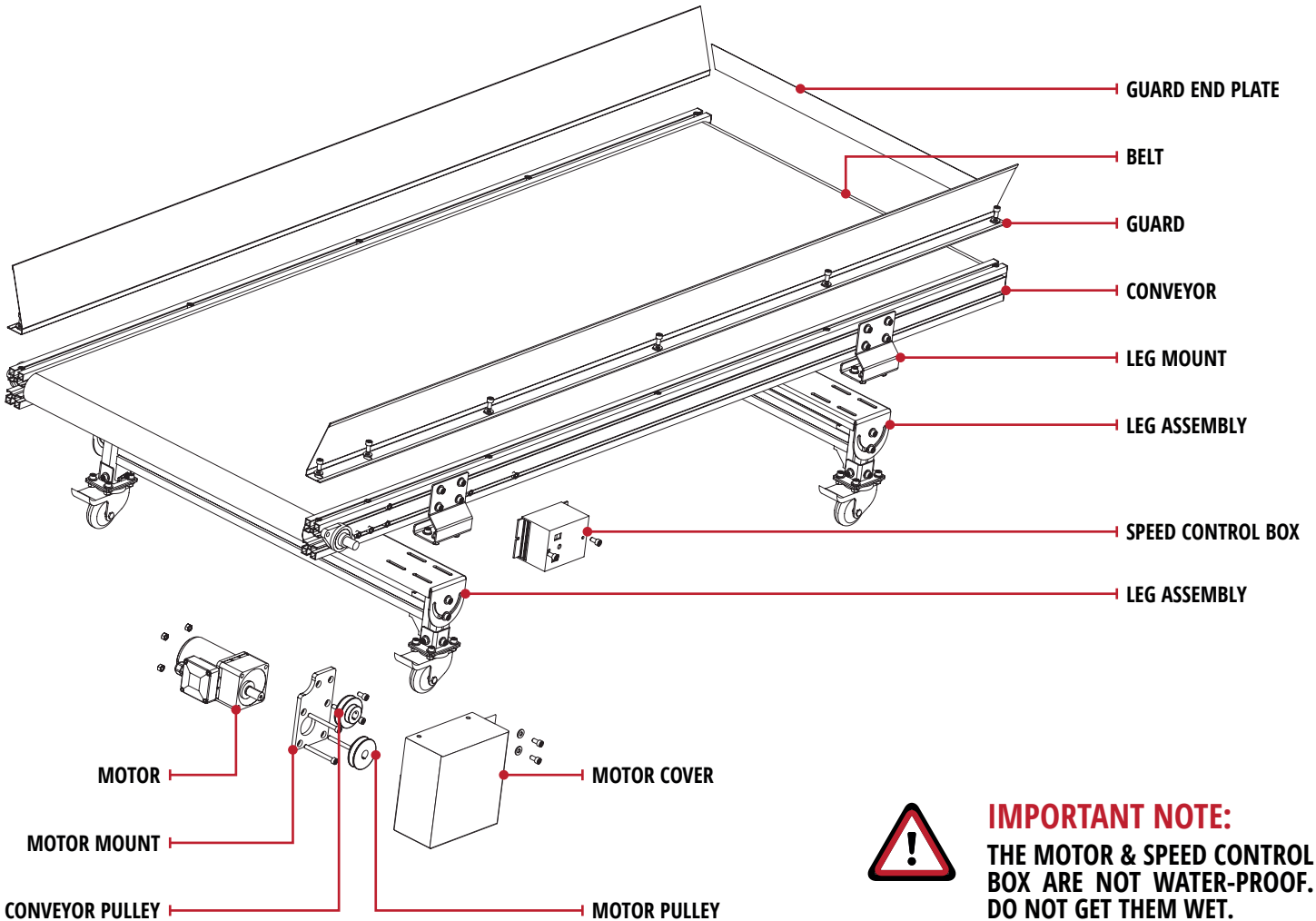

## CONVEYOR POSITIONING

### QC CONVEYOR:

POSITION THE CONVEYOR CLOSE TO THE OUTFEED TUMBLER, IN A MANNER THAT DOESN'T INTERFERE WITH THE TUMBLER WHILE IN OPERATION. ONCE IN POSITION, PRESS DOWN THE LOCKING CASTORS ON THE TRIMMER AND CONVEYOR TO PREVENT MOVEMENT.

### INFEEED CONVEYOR:

POSITION INFEEED CONVEYOR SO THAT THE CHUTE IS INSIDE THE TUMBLER. ENSURE THAT THE CHUTE WILL NOT INTERFERE WITH TUMBLERS ONCE THEY BEGIN SPINNING. THE CONVEYORS HEIGHT CAN BE ADJUSTED BY LOOSENING THE BOLTS ON EACH OF THE LEGS. ONCE IN POSITION, PRESS DOWN THE LOCKING CASTORS ON THE TRIMMER AND CONVEYOR TO PREVENT MOVEMENT.

**WITNESS THE RISE**

**RELIABLE • INDUSTRIAL • SIMPLE • EFFICIENT**

## COMPONENTS - INFEEED CONVEYOR

- \* Make sure the machine is unplugged when doing any cleaning or maintenance.
- \* The Motor & Speed Control Box are not waterproof. Do not get them wet.
- \* The Speed Control Box comes with a 2 years warranty.

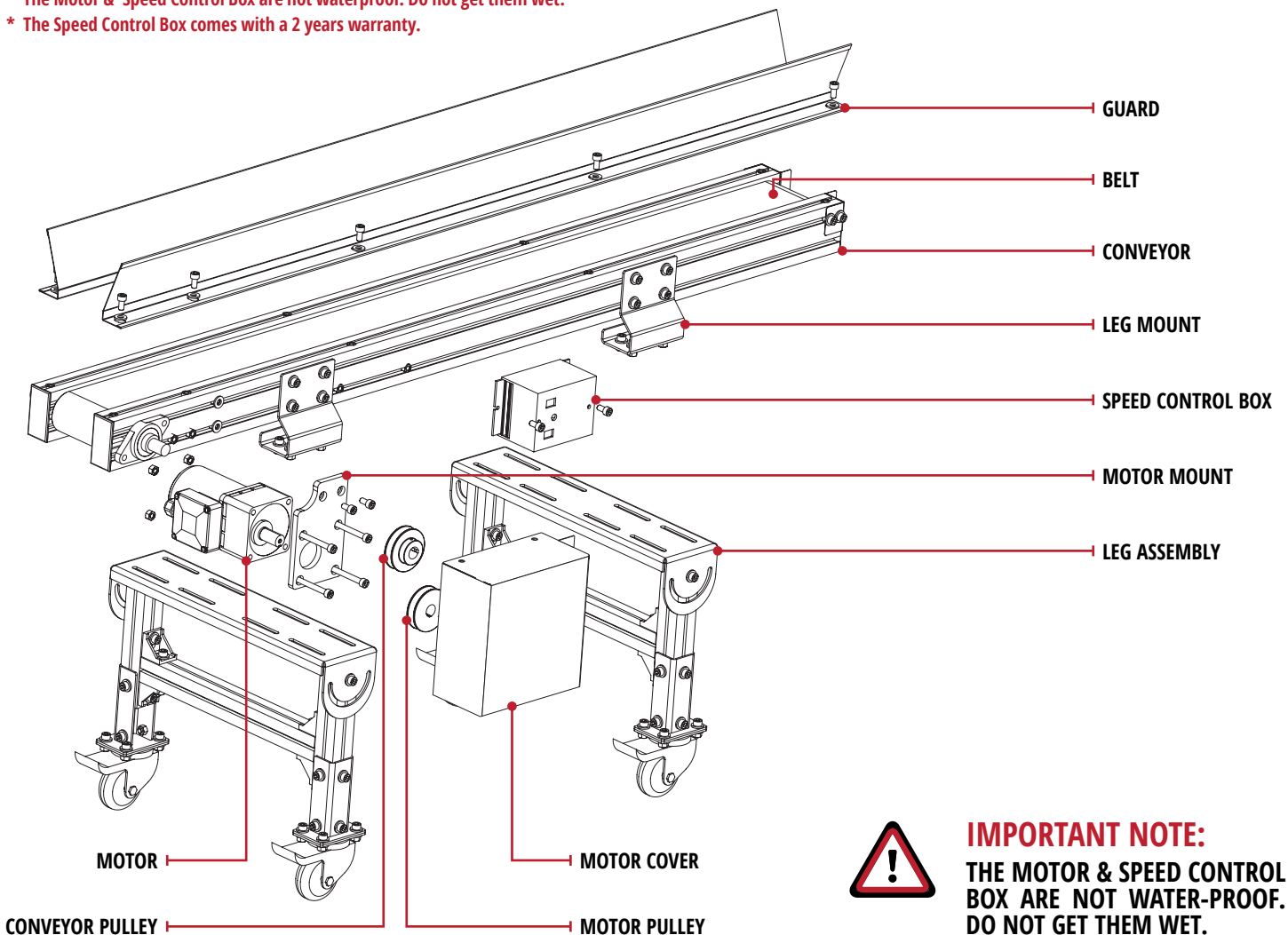

## VARIABLE SPEED CONTROL

### CONNECT POWER CORDS

1. Connect the Conveyor power cord to a 15Amp 120V(NA) / 220V (EU, AUS) circuit. Do not connect and disconnect the power cord with wet hands. Do not operate in the rain.

### STARTING THE MACHINE

1. Flip the MOTOR SWITCH to the ON position.
2. Turn the SPEED dial clockwise to set the desired speed, start off at the lowest setting and increase as required.

### STOPPING THE MACHINE

1. At any other time, turn the SPEED dial counter-clockwise, until it aligns with the ZERO.
2. Turn the MOTOR SWITCH to the OFF position.
3. Disconnect the Conveyor's power cord.

**NOTICE:** In an emergency, turn the motor switch to the OFF position.

For more information or to watch our video tutorials visit [cprosolutions.com](http://cprosolutions.com)



**ASSEMBLY**

**STEP 1**

CONNECT THE CONVEYOR BED AND THE CONVEYOR LEGS AS FIGURE ILLUSTRATES. MAKE SURE THAT THE CONVEYOR BED IS CENTERED ON THE CONVEYOR LEGS. TIGHTEN BOLTS AND NUTS TOGETHER.

3/16" T-HANDLE ALLEN WRENCH.  
9/16" WRENCH.

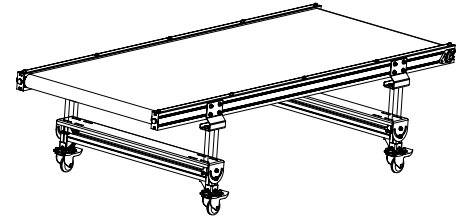
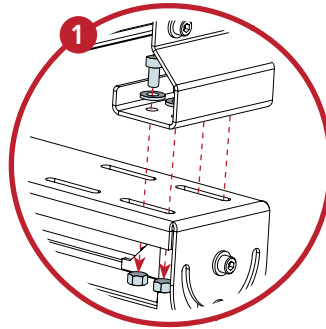

**STEP 2**

INSTALL CONVEYOR GUARDS TO TOP OF CONVEYOR SIDE RAILS AS SHOWN. THE NUTS REQUIRED ARE IN TOP SLOT OF CONVEYOR RAIL. TO RETRIEVE, REMOVE BLACK END CAP FROM END OF THE RAIL AND SLIDE NUTS INTO PLACE. ONCE CONVEYOR GUARDS ARE IN PLACE, BOLT ON GUARD END PLATE.

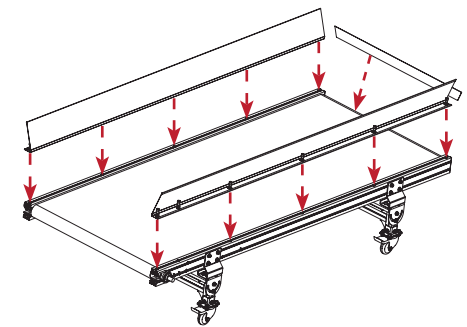
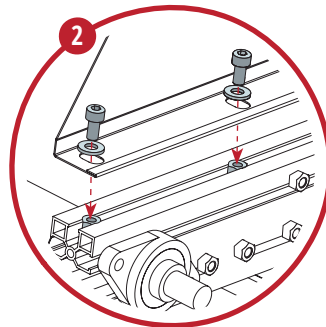

**STEP 3**

ENSURE THAT ALL BOLTS ON CONVEYOR AND CONVEYOR LEGS ARE TIGHT USING WRENCH AND ALLEN WRENCH.

3/16" T-HANDLE ALLEN WRENCH.  
9/16" WRENCH.

**BELT ADJUSTMENT**

ADJUSTING THE BELT TENSION PROPERLY WILL ENSURE THE BELT IS RUNNING STRAIGHT. AFTER CLEANING OR MAINTENANCE TIGHTEN TENSIONER BOLTS EVENLY ON THE END OPPOSITE THE MOTOR UNTIL THE BELT IS SLIGHTLY SAGGING UNDERNEATH. SIMPLY TIGHTENING YOUR TENSIONERS EQUALLY UNTIL THE BELT DOES NOT SLIP ON THE DRIVE PULLEY IS SUFFICIENT FOR TENSIONING THE BELT. ROTATING THE TENSIONER BOLT CLOCK-WISE WILL TIGHTEN THE BELT, COUNTER CLOCK-WISE WILL LOOSEN. THE TWO ROLLERS SHOULD BE PERPENDICULAR TO THE SIDE RAILS AND PARALLEL TO EACH OTHER TO ENSURE PROPER ALIGNMENT.

**NOTE: UNDER TENSIONING AND OVER TENSIONING CAN CAUSE THE BELT TO SLIP.**

**STEP 1 - TRACKING**

IF THE BELT IS TRACKING TOWARDS THE MOTOR SIDE RAILS, RUN THE CONVEYOR SLOWLY AND TIGHTEN THE MOTOR SIDE TENSIONER BOLT 1/4 TURNS UNTIL THE BELT STARTS TO TRAVEL AWAY FROM THE RAIL. LOOSEN SLIGHTLY TO STOP THE BELT FROM TRACKING IN OPPOSITE DIRECTION.

**STEP 2 - TRACKING**

IF THE BELT IS TRACKING TOWARDS THE NON-MOTOR SIDE RAILS, TIGHTEN THE NON-MOTOR SIDE TENSIONER BOLT 1/4 TURNS UNTIL THE BELT STARTS TO TRAVEL AWAY FROM THE RAIL. LOOSEN SLIGHTLY TO STOP THE BELT FROM TRACKING IN THE OPPOSITE DIRECTION.

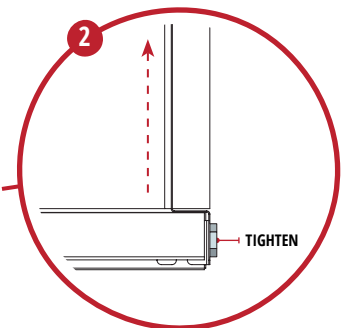
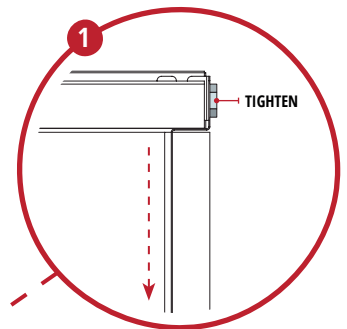

**IMPORTANT:**  
UNDER TENSIONING  
AND OVER TENSIONING  
CAN CAUSE BELT TO SLIP

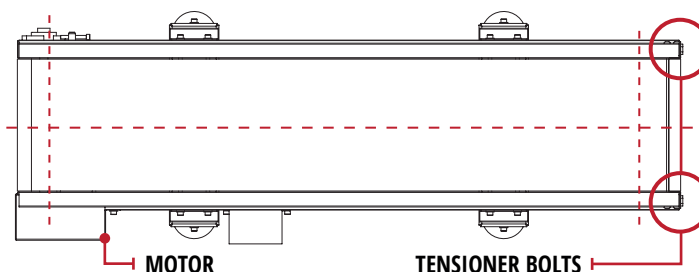



## CLEANING

### STEP 1

SPRAY BELT WITH A DISH SOAP AND WATER SOLUTION, AND WIPE CLEAN WITH A SOFT CLOTH. RINSE. THOROUGHLY DRY WITH SOFT CLOTH.

### STEP 2

LOOSEN TENSIONER BOLT USING WRENCH. ADJUST BOTH SIDES EQUALLY TO HOLD THE CONVEYOR SQUARE.

### STEP 3

THERE SHOULD NOW BE SLACK IN THE CONVEYOR BELT, WHICH WILL ALLOW ONE PERSON TO HOLD THE BELT UP, WHILE THE OTHER CLEANS UNDERNEATH THE BELT.

### STEP 4

PULL BELT AWAY FROM ROLLERS. CLEAN AROUND THE ENTIRE ROLLER ON EACH END. WIPE THE CONVEYOR FRAME TO CLEAN OFF ANY RESIDUE. ONLY USE ISOPROPYL ALCOHOL ON METAL COMPONENTS.

### STEP 5

TIGHTEN TENSIONER BOLT USING WRENCH UNTIL CONVEYOR IS TIGHT, ENSURE TO DO BOTH SIDES EVENLY TO KEEP CONVEYOR BELT SQUARE. IF THE CONVEYOR STARTS TRACKING TO ONE SIDE, ADJUST THE TENSIONING BOLTS TO CORRECT. SEE BELT ADJUSTMENT INSTRUCTIONS.

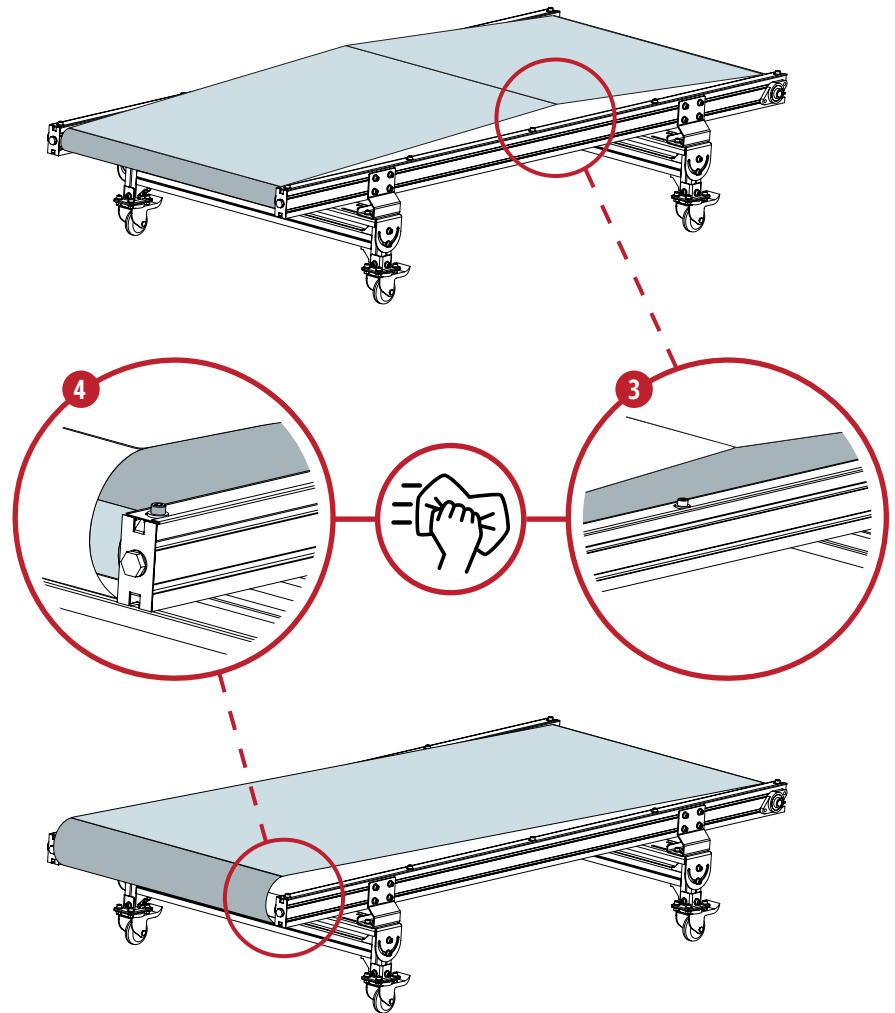

## SPECIFICATIONS

ORIGINAL CONVEYOR	
Input Voltage	1.1 Amp - 120V 60 Hz, NA 0.55 Amp - 220V 50 Hz, EU/AUS
Infeed Conveyor Dimensions (L x W x H)	60in x 7in x 20-25in 152cm x 18cm x 51-64cm
Infeed Belt Dimensions (L x W)	60in x 3.5in 152cm x 9cm
QC Conveyor Dimensions (L x W x H)	60in x 15in x 11in 152cm x 38cm x 28cm
QC Belt Dimensions (L x W)	60in x 12in 152cm x 30cm
Belt Material	Polyurethane, 1.3mm, Food Grade
Motor Horsepower	1/8 HP
Speed Range	0-10 in/s
Warranty	1 year

MINI CONVEYOR	
Input Voltage	1.1 Amp - 120V 60 Hz, NA 0.55 Amp - 220V 50 Hz, EU/AUS
Infeed Conveyor Dimensions (L x W x H)	60in x 7in x 20-25in 152cm x 18cm x 51-64cm
Infeed Belt Dimensions (L x W)	60in x 3.5in 152cm x 9cm
QC Conveyor Dimensions (L x W x H)	60in x 15in x 11in 152cm x 38cm x 28cm
QC Belt Dimensions (L x W)	60in x 12in 152cm x 30cm
Belt Material	Polyurethane, 1.3mm, Food Grade
Motor Horsepower	1/8 HP
Speed Range	0-10 in/s
Warranty	1 year



# CENTURIONPRO

ELITE TRIMMING TECHNOLOGIES



[cprosolutions.com](http://cprosolutions.com)



1 855 535 0558



[sales@cprosolutions.com](mailto:sales@cprosolutions.com)

FOLLOW US ON:

