

# Dilution™

## SOLUTIONS

To order call 1-800-451-6628

### Hi-Flo Monitor Kit Water-Powered Nutrient Delivery System

Item #:

- **HYKMON150**

#### SPECIFICATIONS

Dilution Solutions' Water-Powered Nutrient Delivery System Monitor Kit measures and displays the well-blended outgoing solution providing peace of mind. To complete the Hi-Flo Nutrient Delivery System, you will also need Dosatron Injectors, the Standard Starter Kit, Mixing Chamber Kit(s), and the Water Hammer Arrestor Kit. This part is also available without the monitor – please call 1-800-451-6628 or CHAT with us for details.

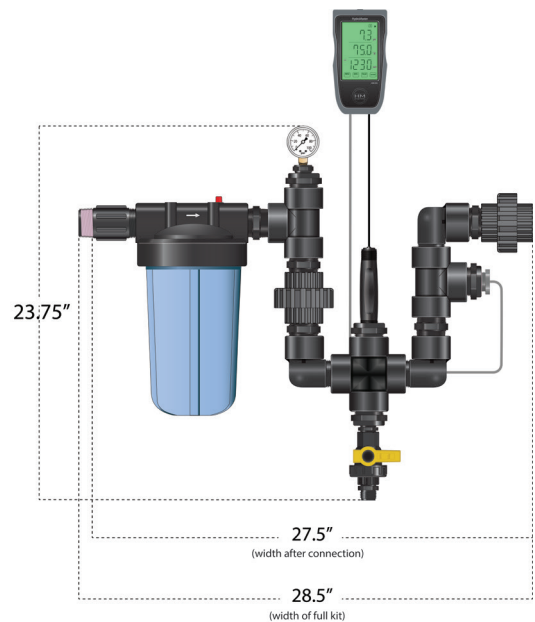

Description	Item #
Hi-Flo Water-Powered Monitor Kit 1 1/2"	HYKMON150

\*\* Parts ordered may look slightly different than the picture displayed, but the fit and function will be the same.

# Dilution™

---

## SOLUTIONS

To order call 1-800-451-6628

### Hi-Flo Nutrient Delivery System Installation

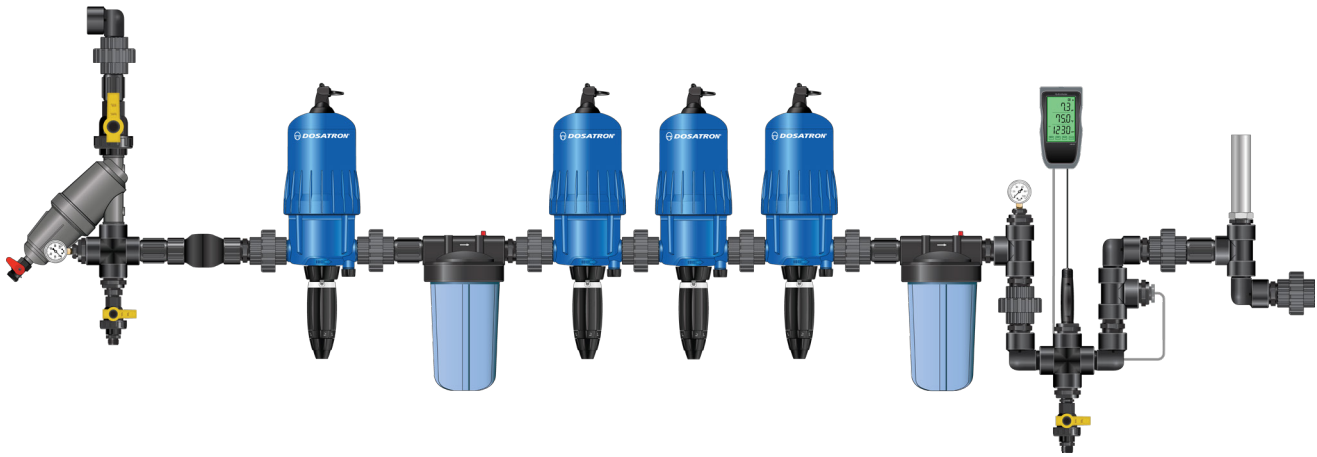

The Nutrient Delivery System is customizable,  
more dosers can be added as needed.

NOTE: Installation illustrations are to be used as a reference guide only.