

Dilution™

SOLUTIONS

To order call 1-800-451-6628

Hi-Flo Mixing Chamber Kit Water-Powered Nutrient Delivery System

Item #:

- **HYKMC150**

SPECIFICATIONS

Dilution Solutions' Water-Powered Nutrient Delivery System Mixing Chamber Kit enhances the blending as the solution passes through. It's a must for silicates. To complete the HI-FLO Nutrient Delivery System, you will also need Dosatron Injectors, the Standard Starter Kit, Monitor Kit or END Kit, and Water Hammer Arrestor Kit.

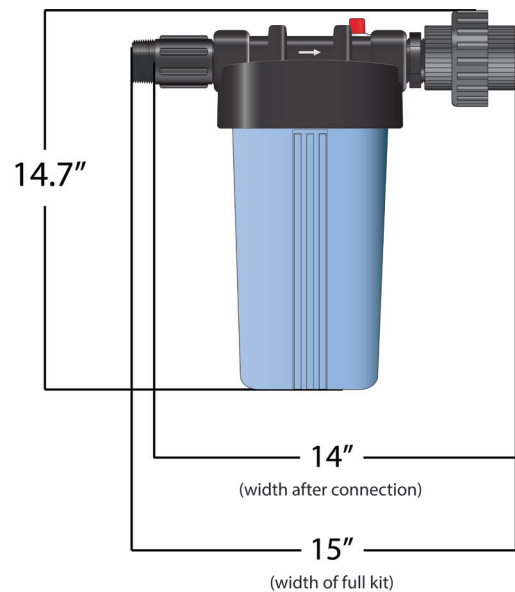

Description	Item #
Hi-Flo Water-Powered Mixing Chamber Kit 1 1/2"	HYKMC150

** Parts ordered may look slightly different than the picture displayed, but the fit and function will be the same.

Dilution™

SOLUTIONS

To order call 1-800-451-6628

Hi-Flo Nutrient Delivery System Installation

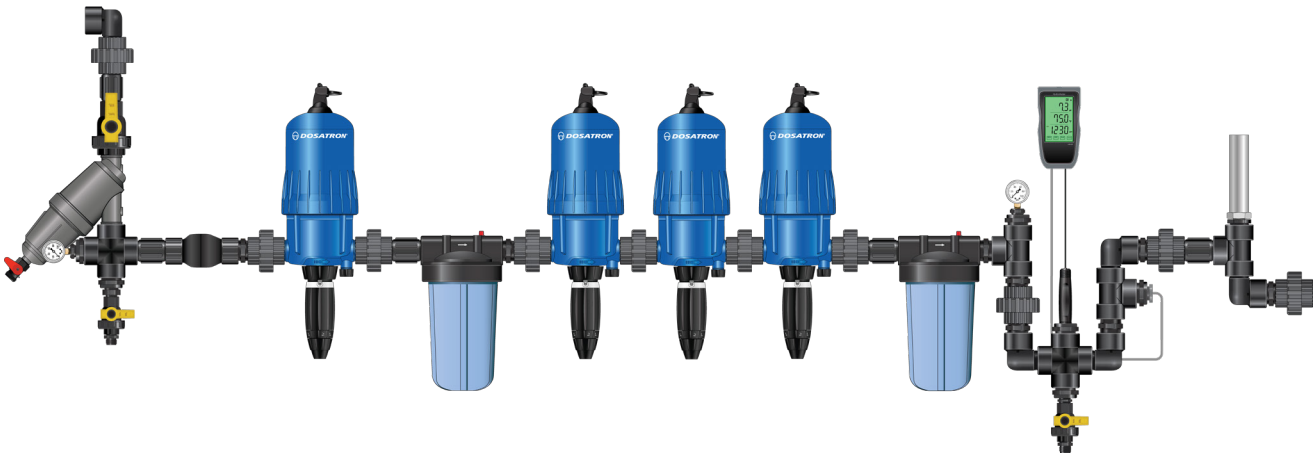

The Nutrient Delivery System is customizable,
more dosers can be added as needed.

NOTE: Installation illustrations are to be used as a reference guide only.