

VERTICAL **STAND**

Installation Guide











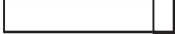
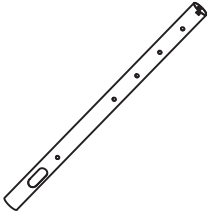
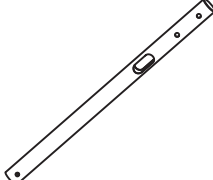
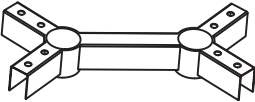
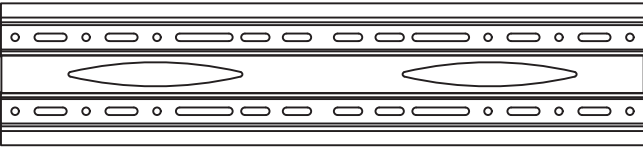

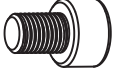

Vertical Stand Installation Guide

Please read the following warning carefully before assemble it.



WARNING:

- 1 Do not install or assemble if the product or hardware is damaged or missing. if you requirereplacement parts, please contact us for assistance.
- 2 Maximum load capacity: 50KG.
- 3 Do not use this product for any other things than the original design.
- 4 This product contains moving parts, please use it with caution.
- 5 We do not cover the following damages: product been modified, improper installation or use overthe specified weight range, nature caused damage.

					
A x2	B x2	C x2	D x2	E x1	
					
F x1			G x2	H x12	I x12 (M8*60)
					
J x2 (M10*34)	K x8 (M6*8)	L x2	M x12	N x4	O x2
					
P x2	Q x2		R x1 Wrench NO.: 5	S x1 Wrench NO.: 6	T x1 Wrench NO.: 8

Step1

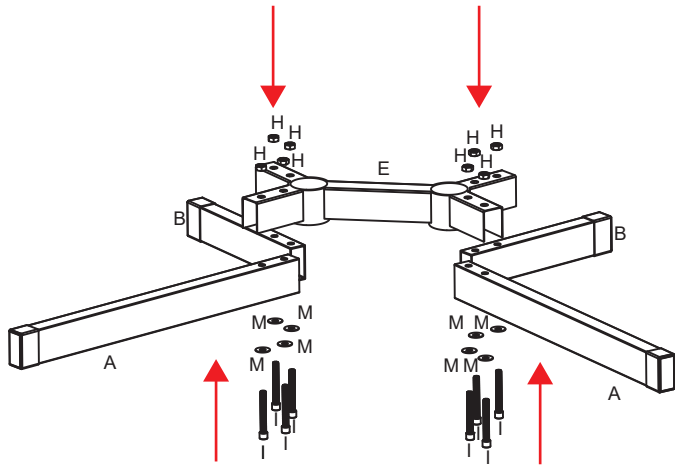

Step2

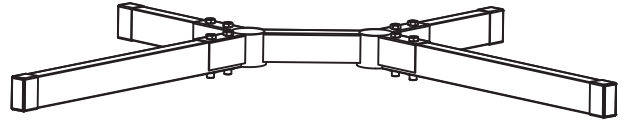

Step3

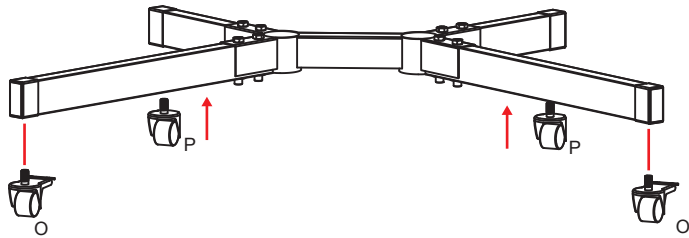

Step4

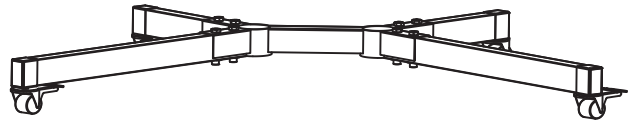

Step5

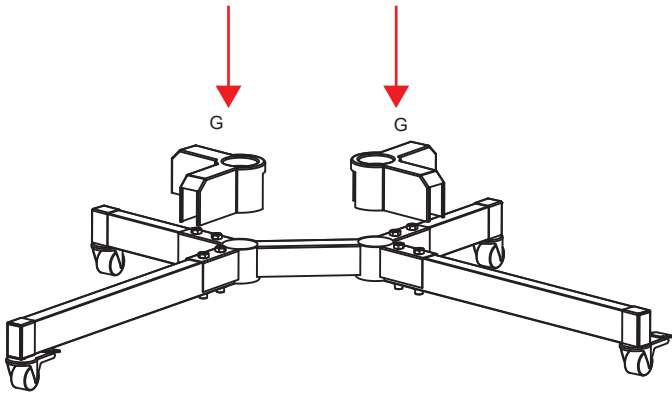

Step7

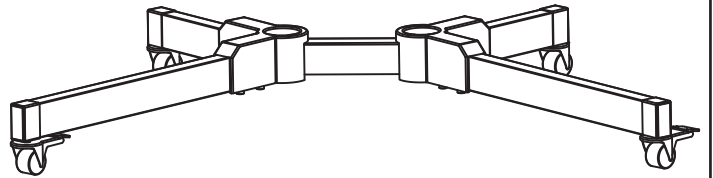

Step7

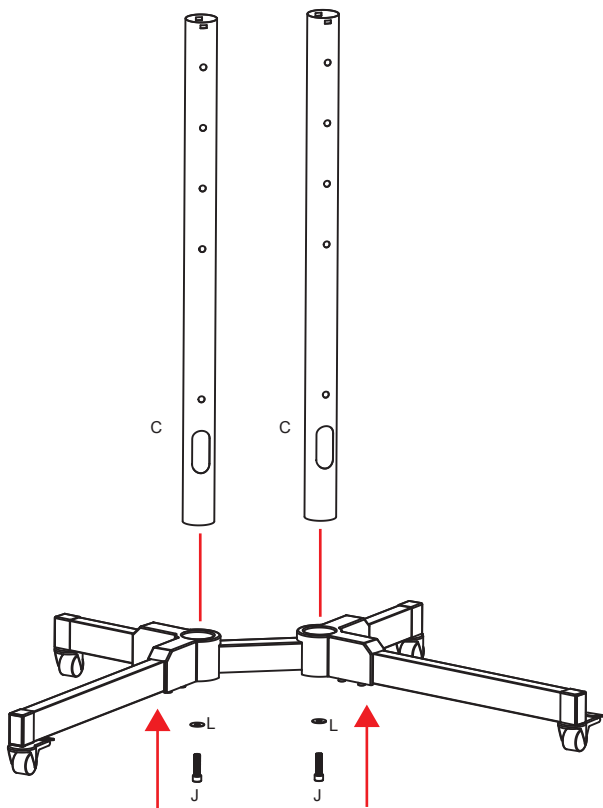

Step8

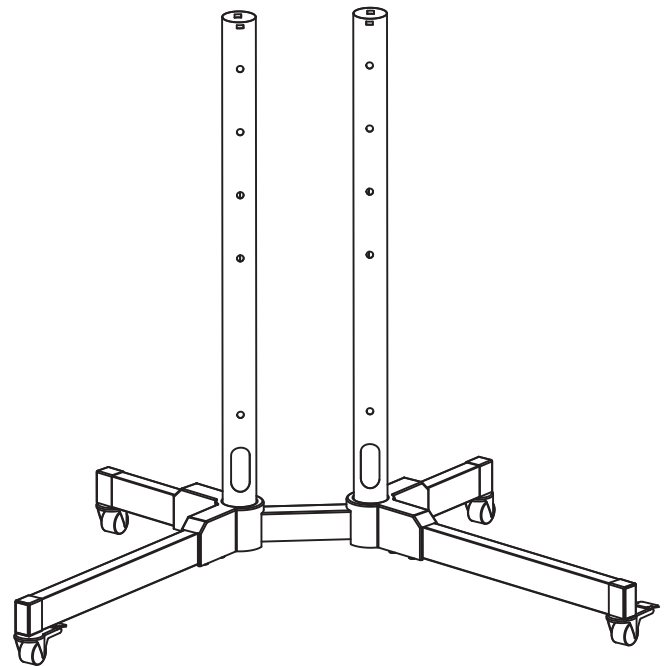

Step9

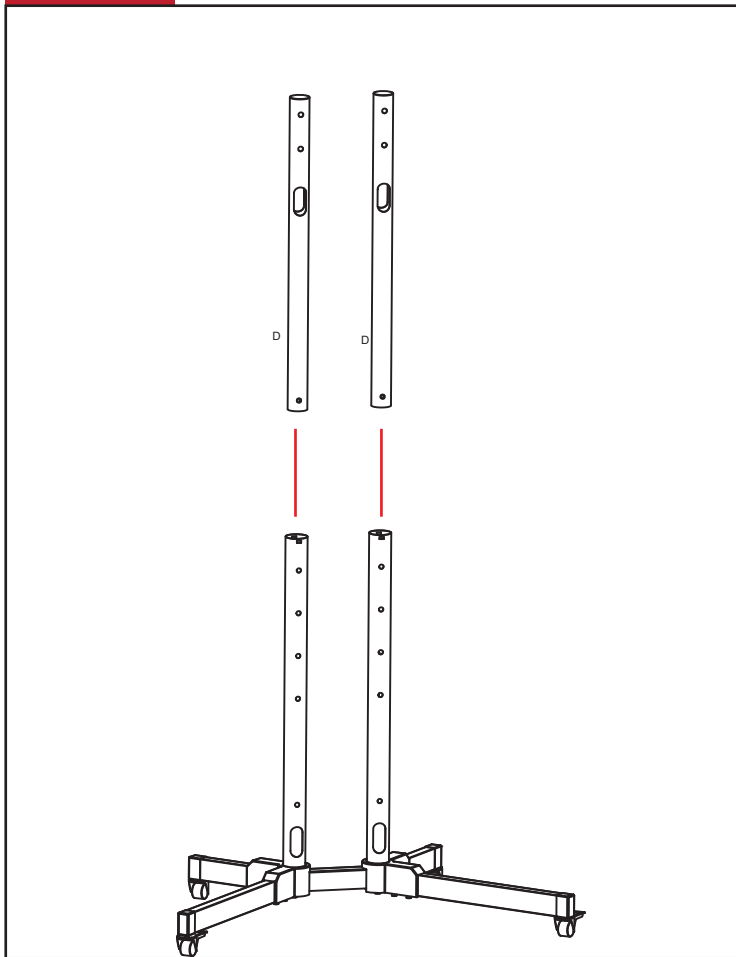

Step10

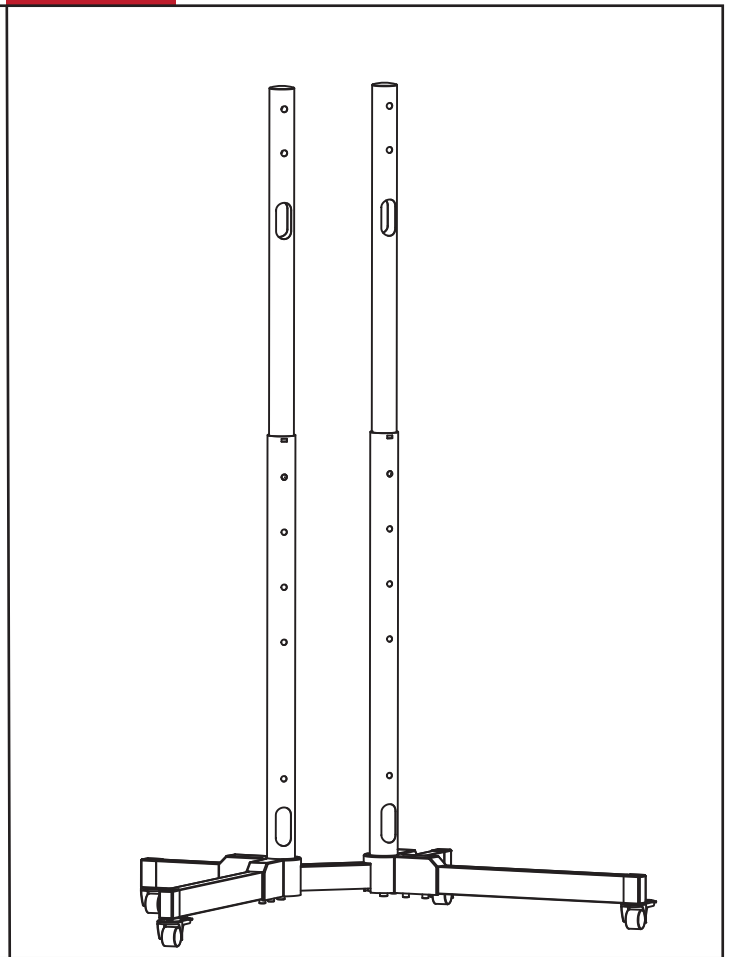

Step11

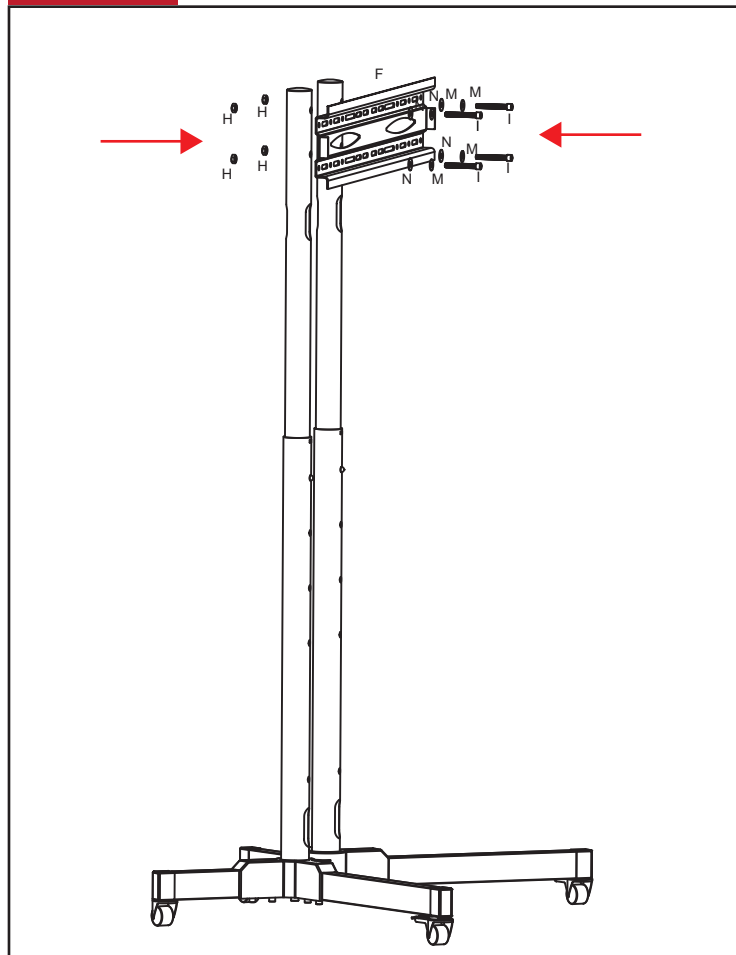

Step12

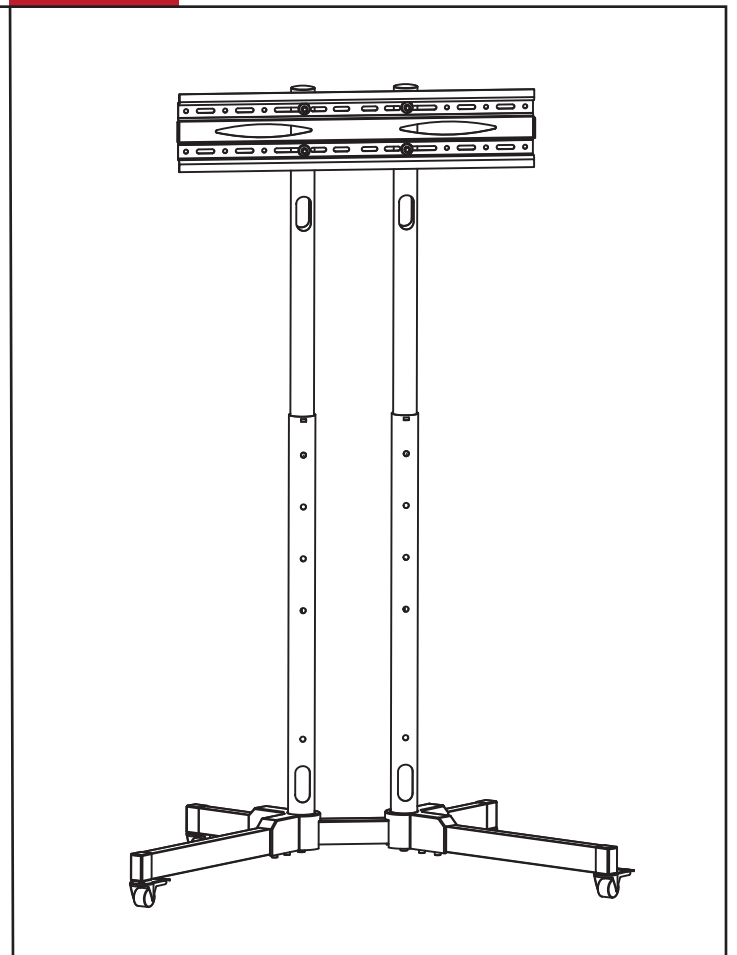

Step13

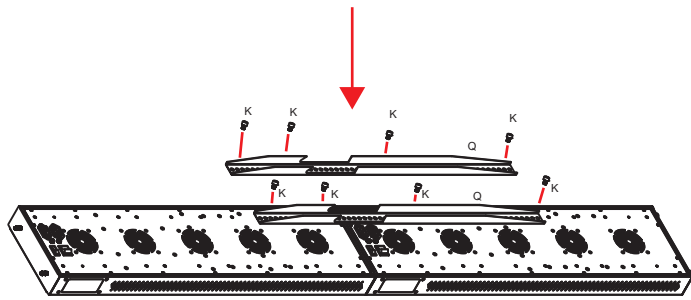

Step14



Step15

