



# EVERPURE® COLDRINK® 3-XCLM+ HIGH CAPACITY CHLORAMINES REDUCTION SYSTEM

HIGH CAPACITY QUICK-CHANGE CHLORAMINES REDUCTION SYSTEM FOR FOUNTAIN APPLICATIONS

Coldrink 3 -XCLM+ System: EV9761-23  
Replacement cartridge: EV9761-00



## APPLICATIONS

Fountain

## FEATURES • BENEFITS

A specialized carbon formulation maximizes the volume of activated carbon to provide a combination of optimal chloramines reduction with improved product life in a single cartridge

Superior filtration provides enhanced chlorine taste & odor reduction and filters dirt and particles as small as 5 microns in size

Protects drink system seals, pump, tubing and small orifices from clogging, corrosion and abrasive wear

20" prefilter reduces dirt and particulate.

Manifold features water shut-off, flushing valve, inlet and outlet pressure gauges

Reduces chloramines, chlorine taste & odor and other offensive contaminants that can adversely affect the taste of beverages

Improves the taste of fountain beverages and helps retain the drink's carbonation

NSF/ANSI Standard 42 certified

## INSTALLATION TIPS

Install vertically on flat surface with cartridges hanging down.

Allow 2½" (6.35 cm) clearance below the cartridges for easy cartridge replacement.

Flush cartridges by running water through system for five (5) minutes at full flow.

Refer to Installation and Operation Guide for cartridge flushing and start-up.

## OPERATION TIPS

Change cartridges on a regular one (1) year preventative maintenance program.

Always flush the filter cartridge at time of installation and cartridge change.

Change cartridges when capacity is reached or when pressure decreases.

## SIZING

Rated Capacity at Service Flow Rate:

27,900 gallons @ 6.00 gpm  
(105,612 L @ 22.71 Lpm)

34,800 gallons @ 5.01 gpm\*  
(131,732 L @ 18.96 Lpm\*)

57,900 gallons @ 3.00 gpm\*  
(219,175 L @ 11.35 Lpm\*)

\* Not Performance Tested or Certified by NSF.

# EVERPURE® COLDRINK® 3-XCLM+ HIGH CAPACITY CHLORAMINES REDUCTION SYSTEM

EV9761-23

## SPECIFICATIONS

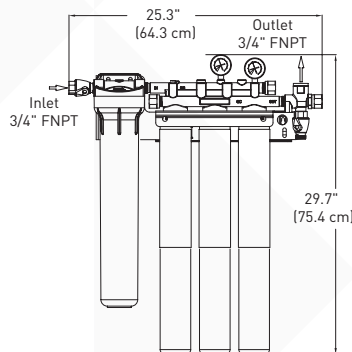

**Overall Dimensions**  
25.3" W x 6.0" D x 29.7" H  
(64.3 cm x 15.2 cm x 75.44 cm)

**Rated Capacity**  
27,900 gallons @ 6.00 gpm  
(105,612 L @ 22.71 Lpm)  
34,800 gallons @ 5.01 gpm\*  
(131,732 L @ 18.96 Lpm\*)  
57,900 gallons @ 3.00 gpm\*  
(219,175 L @ 11.35 Lpm\*)

\* Not Performance Tested  
or Certified by NSF.

**Pressure Requirements**  
10 - 125 psi (0.7 - 8.6 bar), non-shock

**Temperature**  
35 - 100°F (2 - 38°C)

**Electrical Connection**  
None required



System is Tested and Certified by NSF International against NSF/ANSI Standard 42 for the reduction of:  
STANDARD NO. 42 —  
AESTHETIC EFFECTS

Chemical Reduction  
Taste and Odor  
Chloramines  
Chlorine

Mechanical Filtration  
Nominal Particulate Reduction:  
Class III

The contaminants or other substances removed or reduced by this drinking water system are not necessarily in your water. Do not use with water that is microbiologically unsafe or of unknown quality without adequate disinfection before or after the system.

## WARRANTY

Everpure water treatment systems by Pentair® (excluding replaceable elements) are covered by a limited warranty against defects in material and workmanship for a period of five years after date of purchase. Everpure replaceable elements (filter cartridges and water treatment cartridges) are covered by a limited warranty against defects in material and workmanship for a period of one year after date of purchase. See printed warranty for details. Pentair will provide a copy of the warranty upon request.



### WATER QUALITY SYSTEMS

EVERPURE-SHURFLO WORLD HEADQUARTERS, 1040 MUIRFIELD DRIVE, HANOVER PARK, IL 60133 USA • FOODSERVICE.PENTAIR.COM  
800.942.1153 (US ONLY) • 630.307.3000 MAIN • 630.307.3030 FAX • CSEVERPURE@PENTAIR.COM EMAIL

EVERPURE-SHURFLO AUSTRALIA, 1-21 MONASH DRIVE, DANDENONG SOUTH, VIC 3175, AUSTRALIA  
011.1300.576.190 TEL • 011.61.39.562.7237 FAX • AU.EVERPURE@PENTAIR.COM EMAIL

EVERPURE-SHURFLO CHINA, 21F CLOUD 9 PLAZA, NO 1118, SHANGHAI, 200052, CHINA  
86.21.3211.4588 TEL • 86.21.3211.4580 FAX • CHINA.WATER@PENTAIR.COM EMAIL

EVERPURE-SHURFLO INDIA, GREEN BOULEVARD, B-9/A, 7TH FLOOR - TOWER B SECTOR 62, NOIDA - 201301  
91.120.419.9444 TEL • 91.120.419.9400 FAX • INDIACUSTOMER@PENTAIR.COM EMAIL

EVERPURE-SHURFLO EUROPE, PENTAIR WATER BELGIUM BVBA, INDUSTRIEPARK WOLFSTEE, TOEKOMSTLAAN, 30 B-2200 HERENTALS, BELGIUM  
+32.(0).14.283.500 TEL • +32.(0).14.283.505 FAX • SALES@EVERPURE-EUROPE.COM EMAIL

EVERPURE-SHURFLO JAPAN INC., HASHIMOTO MN BLDG. 7F, 3-25-1 HASHIMOTO, MIDORI-KU, SAGAMIHARA-SHI KANAGAWA 252-0143, JAPAN  
81.(0)42.775.3011 TEL • 81.(0)42.775.3015 FAX • INFO@EVERPURE.CO.JP EMAIL

EVERPURE-SHURFLO SOUTHEAST ASIA, SOUTHEAST ASIA, 390 HAVELOCK ROAD, #04-01 KING'S CENTRE, SINGAPORE 169662  
65.6768.5800 TEL • 65.6737.5149 FAX • CSEVERPURE@PENTAIR.COM EMAIL

All Pentair trademarks and logos are owned by Pentair, Inc. or its affiliates. All other registered and unregistered trademarks and logos are the property of their respective owners. Because we are continuously improving our products and services, Pentair reserves the right to change specifications without prior notice. Pentair is an equal opportunity employer.