



# EVERPURE® HFC-10 SYSTEM

## DELIMING SYSTEM FOR WAREWASHING EQUIPMENT

HFC-10 Deliming System: EV9100-91



### APPLICATIONS

- Commercial Dishwashers
- Commercial Glassware Washers
- Warewashing Booster Heaters

### FEATURES • BENEFITS

- Improves equipment efficiency, helps extend the life of equipment and reduces maintenance costs
- Provides simple, efficient deliming of commercial warewashing equipment
- Reduces limescale deposits which can cause equipment failure

- Uses ScaleKleen, Everpure's proprietary food-grade scale remover which is environmentally safe
- System includes; a heavy-duty housing, dip tube assembly, 2.2 lb ScaleKleen™ package and hardness test strip

### INSTALLATION TIPS

- System must be installed on inlet water line to equipment.
- Installing a bypass for delimiting is recommended.
- Use 1/2" water line.
- Install vertically using the mounting bracket provided.

### OPERATION TIPS

- Follow delimiting schedule as noted in operation manual.
- To determine water hardness and frequency of delimiting, follow instructions on hardness test strip package and compare to hours of operation.

### SIZING

- Service Flow Rate: Maximum 6 gpm (22.7 Lpm)

# EVERPURE® HFC-10 SYSTEM

## EV9100-91

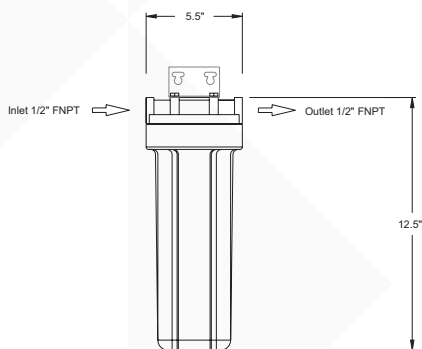

### SPECIFICATIONS

#### Service Flow Rate

Maximum 6 gpm (22.7 Lpm)

#### Pressure Requirements

10 – 125 psi (0.7 – 8.6 bar), non-shock

#### Temperature

160°F (94°C)

#### Overall Dimensions

12.5" L x 5.5" D (31.8 cm x 13.9 cm)

#### Inlet Connection

1/2"

#### Outlet Connection

1/2"

#### Operating Weight

10 lbs (4.5 kgs)

#### Shipping Weight

7 lbs (3.1 kgs)

#### Electrical Connection

None required

### WARRANTY

Everpure water treatment systems by Pentair® (excluding replaceable elements) are covered by a limited warranty against defects in material and workmanship for a period of five years after date of purchase. Everpure replaceable elements (filter cartridges and water treatment cartridges) are covered by a limited warranty against defects in material and workmanship for a period of one year after date of purchase. See printed warranty for details. Pentair will provide a copy of the warranty upon request.



#### WATER QUALITY SYSTEMS

EVERPURE-SHURFLO WORLD HEADQUARTERS, 1040 MUIRFIELD DRIVE, HANOVER PARK, IL 60133 USA • FOODSERVICE.PENTAIR.COM  
800.942.1153 MAIN (US ONLY) • 630.307.3000 MAIN • 630.307.3030 FAX • CSEVERPURE@PENTAIR.COM EMAIL

EVERPURE-SHURFLO AUSTRALIA, 1-21 MONASH DRIVE, DANDENONG SOUTH, VIC 3175, AUSTRALIA  
011.1300.576.190 TEL • 011.61.39.562.7237 FAX • AU.EVERPURE@PENTAIR.COM EMAIL

EVERPURE-SHURFLO CHINA, 21F CLOUD 9 PLAZA, NO 1118, SHANGHAI, 200052, CHINA  
86.21.3211.4588 TEL • 86.21.3211.4580 FAX • CHINA.WATER@PENTAIR.COM EMAIL

EVERPURE-SHURFLO INDIA, GREEN BOULEVARD, B-9/A, 7TH FLOOR - TOWER B SECTOR 62, NOIDA - 201301  
91.120.419.9444 TEL • 91.120.419.9400 FAX • INDIACUSTOMER@PENTAIR.COM EMAIL

EVERPURE-SHURFLO EUROPE, PENTAIR WATER BELGIUM BVBA, INDUSTRIEPARK WOLFSTEE, TOEKOMSTLAAN, 30 B-2200 HERENTALS, BELGIUM  
+32.(0).14.283.500 TEL • +32.(0).14.283.505 FAX • SALES@EVERPURE-EUROPE.COM EMAIL

EVERPURE-SHURFLO JAPAN INC., HASHIMOTO MN BLDG. 7F, 3-25-1 HASHIMOTO, MIDORI-KU, SAGAMIHARA-SHI KANAGAWA 252-0143, JAPAN  
81.(0)42.775.3011 TEL • 81.(0)42.775.3015 FAX • INFO@EVERPURE.CO.JP EMAIL

EVERPURE-SHURFLO SOUTHEAST ASIA, SOUTHEAST ASIA, 390 HAVELOCK ROAD, #04-01, KING'S CENTRE, SINGAPORE 169662  
65.6768.5800 TEL • 65.6737.5149 FAX • CSEVERPURE@PENTAIR.COM EMAIL

All Pentair trademarks and logos are owned by Pentair, Inc. or its affiliates. All other registered and unregistered trademarks and logos are the property of their respective owners. Because we are continuously improving our products and services, Pentair reserves the right to change specifications without prior notice. Pentair is an equal opportunity employer.