

QC71 Single - MH² System

Delivers premium quality water for coffee applications

EVERPURE[®]

APPLICATIONS

Coffee
High flow, higher
volume coffee urns.

FEATURES AND BENEFITS

Provides clear, fresh, premium quality ingredient water for consistently great tasting coffee and beverages.

New and improved Micro-Pure II media inhibits the growth of bacteria.

Everpure's unique filter blend using activated carbon reduces chlorine taste and odor and other offensive contaminants.

Saves energy by reducing scale build-up. Self-contained scale inhibitor feed dramatically prevents limescale from forming in brewing equipment.

Engineered to always feed the correct amount of scale inhibitor into each volume of water.

Precoat submicron technology reduces dirt and particles as small as 1/2 micron in size and reduces health contaminants such as cysts.

Sanitary cartridge replacement is simple, quick and clean.

NSF Certified under NSF/ANSI Standards 42 and 53.

OPERATIONAL TIPS

Change cartridges on a regular 6 month preventative maintenance program.

Change cartridges when capacity is reached or when pressure falls below 10 psi.

Service flow rate must not exceed 1.67 gpm.

Always flush the filter cartridge at time of installation and cartridge change.

Everpure water treatment systems (excluding replaceable elements) are covered by a limited warranty against defects in material and workmanship for a period of five years after date of purchase. Everpure replaceable elements (filter cartridges and water treatment cartridges) are covered by a limited warranty against defects in material and workmanship for a period of one year after date of purchase. See printed warranty for details. Everpure will provide a copy of the warranty upon request.



QC71 Filter Head: EV9272-41
MH² Cartridge: EV9613-21

SPECIFICATIONS

Overall Dimensions:	27.5" H x 5.6" W x 4" D (69.8 x 14.2 x 33.7 cm)
Inlet Connection:	3/8"
Outlet Connection:	3/8"
Service Flow Rate:	Maximum 1.67 gpm (6.3 Lpm)
Rated Capacity:	9,000 gallons (35,069 L) or 18,000 pots
Pressure Requirements:	10 – 125 psi (0.7 – 8.6 bar), non-shock
Temperature:	35 – 100°F (2 – 38°C)
Electrical Connection:	None
Shipping Weight:	6 lbs. (2.7 kg)
Operating Weight:	9 lbs. (4.1 kg)

QC71 Single - MH² System

QC71-MH²

INSTALLATION TIPS

Never use saddle valve for connection.

Use 3/8" water line.

Allow 2-1/2" clearance below the cartridge for easy cartridge replacement.

Flush MH² cartridge by running water through filter for three minutes at full flow.

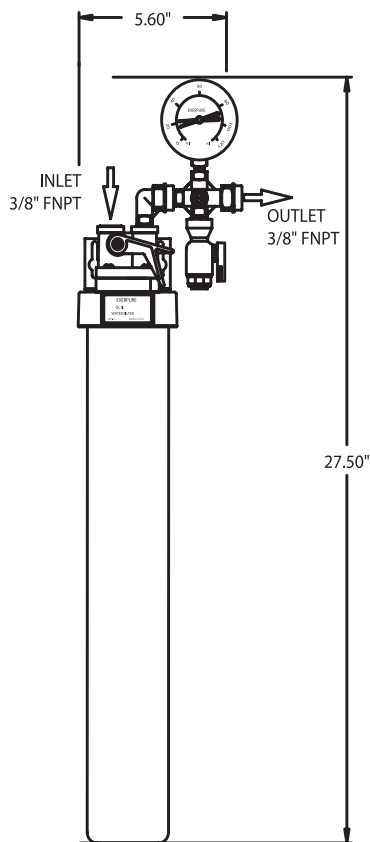

The contaminants or other substances removed or reduced by this drinking water system are not necessarily in your water. Do not use with water that is microbiologically unsafe or of unknown quality without adequate disinfection before or after the system. Systems certified for cyst reduction may be used with disinfected water that may contain filterable cysts.

EVERPURE reserves the right to update specifications, change prices, or make substitutions without notice.



System Tested and Certified by NSF International against NSF/ANSI Standard 42 and 53 for the reduction of:

- Standard No. 42: Aesthetic Effects
 - Chemical Unit
 - Taste and Odor Reduction
 - Chlorine Reduction
 - Mechanical Filtration Unit
 - Particulate Reduction, Class I
- Standard No. 53: Health Effects
 - Mechanical Filtration Unit
 - Turbidity Reduction
 - Cyst Reduction
 - Asbestos Reduction

EVERPURE

WATER YOU CAN TRUST®

Visit our website at www.everpure.com

Everpure-SHURflo India
Green Boulevard, B-9/A, 7th Floor -
Tower B Sector 62, Noida - 201301
TEL: 91.120.419.9444
FAX: 91.120.419.9400
EMAIL: indiacustomer@Pentair.com

Everpure-SHURflo Japan Inc.
Hashimoto MB Bldg. 7F
3-25-1 Hashimoto, Midori-ku
Sagamihara-Shi Kanagawa 252-0143
JAPAN
TEL: 81.(0)42.775.3011
FAX: 81.(0)42.775.3015
EMAIL: info@everpure.co.jp

Everpure-SHURflo China
21F Cloud 9 Plaza, No 1118
Shanghai, 200052
CHINA
TEL: 86.21.3211.4588
FAX: 86.21.3211.4580
EMAIL: China.Water@Pentair.com

Pentair Filtration Solutions, LLC
World Headquarters-Everpure/SHURflo
North and South America Sales
1040 Muirfield Dr.
Hanover Park, Illinois 60133
USA
TEL: 800.942.1153 (US only)
TEL: 630.307.3000
FAX: 630.307.3030
EMAIL: cseverpure@pentair.com

Everpure-SHURflo Australia
2 Redwood Drive
Notting Hill
Victoria, 3168
AUSTRALIA
TEL: 011.61.39.574.4000
FAX: 011.61.39.562.7237
EMAIL: au.everpure@pentair.com

Everpure-SHURflo Southeast Asia
18 Boon Lay Way
#04-110/111
TradeHub 21, 609966
SINGAPORE
TEL: 65.6795.2213
FAX: 65.6795.2219
EMAIL: cseverpure@pentair.com

Everpure-SHURflo Europe
Pentair Water Belgium bvba
Industriepark Wolfstee
Toekomstlaan 30 B-2200 Herentals
BELGIUM
TEL: +32.(0).14.283.500
FAX: +32.(0).14.283.505
EMAIL: sales@everpure-europe.com

QC71-MH² MR11