

# 2.3

## Molded Case Circuit Breakers

### Series C

2

#### Catalog Number Selection

This information is presented only as an aid to understanding catalog numbers. It is not to be used to build catalog numbers for circuit breakers or trip units.

#### MDL Frame with Thermal-Magnetic Trip Unit Technology

##### Thermal-Magnetic Breakers and Frame ①

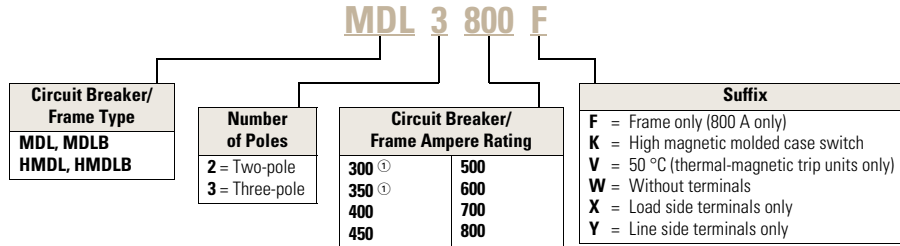

##### Thermal-Magnetic Trip Unit ①

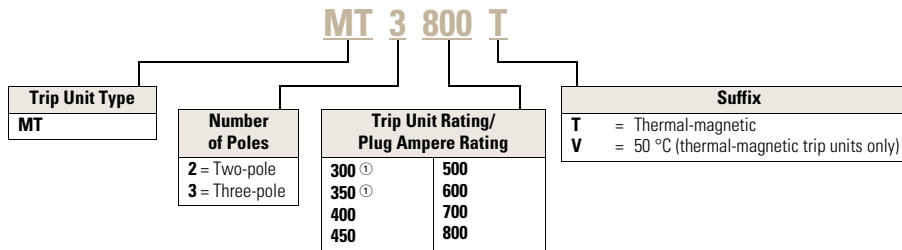

#### MDL Frame with 310+ Electronic Trip Unit Technology

##### 310+ Circuit Breaker

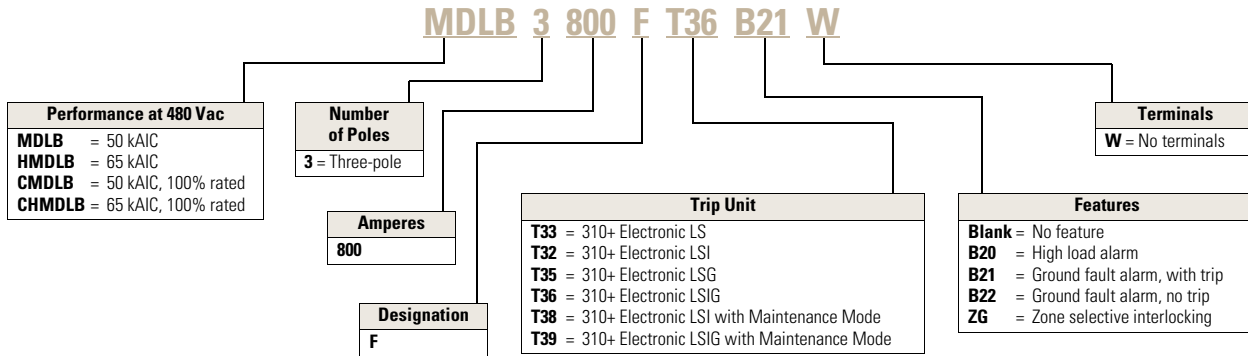

##### 310+ Electronic Trip Unit ①

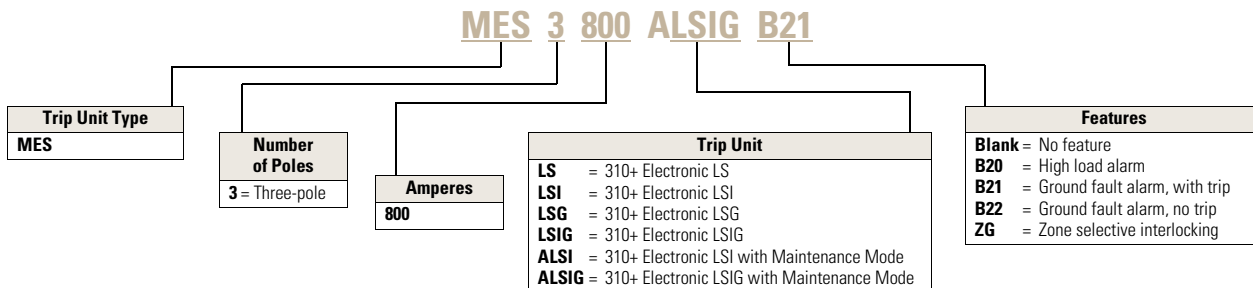

**Note**

① Frames are the same for thermal-magnetic or 310+ electronic trip units, e.g., MDL3800F, HMDL3800F, etc.

## HMDLDC3800F

**Type HMDLDC DC Circuit Breakers—  
Three-Pole High Interrupting Capacity 35 kAIC at 600 Vdc**

Maximum Continuous Ampere Rating at 40 °C	Circuit Breaker Frame Only <sup>①</sup> Catalog Number	Thermal-Magnetic Trip Unit Catalog Number	Standard Terminals Catalog Number
300	HMDLDC3800F	MT3300T	TA700MA1
350	HMDLDC3800F	MT3350T	TA700MA1
400	HMDLDC3800F	MT3400T	TA700MA1
450	HMDLDC3800F	MT3450T	TA700MA1
500	HMDLDC3800F	MT3500T	TA700MA1
600	HMDLDC3800F	MT3600T	TA700MA1
700	HMDLDC3800F	MT3700T	TA700MA1
800	HMDLDC3800F	MT3800T	TA800MA2

**Type NBDC DC Circuit Breakers—  
Three-Pole High Interrupting Capacity 50 kAIC at 600 Vdc**

Maximum Continuous Ampere Rating at 40 °C	Complete Circuit Breaker Factory Assembled without Terminals <sup>②</sup> Catalog Number	Includes Magnetic Trip Unit Calibrated at 135%	Standard Terminals Catalog Number
700	NBDC3700MW	Included	TA1000NB1
800	NBDC3800MW	Included	TA1000NB1
900	NBDC3900MW	Included	TA1000NB1
1000	NBDC31000MW	Included	TA1000NB1
1200	NBDC31200MW	Included	TA1200NB1

## RGHDC3300FFWM

**Type RGHDC DC Circuit Breakers—  
Three-Pole High Interrupting Capacity 65 kAIC at 600 Vdc**

Maximum Continuous Ampere Rating at 40 °C	Complete Circuit Breaker Factory Assembled <sup>②</sup>		Includes Magnetic Trip Unit Calibrated at 135%	Standard Rear Connectors Catalog Number
	Imperial Mounting Hardware Catalog Number	Metric Mounting Hardware Catalog Number		
1600	RGHDC3160FFWE	RGHDC3160FFWM	Included	B2016RDM
2000	RGHDC3200FFWE	RGHDC3200FFWM	Included	B2016RDM
2500	RGHDC3250FFWE	RGHDC3250FFWM	Included	B2500RDM
3000	RGHDC3300FFWE	RGHDC3300FFWM	Included	B3000RDM

**Notes**

<sup>①</sup> Includes frame and trip unit. Order terminals or connectors separately.

<sup>②</sup> Six rear connectors included as standard complete circuit breaker.