

2.2

Molded Case Circuit Breakers

Series G

Frames NG and RG

NG



RG



Maximum rated current (amperes)		800, 1200	800, 1200	800, 1200	1600 ^①	800	1600, 2000, 2500	1600, 2000, 2500	
Breaker type		S	H	C ^②	S	U	H	C ^②	
Number of poles		2, 3, 4	2, 3, 4	2, 3, 4	3	3	3, 4	3, 4	
Breaker Capacity (kA rms) AC 50–60 Hz									
NEMA, UL, CSA	240 Vac	85	100	200	—	200	125	200	
	480 Vac	50	65	100	—	150	65	100	
	600 Vac	25	35	65	—	65	50	65	
IEC 60947-2	220–240 Vac	I_{cu}	85	100	200	85	—	135	200
		I_{cs}	85	100	100	85	—	100	100
	380–415 Vac	I_{cu}	50	70	100	50	—	70	100
		I_{cs}	50	50	50	50	—	50	50
	660–690 Vac	I_{cu}	20 ^③	25 ^③	35	20 ^③	—	25 ^③	35 ^③
		I_{cs}	10	13	18	10	—	13	18
	250 Vdc	I_{cu}	—	—	—	—	—	—	—
		I_{cs}	—	—	—	—	—	—	—
Ampere range		400–1200 A	400–1200 A	400–1200 A	1600 A	800 A	800–2500 A	800–2500 A	
Trip units		Electronic (Digitrip RMS 310+)				Electronic (Digitrip RMS 310+ and 910)			
	Interchangeable	—	—	—	—	—	■ ^⑤	■ ^⑤	
	Built-in	■	■	■	■	■	■	■	
Electronic ^④	LI	—	—	—	—	—	■ ^⑥	■ ^⑥	
	LS	■	■	■	■	■	■	■	
	LSI	■	■	■	■	■	■	■	
	LIG	—	—	—	—	—	■ ^⑥	■ ^⑥	
	LSG	■	■	■	■	■	■	■	
	LSIG	■	■	■	■	■	■	■	
	ALSI	■	■	■	■	—	■	■	
	ALSIG	■	■	■	■	—	■	■	
Utilization category		A	A	A	A	A	A	A	

Notes

- ① NG 1600 ampere frame is not UL or CSA listed.
- ② Not KEMA-KEUR listed.
- ③ IEC 60947-2 H.5 Annex H is not KEMA-KEUR tested.
- ④ Not suitable for DC application. Four-pole ground fault not available.
- ⑤ RG 310+ are interchangeable with the exception of: FROM not ground fault equipped TO ground fault equipped
- ⑥ Available only on Digitrip 910 trip units.

General Specifications

All Series G Frames

	EG		JG		LG		NG		RG	
Maximum rated current I_n depending on the version	160 A ^①		250 A		400, 630 A ^②		800, 1200, 1600 A ^③		1600, 2000, 2500 A	
Rated insulation voltage U, according to IEC 60947-2										
Main conducting paths	500 Vac		750 Vac		750 Vac		750 Vac		750 Vac	
Auxiliary circuits	500 Vac		690 Vac		690 Vac		690 Vac		690 Vac	
Rated impulse withstand voltage U_{imp}										
Main conducting paths	6 kV		8 kV		8 kV		8 kV		8 kV	
Auxiliary circuits	4 kV		4 kV		4 kV		4 kV		4 kV	
Rated operational voltage U_g										
IEC	415 Vac		690 Vac		690 Vac		690 Vac		690 Vac	
NEMA	600Y/347 Vac		600 Vac		600 Vac		600 Vac		600 Vac	
UL and CSA listed	Yes ^①		Yes		Yes ^②		Yes ^③		Yes	
Permissible ambient temperature	-20 ° to 70 °C		-20 ° to 70 °C		-20 ° to 70 °C		-20 ° to 70 °C		-20 ° to 70 °C	
Permissible load for various ambient temperatures close to the circuit breaker, related to the rated current of the circuit breaker	④ ⑤		④ ⑤		④ ⑤		—		—	
Circuit breakers for plant protection										
At 40 °C	100%	100%	100%	100%	100%	100%	100%	100%	100%	100%
At 50 °C	96%	92%	96%	94%	96%	91%	91%	91%	91%	91%
At 55 °C	93%	87%	94%	90%	93%	86%	85%	85%	85%	85%
At 60 °C	91%	83%	92%	87%	90%	82%	81%	81%	81%	81%
At 70 °C	86%	73%	88%	80%	84%	70%	70%	70%	70%	70%
Circuit breakers for motor protection										
At 40 °C	—		100%		100%		—		—	
At 50 °C	—		100%		100%		—		—	
At 55 °C	—		100%		100%		—		—	
At 60 °C	—		100%		100%		—		—	
At 70 °C	—		90%		90%		—		—	
Circuit breakers for starter combinations and isolating circuit breakers										
At 40 °C	100%		100%		100%		100%		100%	
At 50 °C	100%		100%		100%		91%		91%	
At 55 °C	96%		96%		95%		85%		85%	
At 60 °C	91%		82%		90%		81%		81%	
At 70 °C	86%		88%		84%		—		—	
Rated short-circuit breaking capacity (DC) Not for circuit breakers for motor protection (Time constant $t = 10$ rms)										
Two conducting paths in series For EG to LG up to 250 Vdc	42 kA max.		42 kA max.		42 kA max.		⑥		⑥	
NEMA (time constant $t = 8$ rms) Two conducting paths in series 250 Vdc	42 kA max.		42 kA max.		42 kA max.		⑥		⑥	

Notes

- ① 125 amperes is the maximum UL and CSA rating for the EG.
- ② 630 amperes is not a UL or CSA listed rating. 600 amperes is the maximum UL and CSA rating for the LG.
- ③ 1200 amperes is the maximum UL and CSA rating for the NG.
- ④ Thermal overload release set to the lower value.
- ⑤ Thermal overload release set to the upper value.
- ⑥ Not suitable for DC switching.

All Series G Frames, continued

2

	EG	JG	LG	NG	RG	
Main switch characteristics according to IEC 60947-2 in combination with lockable rotary drives	Yes	Yes	Yes	Yes	Yes	
Rated short circuit breaking capacity according to IEC 60947-2 (at AC 50/60 Hz)	For rated short circuit breaking capacity, see Page V4-T2-9 .					
Endurance (operating cycles)	10,000	10,000	8,000	3,000	3,000	
Maximum switching frequency	300 1/h	240 1/h	240 1/h	60 1/h	60 1/h	
Conductor cross sections and terminal types for main conductors	Box terminals	Box terminals	Box terminals	Flat bar terminals	Flat bar terminals	Flat bar terminals
Solid or stranded	2.5 to 95 mm ²	50 to 150 mm ²	95 to 240 mm ²	—	—	—
Finely stranded with end sleeve	2.5 to 50/70 mm ²	35 to 120 mm ²	70 to 150 mm ²	—	—	—
Busbar	—	—	—	600 A	Optional	Optional
Tightening torque for box terminals	5.6 Nm	20 Nm	42 Nm	31 Nm	31 Nm	—
Tightening torque for busbar connection pieces	5.6 Nm	15 Nm	30 Nm	6 Nm	50 Nm	20 Nm
Conductor cross sections for auxiliary circuits with terminal connection or terminal strip						
Solid	0.75 to 2.5 mm ²	0.75 to 2.5 mm ²	0.75 to 2.5 mm ²	Up to 2x4 mm ²	Up to 2x4 mm ²	
Finely stranded with end sleeve	0.75 to 2.5 mm ²	0.75 to 2.5 mm ²	0.75 to 2.5 mm ²	Up to 2x2.5 mm ²	Up to 2x2.5 mm ²	
With brought-out cable ends	—	0.82 (AWG 18) mm ²	0.82 (AWG 18) mm ²	0.82 (AWG 18) mm ²	0.82 (AWG 18) mm ²	
Tightening torque for fitting screws	—	0.8 to 1.4 Nm	0.8 to 1.4 Nm	0.8 to 1.4 Nm	0.8 to 1.4 Nm	
Power loss per circuit breaker at maximum rated current I _n (the power losses of the undervoltage releases ("r" releases) must be observed if necessary) at three-phase symmetrical load)			400 A:	600 A:		
For plant protection	40 W	45 W	65 W	120 W	87/210 W	220/270/400 W
As isolating circuit breaker	40 W	45 W	65 W	120 W	87/210 W	220/270/400 W
For starter combinations	40 W	45 W	65 W	120 W	—	—
For motor protection	—	45 W	65 W	120 W	—	—
Permissible mounting position						
Arc spacing— suitable for reverse-feed applications	Yes (except HMCPE)	Yes	Yes	Yes	Yes	
Auxiliary Switches						
Rated thermal current I _{th}	6A	6A	6A	6A	6A	
Rated making capacity	20 A	20 A	20 A	20 A	20 A	
	AC-14	AC-14	AC-14	AC-15	AC-15	
Rated operational voltage	230/400/600 V	230/400/600 V	230/400/600 V	600 V	600 V	
Rated operational current	6/3/0.25 A	6/3/0.25 A	6/3/0.25 A	6A	6A	
				DC-13	DC-13	
Rated operational voltage	125/250V	125/250V	125/250V	125/250V	125/250V	
Rated operational current	0.5/0.15 A	0.5/0.15 A	0.5/0.15 A	0.5/0.25 A	0.5/0.25 A	
Backup fuse	6/4/4 A	(4) 6/4/4 A	(4) 6/4/4 A	(4) 6/4/4 A	(4) 6/4/4 A	
Miniature circuit breaker	6/4 A	6/4 A	6/4 A	6/4 A	6/4 A	

All Series G Frames, continued

	EG	JG	LG	NG	RG
Releases					
Undervoltage releases ("r" releases)					
Response voltage:					
Drop (breaker tripped) U_s	35–70%	35–70%	35–70%	35–70%	35–70%
Pickup (breaker may be switched on) U_s	85–110%	85–110%	85–110%	85–110%	85–110%
Power consumption in continuous operation at:					
50/60 Hz 12 Vac	—	—	—	1.9 VA	2.9 VA
50/60 Hz 24 Vac	0.72 VA	3.9 VA	3.9 VA	2.4 VA	3.1 VA
50/60 Hz 48–60 Vac	1.15–1.78 VA	2.5–3.8 VA	2.5–3.8 VA	2.3–4.1 VA	3.4–6.0 VA
50/60 Hz 110–127 Vac	0.96–1.25 VA	1.8–2.4 VA	1.8–2.4 VA	3.4–4.2 VA	3.3–3.8 VA
50/60 Hz 208–240 Vac	1.28–1.68 VA	2.7–3.8 VA	2.7–3.8 VA	4.8–6.5 VA	4.2–7.2 VA
50/60 Hz 380–500 Vac	2.2–3.9 VA	3.4–5.8 VA	3.4–5.8 VA	6.8–12.0 VA	3.8–10.0 VA
50/60 Hz 525–600 Vac	3.4–4.3 VA	3.4–4.3 VA	3.4–4.3 VA	—	—
12 Vdc	—	—	—	2.6W	3.4W
24 Vdc	0.70 W	3.1W	3.1W	3.6W	4.3W
48–60 Vdc	1.12–1.76W	2.0–3.1W	2.0–3.1W	3.5–5.5W	4.8–7.2W
110–125 Vdc	0.94–1.21W	1.6–2.2W	1.6–2.2W	2.9–3.6W	3.3–3.8W
220–250 Vdc	1.45–1.86W	3.1–4W	3.1–4W	4.8–6.3W	6.6–7.5W
Maximum opening time	50 ms	50 ms	50 ms	62 ms	62 ms
Shunt Trips					
Shunt trips ("f" releases)					
Response voltage:					
Pickup (breaker tripped) U_s	70–110%	70–110%	70–110%	70–110%	70–110%
Power consumption in (short time) at:					
50/60 Hz 24 Vac	10–41 VA	87–405 VA	87–405 VA	98–475 VA	612 VA
50/60 Hz 48–60 Vac	139–210 VA	710–1105 VA	710–1105 VA	24–50 VA	403–666 VA
50/60 Hz 48–127 Vac	—	—	—	—	—
50/60 Hz 110–240 Vac	83–360 VA	66–432 VA	66–432 VA	67–432 VA	396–1896 VA
50/60 Hz 380–440 Vac	—	127–188 VA	127–188 VA	76–110 VA	1596–2156 VA
50/60 Hz 380–600 Vac	418–1080 VA	—	—	—	—
50/60 Hz 480–600 Vac	—	34–60 VA	34–60 VA	19–42 VA	230–384 VA
12–24 Vdc	29–120 W	164–631 W	164–631 W	145–610 W	396 W
48–60 Vdc	475–720 W	830–1580 W	830–1580 W	67–102 W	341–528 W
110–125 Vdc	99–121 W	112–150 W	112–150 W	121–150 W	264–350 W
220–250 Vdc	—	40–58W	40–58 W	46–55 W	374–475 W
Maximum load duration	Interrupts automatically	Interrupts automatically	Interrupts automatically	Interrupts automatically	Interrupts automatically
Maximum opening time	50 ms	50 ms	50 ms	62 ms	62 ms
Molded Case Switch (with High Magnetic Trip)					
Unfused kAIC at 480 Vac (415 Vac)	65 (70)	65 (70)	65 (70)	65 (70)	65 (70)
Self-protected, will trip above	1250 for EG125; 1600 for EG160	2500	4000/6300	12,500	20,000



2.2

Molded Case Circuit Breakers

Series G

Dimensions and Weights

Approximate Dimensions in Inches (mm)

2

Series G—Frame EG, JG and LG

	EG			JG			LG		
	H	W	D	H	W	D	H	W	D
Single-pole	5.50 (139.7)	1.00 (25.4)	2.99 (76.0)	—	—	—	—	—	—
Two-pole	5.50 (139.7)	2.00 (50.8)	2.99 (76.0)	7.00 (177.8)	4.13 (105.0)	3.57 (87.4)	—	—	—
Three-pole	5.50 (139.7)	3.00 (76.2)	2.99 (76.0)	7.00 (177.8)	4.13 (105.0)	3.57 (87.4)	10.13 (258.0)	5.48 (140.0)	4.09 (104.0)
Four-pole	5.50 (139.7)	4.00 (101.6)	2.99 (76.0)	7.00 (177.8)	5.34 (135.6)	3.57 (87.4)	10.13 (258.0)	7.22 (183.0)	4.09 (104.0)

Series G—Frame NG and RG

	NG			RG		
	H	W	D	H	W	D
Single-pole	—	—	—	—	—	—
Two-pole	—	—	—	—	—	—
Three-pole	16.00 (406.0)	8.25 (210.0)	5.50 (140.0)	16.00 (406.0)	15.50 (394.0)	9.75 (229.0)
Four-pole	16.00 (406.0)	11.13 (280.0)	5.50 (140.0)	16.00 (406.0)	20.00 (508.0)	9.75 (229.0)

Approximate Shipping Weight in Lbs (kg)

Series G—Frame EG, JG and LG

	EG	JG	LG	NG	RG
Single-pole	0.85 (0.39)	—	—	—	—
Two-pole	1.57 (0.71)	11.3 (5.13)	—	—	—
Three-pole	2.28 (1.04)	5.06 (2.30) T/M 5.31 (2.41) ETU	12.36 (5.61) T/M 13.04 (5.92) ETU	46.8 (21.3)	103.0 (47.0)
Four-pole	2.85 (1.29)	6.76 (3.07) T/M 7.12 (3.23) ETU	16.27 (7.39) T/M 16.92 (7.68) ETU	62.0 (28.3)	118.4 (54.0)

RG-Frame (800–2500 Amperes)

2



Contents

<i>Description</i>	<i>Page</i>
EG-Frame (15–125 Amperes)	V4-T2-15
JG-Frame (63–250 Amperes)	V4-T2-29
LG-Frame (250–630 Amperes)	V4-T2-47
NG-Frame (320–1200 Amperes)	V4-T2-65
RG-Frame (800–2500 Amperes)	
Catalog Number Selection	V4-T2-75
Product Selection	V4-T2-76
Accessories	V4-T2-81
Technical Data and Specifications	V4-T2-82
Dimensions and Weights	V4-T2-84
Motor Circuit Protectors (MCP)	V4-T2-85
Motor Protector Circuit Breakers (MPCB)	V4-T2-89
30 mA Ground Fault (Earth Leakage) Module	V4-T2-92
Current Limiting Circuit Breaker Module	V4-T2-96
High Instantaneous Circuit Breaker for	
Selective Coordination	V4-T2-101
Special Features and Accessories	V4-T2-104
Motor Operators	V4-T2-112
Plug-In Blocks	V4-T2-114
Drawout Cassette	V4-T2-115

RG-Frame (800–2500 Amperes)

Product Description

- Eaton's RG-Frame circuit breakers are available as frame (which includes trip unit), rating plug and terminals
- All R-Frame circuit breakers are suitable for reverse feed use

Catalog Number Selection

This information is presented only as an aid to understanding catalog numbers. It is not to be used to build catalog numbers for circuit breakers or trip units.

70 kA at 415 Vac and 65 kA at 480 Vac

RG Circuit Breaker With 310+ Electronic Trip Unit

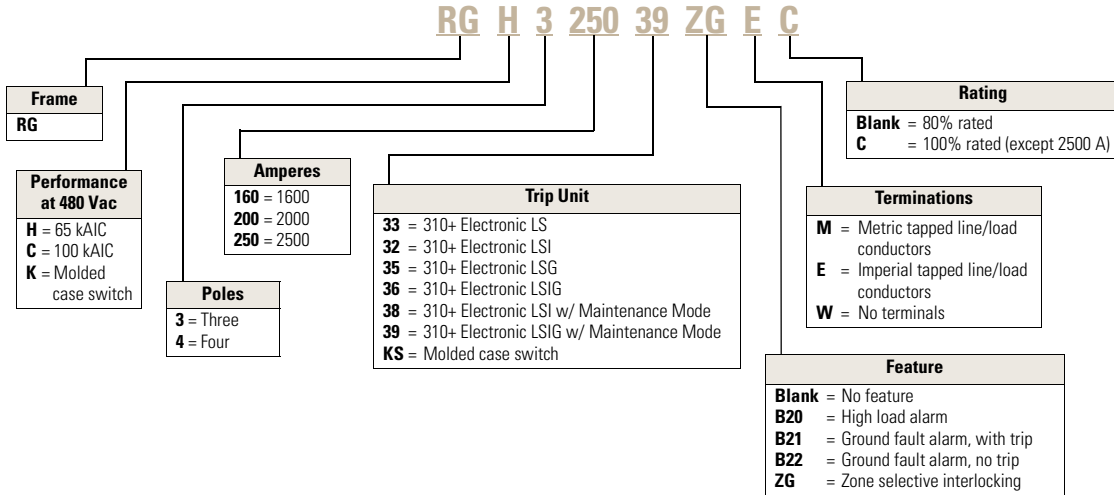

RG 310+ Electronic Trip Unit

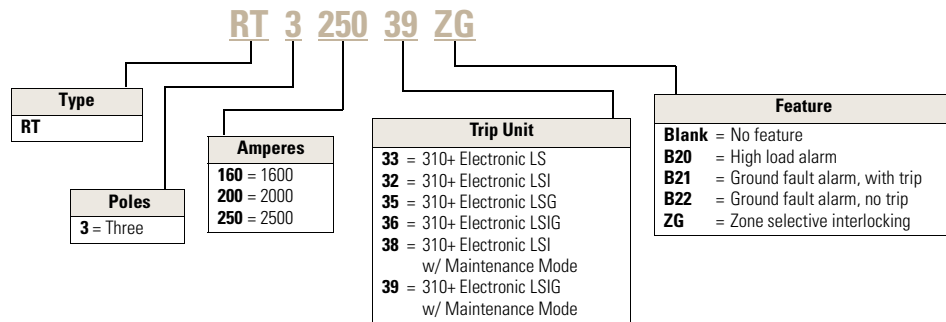

RG Circuit Breaker with OPTIM 610 and 910 Electronic Trip Unit

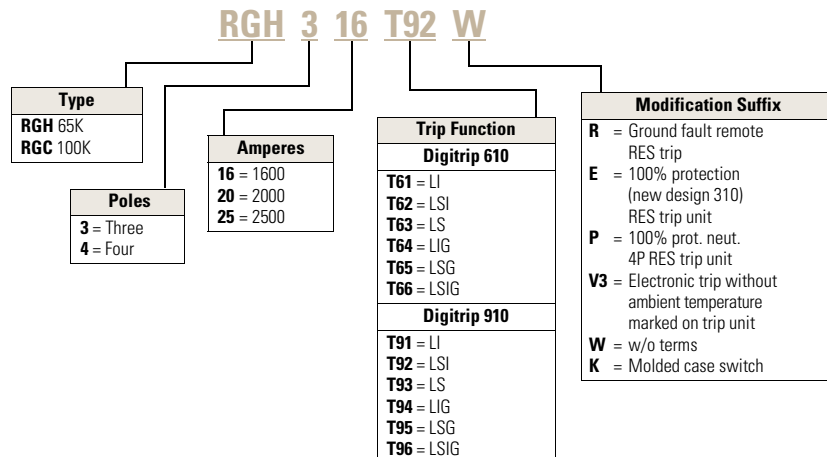

Technical Data and Specifications

2

UL 489/CSA Interrupting Capacity Ratings ^①

Circuit Breaker Type	Number of Poles	Interrupting Capacity (kA Symmetrical Amperes)			
		Volts AC (50/60 Hz)			
		240	277	480	600
RGH	3, 4	125	—	65	50
RGC	3, 4	200	—	100	65

IEC 947-2 Interrupting Capacity Ratings ^①

Circuit Breaker Type	Number of Poles	Interrupting Capacity (kA Symmetrical Amperes)		
		Volts AC (50/60 Hz)		
		240	415	690
RGH	3, 4			
I_{cu}		135	70	25
I_{cs}		100	50	13
RGC	3, 4			
I_{cu}		200	100	35
I_{cs}		100	50	18

RG 310+ Specifications

Description	Specification
Trip Unit Type	Digitrip RMS 310+
Breaker Type	
Frame designation	RG
Frames available	1600 A, 2000 A, 2500 A
Continuous current range (A)	800–2500 A
Ground fault pickup (A)	200–1200 A
Interrupting capacities at 480 Vac (kAIC)	65, 100
100% rated	Yes
Protection	
Ordering options	LS, LSI, LSG, LSIG, ALSI, ALSIG
Arcflash reduction maintenance system (or maintenance mode)	Yes
Interchangeable trip unit	Yes
High load alarm (suffix B20) ^②	Yes
Ground fault alarm with trip (suffix B21) ^②	Yes
Ground fault alarm, no trip (suffix B22) ^②	Yes
Zone selective interlocking (suffix ZG)	LSI, LSIG, ALSI, ALSIG
Cause of trip indication	Yes
Thru-cover accessories	No

Notes

^① Utilization Category A circuit breakers.

^② B2x suffixes cannot be combined with B2x suffixes.

See **Page V4-T2-74** for trip unit specifications.

RG 310+ Adjustability Specifications

310+ Settings		RG Frame		
		1600 A	2000 A	2500 A
I_r = continuous current or long delay pickup (amperes) (All 310+)	I_r			
	A	800	1000	1600
	B	900	1200	1700
	C	1000	1400	1800
	D	1100	1600	2000
	E	1200	1700	2100
	F	1400	1800	2200
	G	1500	1900	2400
	H (= I_n)	1600	2000	2500
t_r = long delay time (seconds) (All 310+)	Position 1	2	2	2
	Position 2	4	4	4
	Position 3	7	7	7
	Position 4	10	10	10
	Position 5	12	12	12
	Position 6	15	15	15
	Position 7	20	20	20
	Position 8	24	24	24
I_{sd} ($\times I_r$) = short delay pickup (All 310+)	Position 1	2x	2x	2x
	Position 2	3x	3x	2x
	Position 3	4x	4x	2x
	Position 4	5x	5x	3x
	Position 5	6x	6x	4x
	Position 6	7x	7x	5x
	Position 7	8x	8x	6x
	Position 8	8x	8x	6x
	Position 9	9x	9x	6x
t_{sd} = short delay time I^2t (milliseconds) (LS, LSG)	Fixed	67 at10x	67 at10x	67 at10x
t_{sd} = short delay time flat (milliseconds) (LSI, LSIG, ALSI, ALSIG) ①	Position 1	Inst	Inst	Inst
	Position 2	120	120	120
	Position 3	300	300	300
I_g = ground fault pickup (amperes) (LSG, LSIG, ALSIG)	Position 1	200	200	200
	Position 2	400	400	400
	Position 3	600	600	600
	Position 4	800	800	800
	Position 5	1000	1000	1000
	Position 6	1200	1200	1200
t_g = ground fault delay time (milliseconds) (LSG, LSIG, ALSIG)	Position 1	Inst	Inst	Inst
	Position 2	120	120	120
	Position 3	300	300	300
Independently Adjustable Instantaneous (I_i) setting (ALSI, ALSIG)	Yes	2.5x, 4x, 6x, 7x, 8x, 11x	2.5x, 4x, 6x, 7x, 8x, 9x	2.5x, 4x, 6x, 7x
Maintenance Mode (remote) pickup ($2.5 \times I_n$) (ALSI, ALSIG) ②	Fixed	2.5x	2.5x	2.5x

Notes

- ① 50 ms for ALSI and ALSIG trip units.
- ② Maintenance Mode is enabled remotely using a 24 Vdc circuit.

2.2

Molded Case Circuit Breakers

Series G

Dimensions and Weights

Approximate Dimensions in Inches (mm)

2

RG-Frame

Number of Poles	Width	Height	Depth
3	15.50 (393.7)	16.00 (406.4)	9.75 (247.7)
4	20.00 (508.0)	16.00 (406.4)	9.75 (247.7)

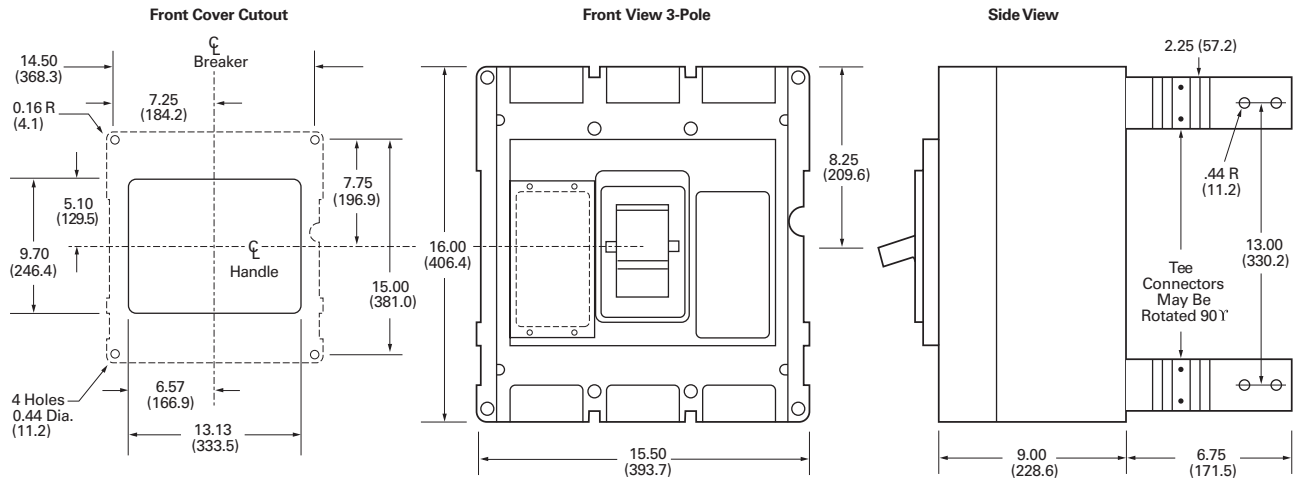

Approximate Shipping Weight in Lbs (kg)

RG-Frame

Breaker Type	Complete Breaker	
	Number of Poles Three-Pole	Four-Pole
1600 Amperes		
RGH, RGC	102 (46.3)	135 (61.2)
2000 Amperes		
RGH, RGC	102 (46.3)	135 (61.2)
2500 Amperes		
RGH, RGC	135 (61.2)	182 (82.6)