

Typical L-Frame Circuit Breaker



Contents

<i>Description</i>	<i>Page</i>
Product Overview	V4-T2-220
Standards and Certifications	V4-T2-221
Quick Reference	V4-T2-222
G-Frame (15–100 Amperes)	V4-T2-225
F-Frame (10–225 Amperes)	V4-T2-239
J-Frame (70–250 Amperes)	V4-T2-257
K-Frame (70–400 Amperes)	V4-T2-265
L-Frame (125–600 Amperes)	
Catalog Number Selection	V4-T2-290
Product Selection	V4-T2-292
Accessories	V4-T2-308
Technical Data and Specifications	V4-T2-310
Dimensions and Weights	V4-T2-314
M-Frame (300–800 Amperes)	V4-T2-315
N-Frame (400–1200 Amperes)	V4-T2-326
R-Frame (800–2500 Amperes)	V4-T2-341
Motor Circuit Protectors (MCP)	V4-T2-360
Motor Protection Circuit Breakers (MPCB)	V4-T2-371
Type ELC Current Limiter Attachment (Size 0–4)	V4-T2-373
Current Limiting Circuit Breaker Module	V4-T2-374
Internal Accessories	V4-T2-377
External Accessories	V4-T2-410

L-Frame (125–600 Amperes)

Product Description

- All Eaton L-Frame circuit breakers are HACR rated
- L-Frame circuit breakers are available as individual components (frame, trip unit, terminals), or factory assembled complete breakers
- L-Frame circuit breakers with non-interchangeable trip units are suitable for reverse feed use

Standards and Certifications

- CE marked



2.4

Molded Case Circuit Breakers

Series C

2

Catalog Number Selection

This information is presented only as an aid to understanding catalog numbers. It is not to be used to build catalog numbers for circuit breakers or trip units.

LD-Frame with Thermal-Magnetic Trip Unit Technology

Thermal-Magnetic Breakers and Frame ①

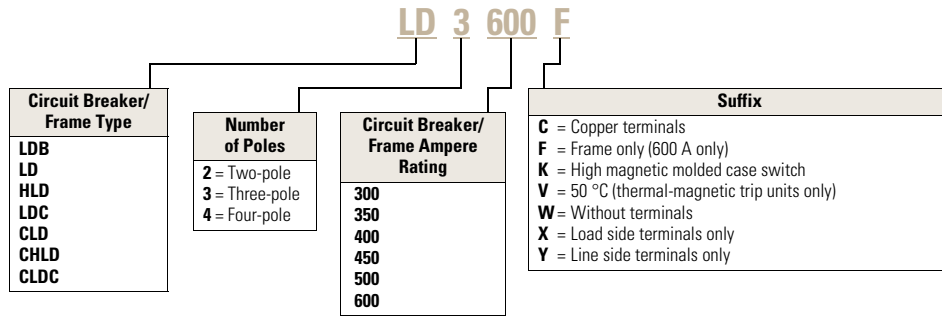

Thermal-Magnetic Trip Unit ①

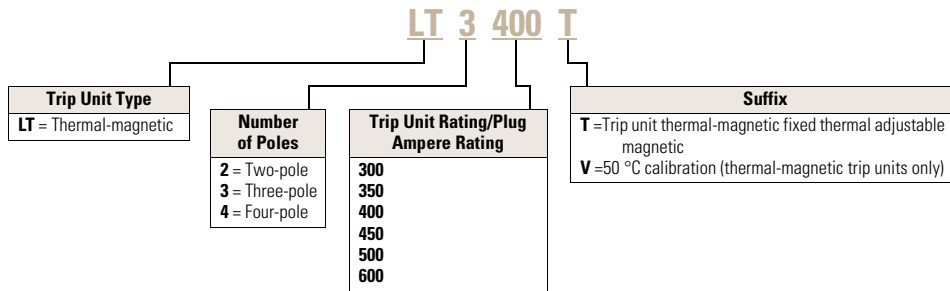

Note

① Frames are the same for thermal-magnetic or 310+ electronic trip units, e.g., **LD3600F**, **HLD3600F**, etc.