



Installation Instruction for Cutler-Hammer LDB, LD, HLD, HLDB, LDCB, LDC, LW, HLW, LWC, CLD, CHLD, CLDC Circuit Breakers and L-Frame Series C Molded Case Switches



WARNING

CONTACT WITH ENERGIZED EQUIPMENT CAN RESULT IN DEATH, SEVERE PERSONAL INJURY, OR SUBSTANTIAL PROPERTY DAMAGE. DO NOT ATTEMPT TO INSTALL OR PERFORM MAINTENANCE ON EQUIPMENT WHILE IT IS ENERGIZED. ALWAYS VERIFY THAT NO VOLTAGE IS PRESENT BEFORE PROCEEDING WITH THE TASK, AND ALWAYS FOLLOW GENERALLY ACCEPTED SAFETY PROCEDURES.

CUTLER-HAMMER IS NOT LIABLE FOR THE MISAPPLICATION OR MISINSTALLATION OF ITS PRODUCTS.

The user is cautioned to observe all recommendations, warnings, and cautions relating to the safety of personnel and equipment as well as all general and local health and safety laws, codes, and procedures. The recommendations and information contained herein are based on Cutler-Hammer experience and judgement, but should not be considered to be all-inclusive or covering every application or circumstance which may arise. If any questions



Fig. 1-1 L-Frame Model D Series C Circuit Breaker Frame with LT Trip Unit Installed

arise, contact Cutler-Hammer for further information or instructions.

1. INTRODUCTION

General Information

The L-frame Series C circuit breaker (Fig. 1-1) types LD, HLD, and LDC are 600 Vac maximum rated devices with interchangeable thermal-magnetic or electronic DIGI-TRIP RMS trip units rated 600A maximum continuous current. The type LDB circuit breaker uses noninterchangeable trip units and is factory sealed. Circuit breaker types LW, HLW, and LWC are 690 Vac maximum rated devices with interchangeable adjustable thermal/adjustable magnetic or electronic trip units rated up to 630A continuous current. Refer to Table 1-1 for all available trip unit ratings. Model D circuit breakers are listed in accordance with Underwriters Laboratories, Inc. Standard UL 489 and satisfy the requirements of the International Electrotechnical Commission Recommendations No. IEC 947-2. Model W circuit breakers satisfy the requirements of IEC 947-2. Molded case switches are listed in accordance with UL 1087. For more information, see Selection Data 29-120L.

This instruction leaflet (IL) gives procedures for installation and field testing of L-frame Series C circuit breakers. For this publication, the term circuit breaker shall also include the molded case switch.

100 Percent Rated L-Frame Circuit Breakers

CLD, CHLD, and CLDC circuit breakers are suitable for continuous operation at 100 percent of the frame rating if used with 90°C insulated wire and AL9CU terminals in an enclosure which measures at least 24" high x 15" wide x 6" deep. The minimum required ventilation is 8 sq. in. top front and 8 sq. in. bottom front.

2. INSTALLATION

The installation procedure consists of inspecting the circuit breaker and, as applicable, installing the trip unit and rating plug, accessories, and terminals; mounting the circuit breaker; connecting the line and load conductors; torquing terminals; and attaching terminal shields. Circuit breaker frames, trip units, rating plugs, accessories, mounting hardware, and unmounted terminals may be

supplied in separate packages. To install the circuit breaker, perform the following steps.

Note: LDB circuit breakers are factory sealed for reverse feed applications under UL 489. UL requires that internal accessories be installed at the factory in these types of circuit breakers.

Internal accessory installation in any type of circuit breaker should be done before the circuit breaker is mounted and connected. Refer to individual accessory instruction leaflets for specific installation instructions on field installable accessories.

2-1. Compare nameplate data with existing equipment ratings and system requirements to make sure that the circuit breaker is suitable for the intended installation. Prior to mounting, confirm that the circuit breaker has not been damaged during transit or initial handling.

2-2. To install trip unit and any internal accessories, remove installed cover screws and cover.

Note: The circuit breaker handle must be in the tripped or OFF position to remove the cover. Instructions for installing the trip unit and accessories are supplied with the devices.

2-3. If not already installed, mount trip unit and accessories (if required) in circuit breaker frame. Rating plug must be installed in electronic trip units.

Note: When required to be removed or replaced, stationary interphase barriers can only be installed or removed with circuit breaker in the tripped or open position.

2-4. After the trip unit and any internal accessories are installed, and with the circuit breaker in the tripped position, make sure that stationary interphase barriers are properly installed in base. Install cover and secure with pan-head screws. Eight screws are used for two and three pole circuit breakers. Ten screws are used for four pole circuit breakers. Torque to 20-22 lb-in (2.26-2.49 N.m).

2-5. If not already installed, mount wire connecting terminals as shown in Fig. 2-1. Secure the terminals to the circuit breaker using two pan-head slotted screws and lockwashers. Torque to 6 to 8 lb-ft (8.14 to 10.85 N.m). With the circuit breaker mounted and before the conductors are installed and conductor clamping screws inserted, the terminal

mounting screws may be checked for correct torque.



WARNING

THE VOLTAGES IN ENERGIZED EQUIPMENT CAN CAUSE DEATH OR SEVERE PERSONAL INJURY. BEFORE MOUNTING THE CIRCUIT BREAKER IN AN ELECTRICAL SYSTEM, MAKE SURE THERE IS NO VOLTAGE PRESENT WHERE WORK IS TO BE PERFORMED. SPECIAL ATTENTION SHOULD BE PAID TO REVERSE FEED APPLICATIONS TO ENSURE NO VOLTAGE IS PRESENT.

Note: Depending on the equipment configuration, the circuit breaker can be mounted using different styles of hardware. The following steps describe how to mount the circuit breaker using standard hardware. When special hardware is needed (for example, with the motor operator), the instruction leaflet describing the accessory also describes the special mounting arrangements.

2-6. To mount the circuit breaker, perform the following steps:

- a. For individual surface mounting, drill mounting panel using the drilling plan shown in Fig. 2-2. For panelboard mounting, only load end support mounting holes are required. For deadfront cover applications, cut out cover to correct escutcheon dimensions, see Fig. 2-3.
- b. If circuit breaker includes factory or field installed internal accessories, make sure accessory wiring is accessible when the circuit breaker is mounted.

Note: Labels with accessory connection schematic diagrams are provided on the side of the circuit breaker.

- c. Position circuit breaker on mounting surface.
- d. Install circuit breaker mounting screws and washers. Tighten screws firmly, but do not exceed 28 lb-in (3 N.m.).

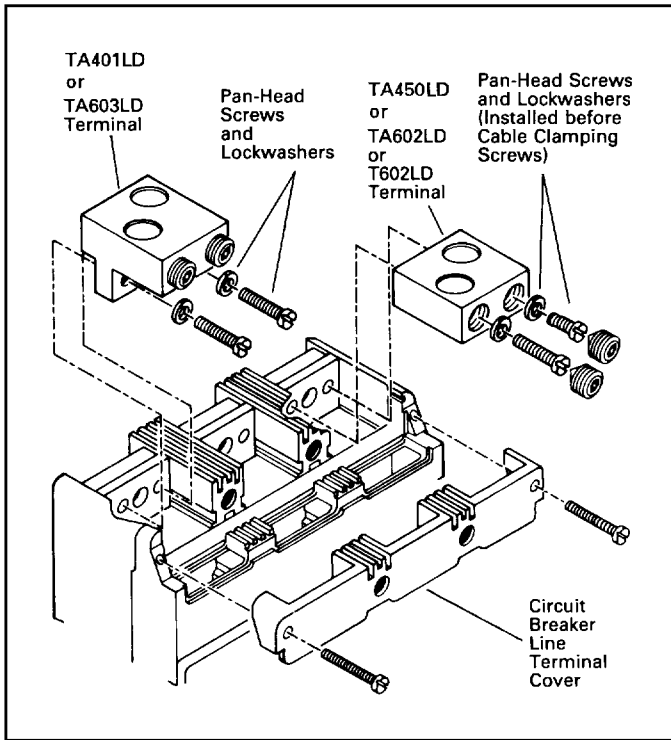

Fig. 2-1 Terminal Installation

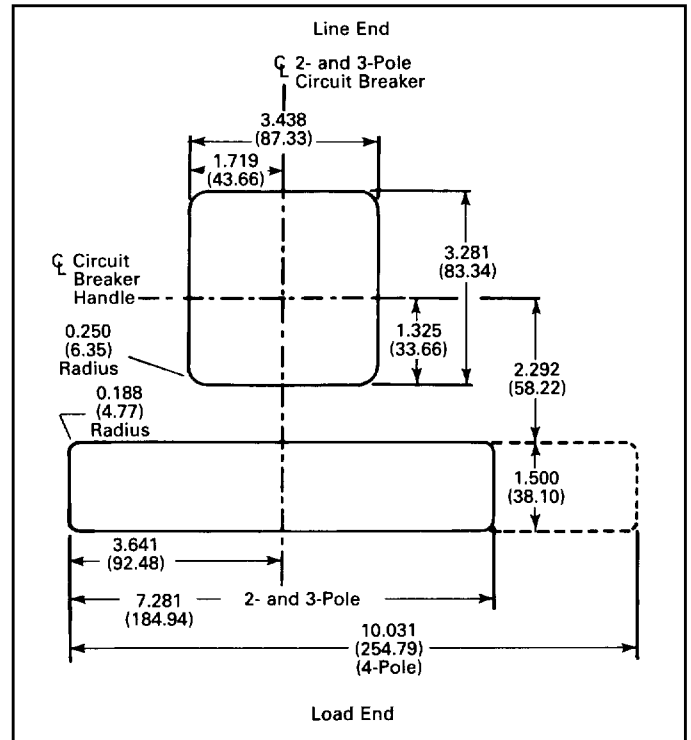

Fig. 2-3 Circuit Breaker Escutcheon Cutout Dimensions for 2-, 3-, and 4-Pole Circuit Breakers

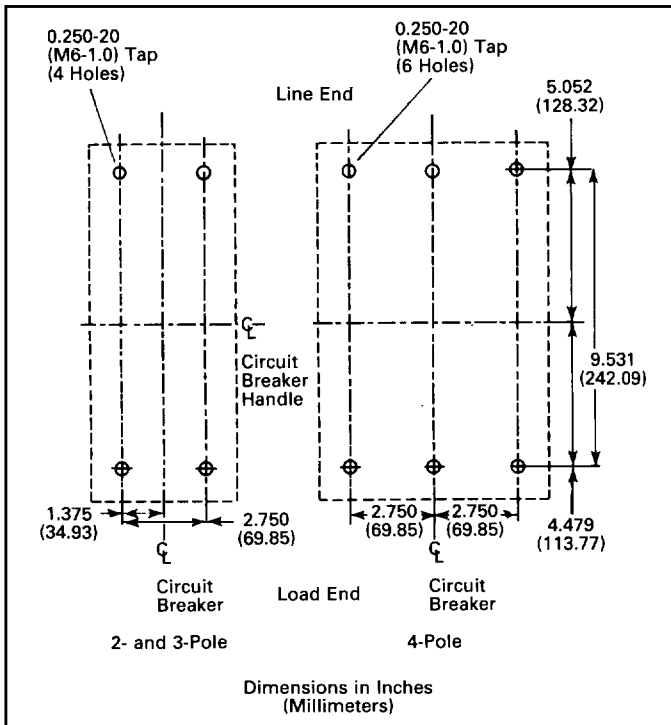

Fig. 2-2 2-, 3-, and 4-Pole Circuit Breaker Mounting Bolt Drilling Plans

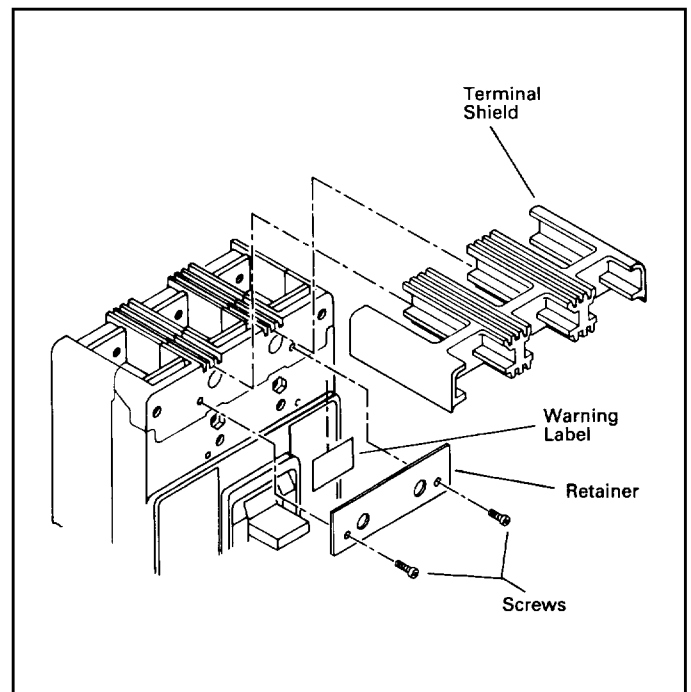

Fig. 2-4 Installation of Terminal Shields and Warning Label



CAUTION

WHEN ALUMINUM CONDUCTORS ARE USED, THE APPLICATION OF A SUITABLE JOINT COMPOUND IS RECOMMENDED TO REDUCE THE POSSIBILITY OF TERMINAL OVERHEATING. OVERHEATING CAN CAUSE NUISANCE TRIPPING AND DAMAGE TO THE CIRCUIT BREAKER.

- 2-7. Connect line and load conductors and accessory leads. 2-8. After the circuit breaker is installed, check all mounting hardware and terminal connecting hardware for correct torque loading. Torque values for line/load terminals are given in Table 2-1 and on the circuit breaker nameplate.
- 2-9. Install line terminal cover on circuit breaker cover with mounting screws provided. Torque to 20-22 lb-in. (2.26-2.49 N.m).
- 2-10. When step-type terminals (Cat. No. TA603LD or TA401LD) are used, terminal shields (supplied with terminals) must be installed on the circuit breaker (Fig. 2-4) and secured using retainer and screws included with the terminal shield kit. Warning label supplied with the kit must be attached to the circuit breaker cover.



WARNING

HAZARDOUS VOLTAGE CONDITIONS CAN CAUSE DEATH OR SEVERE PERSONAL INJURY. MAINTAIN ORIGINAL ELECTRICAL CLEARANCE AND CREEP-AGE SPACINGS AT TERMINATIONS.

3. REPLACEMENT OF EXISTING CIRCUIT BREAKER TYPES LA, HLA, LAB, LC, AND HLC

Although the physical size of L-frame Series C circuit breakers is the same as existing LA, HLA, LAB, LC, and HLC types, there are certain differences including those mentioned below that must be considered when making replacements:

- Panel Escutcheon Cutout Sizes
Existing cutouts must be modified to agree with requirements shown in Fig. 2-3.

- Handle Throw Positions
Existing handle mechanisms may be modified or replaced. Consult Cutler-Hammer for additional information.
- Internal Accessories
Only L-Frame Series C accessories may be used.
- External Accessories
Motor operators must be replaced.
Key interlock mounting brackets must be replaced.
Consult Cutler-Hammer for replacement styles.
- Terminal Wire Connectors
Terminals must be replaced, see Table 2-1 for replacement types.
- Other
Unless noted above, all other physical characteristics are the same.

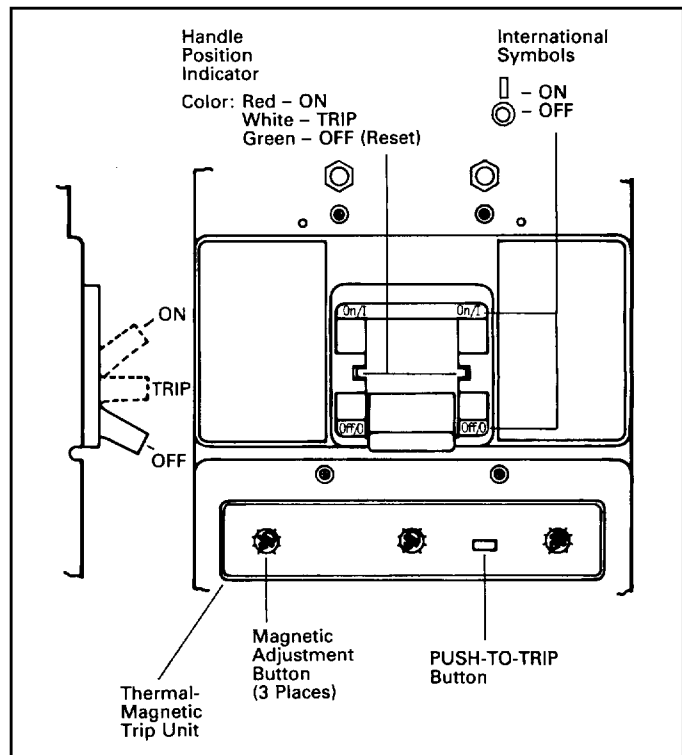

Fig. 4-1 Circuit Breaker Manual Controls

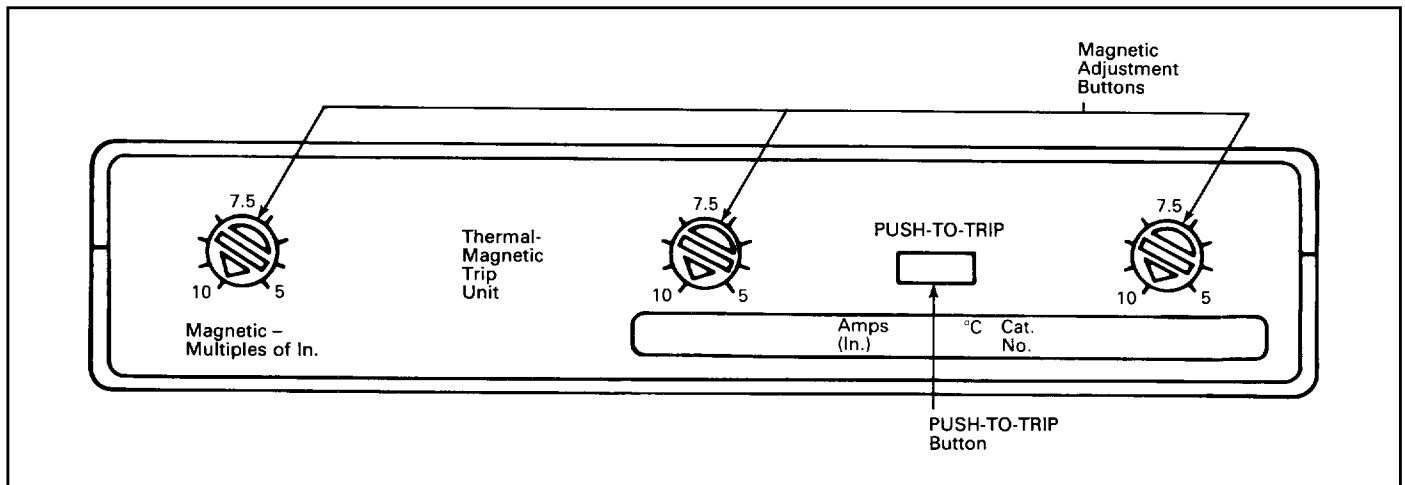

Fig. 4-2 Trip Unit Magnetic Adjustment Buttons



WARNING

CONTACT WITH ENERGIZED EQUIPMENT CAN RESULT IN DEATH, SEVERE PERSONAL INJURY, OR SUBSTANTIAL PROPERTY DAMAGE. DO NOT ATTEMPT TO INSTALL OR PERFORM MAINTENANCE ON EQUIPMENT WHILE IT IS ENERGIZED. ALWAYS VERIFY THAT NO VOLTAGE IS PRESENT BEFORE PROCEEDING WITH THE TASK, AND ALWAYS FOLLOW GENERALLY ACCEPTED SAFETY PROCEDURES.

Note: When replacing an existing circuit breaker of the types listed above, make sure the voltage, continuous current, and interrupting rating of the new circuit breaker are suitable.

4. MANUAL OPERATION, AND THERMAL-MAGNETIC TRIP UNIT ADJUSTMENT

Manual Operation

Manual operation of the circuit breaker is controlled by the circuit breaker handle and the PUSH-TO-TRIP button in the trip unit. The circuit breaker handle has three positions, two of which are shown on the cover with raised lettering to indicate ON and OFF. On the handle, ON, OFF, and trip are also shown by a color-coded strip for each circuit breaker handle position: red for ON, white for tripped, and green for OFF (see Fig. 4-1).

Circuit Breaker Reset

After a trip operation, the circuit breaker is reset by moving the circuit breaker handle to the Reset (extreme OFF) position.

Note: In the event of a thermal (overload) trip the circuit breaker cannot be reset immediately. In a breaker with a thermal-magnetic type trip unit the thermal element needs to cool (up to approximately five minutes) before it can be reset. A circuit breaker with a DIGITRIP RMS trip unit simulates the thermal element with an electronic "thermal memory" that also requires up to five minutes to "cool" before it can be re-energized.

No circuit breaker should be reclosed until the cause of trip is known and the situation rectified.

PUSH-TO-TRIP Button

The PUSH-TO-TRIP button operates the circuit breaker tripping function and may be used to periodically exercise the operating mechanism. In thermal-magnetic trip units, the button is designed to be operated by a small screwdriver. The rating plug in DIGITRIP RMS trip units contains the PUSH-TO-TRIP button which is operated by finger pressure. There is no PUSH-TO-TRIP button in the molded case switch.

Thermal-Magnetic Trip Unit Adjustment

The magnetic element of each pole of the trip unit can be adjusted by rotating the adjustment buttons on the front face of the trip unit with a screwdriver. The buttons have several settings as indicated on the nameplate with val-

ues in multiples of the trip unit ampere rating (I_n) as shown in Fig. 4-2. To adjust the setting, rotate each button clockwise until arrow on button points to desired setting. The molded case switch is set at the factory (at 10X) and is not field adjustable.

Interchangeable Trip Units

For additional information on thermal-magnetic trip units, refer to I.L. 29C607 (3-pole) and I.L. 29C609 (4-pole). For electronic DIGITRIP RMS trip units, refer to I.L. 29C615.

5. INSPECTION AND FIELD TESTING

Series C molded case circuit breakers are designed to provide years of almost maintenance-free operation. The following procedure describes how to do a limited amount of field inspection and testing of a circuit breaker.

Inspection

Circuit breakers in service should be inspected periodically. The inspection should include the following checks 5-1 through 5-8.



WARNING

THE VOLTAGES IN ENERGIZED EQUIPMENT CAN CAUSE SEVERE PERSONAL INJURY OR DEATH. BEFORE INSPECTING THE CIRCUIT BREAKER IN AN ELECTRICAL SYSTEM, MAKE SURE THE CIRCUIT BREAKER IS SWITCHED TO THE OFF POSITION AND THAT THERE IS NO VOLTAGE PRESENT WHERE WORK IS TO BE PERFORMED. SPECIAL ATTENTION SHOULD BE PAID TO REVERSE FEED APPLICATIONS TO ENSURE NO VOLTAGE IS PRESENT.



CAUTION

SOME COMMERCIAL CLEANING AGENTS WILL DAMAGE THE NAMEPLATES OR MOLDED PARTS. MAKE SURE THAT CLEANING AGENTS OR SOLVENTS USED TO CLEAN THE CIRCUIT BREAKER ARE SUITABLE FOR THE JOB.

5-1. Remove dust, dirt, soot, grease, or moisture from the surface of the circuit breaker using a lint-free dry cloth, brush, or vacuum cleaner. Do not blow debris into circuit breaker. If contamination is found, look for the source and eliminate the problem.

5-2. Switch circuit breaker to ON and OFF several times to be sure that the mechanical linkages operate freely and do not bind. If mechanical linkages do not operate freely, replace circuit breaker.

Note: On molded case switches, there is no PUSH-TO-TRIP feature. Omit step 5-3 when installing a molded case switch and proceed with step 5-4.

5-3. With the circuit breaker in the ON position, press the PUSH-TO-TRIP button to mechanically trip the circuit breaker. Trip, reset, and switch circuit breaker ON several times. If mechanism does not reset each time the circuit breaker is tripped, replace the circuit breaker.

5-4. Check base, cover, operating handle, and handle barrier for cracks, chipping, and discoloration. Circuit breakers should be replaced if cracks or severe discoloration is found.

5-5. Check wire connecting terminals and other type bus bar connectors for looseness or signs of overheating. Overheating will show as discoloration, melting, or blistering of conductor insulation, or as pitting or melting of conductor surfaces due to arcing. If there is no evidence of overheating or looseness, do not disturb or tighten the connections. If there is evidence of overheating, terminations should be cleaned or replaced. Before re-energizing the circuit breaker, all terminations and cable should be refurbished to the originally installed condition.

5-6. Check circuit breaker mounting hardware, and tighten if necessary.

5-7. Exposure to certain types of chemicals can cause deterioration of electrical connections. Check area where circuit breaker is installed for any safety hazards, including personal safety and fire hazards and take required precautionary actions.

5-8. The operation of circuit breakers with DIGITRIP RMS trip units can be field tested periodically using the Electronic test kit. (See Selection Data 29-120L.)

Field Testing

Any field testing should be done in accordance with applicable NEMA Standard.

TABLE I: AVAILABLE TRIP UNIT RATINGS

Circuit Breaker Types	Trip Unit Types						
	Thermal-Magnetic ^① Amperes I _n			Electronic (DIGITRIP RMS) ^② Amperes I _n			
	Fixed Thermal	Adjustable Thermal ^③	Adjustable Magnetic (Instantaneous) Multiples of I _n ^③	Trip Unit Rating	Fixed Rating Plug	Adjustable Rating Plug	Adjustable Short Time Multiples of I _n ^③
LDB, LD, HLD, LDC	300 350 400 450 500 600		5 to 10	600	300 350 400 500 600	300/400/500/600	2 to 8
LW, HLW, LWC ^④	315 400 500 630	250 to 315 315 to 400 400 to 500 500 to 630		630	315 350 400 500 600 630	315/400/500/630	

① Not available with type HLDB and LDCB

② Two trip unit types are available:

LES3600LS(G) have fixed, sloping I²t short-time current configuration, (see SC-4544-89).

LES3600LSI(G) have separate adjustable short-time pick-up and short delay settings.

③ For adjustable thermal trip units, the magnetic setting is a multiple of the maximum thermal setting.
For DIGITRIP RMS trip units, the instantaneous/short-time setting is a multiple of the rating plug.

④ Not UL listed

TABLE II: TERMINAL TYPES ①②③⑥

Terminal Cat. No.④	Terminal Material Body	Screw Head Type	AWG Wire Range	Metric Wire Range (MM ²)	Wire Type	Torque Value lb-in (N.m)
TA602LD TA602LDM	Aluminum	Socket	3/0-350 (2)	95-150	Cu/Al	275 (31.1)
TA603LD⑤ TA603LDM⑤	Aluminum	Socket	400-500 (2)	185-240	Cu/Al	275 (31.1)
T602LD T602LDM	Copper	Socket	250-350 (2)	120-150	Cu	275 (31.1)
TA401LD⑤ TA401LDM⑤	Aluminum	Socket	4/0-600	120-300	Cu/Al	400 (45.2)
TA450LD TA450LDM	Aluminum	Socket	4-4/0 (2)	25-120	Cu/Al	275 (31.1)

- ① The maximum width non-standard wire connector (tang-type) or bus bar connector that can be used without reducing electrical clearance and creepage distances between phases is 1.690 inches.
- ② No hardware or connector should be installed in a manner to reduce the electrical clearance between the underneath side of the phase termination (line or load) and ground without the addition of supplementary insulation.
- ③ The metric conductor sizes indicated are the minimum/maximum sizes that can be inserted in the terminal. Larger size conductors may be required to satisfy ampacity requirements for local installation rules.
- ④ "M" suffix in Catalog Number refers to metric terminals for LW, HLW, or LWC breakers.
- ⑤ Sold in 2-, 3-, and 4-pole kits only.
- ⑥ All terminals can accommodate two cables, except TA401LD.

Cutler-Hammer

Pittsburgh, Pennsylvania U.S.A.

Effective June 1998 Style No. 6633C01H07
Printed in U.S.A./CCI

