



Instructions for ND, CND, HND, CHND, NDC and CNDC Circuit Breakers and N-frame Series C Molded Case Switches



WARNING

DO NOT ATTEMPT TO INSTALL OR PERFORM MAINTENANCE ON EQUIPMENT WHILE ENERGIZED. DEATH, SEVERE PERSONAL INJURY, OR SUBSTANTIAL PROPERTY DAMAGE CAN RESULT FROM CONTACT WITH ENERGIZED EQUIPMENT. ALWAYS VERIFY THAT NO VOLTAGE IS PRESENT BEFORE PROCEEDING WITH THE TASK, AND ALWAYS FOLLOW GENERALLY ACCEPTED SAFETY PROCEDURES.

CUTLER-HAMMER IS NOT LIABLE FOR THE MISAPPLICATION OR MISINSTALLATION OF ITS PRODUCTS. THIS PRODUCT IS A DIRECT REPLACEMENT FOR WESTINGHOUSE CIRCUIT BREAKERS.

The user is cautioned to observe all recommendations, warnings, and cautions relating to the safety of personnel and equipment as well as all general and local health and safety laws, codes, and procedures.

The recommendations and information contained herein are based on Cutler-Hammer experience and judgement, but should not be considered to be all-inclusive or covering every application or circumstance which may arise. If any questions arise, contact Cutler-Hammer for further information or instruction.

1. INTRODUCTION

The N-frame Series C circuit breaker (Fig. 1-1) types ND, HND and NDC are 600 VAC maximum rated devices, with integral trip units and interchangeable Rating Plugs. Two continuous current ratings are available 400-800 Amp and 600-1200 Amp. Refer to table 1-1 for available trip units and table 1-2 for available rating plugs. Model D circuit breakers are listed in accordance with Underwriters Laboratories, Inc. Standard UL-489 and satisfy the requirements of the International Electrotechnical Commission Recommendations No. IEC 947-2. Molded case switches are listed in accordance with UL 1087.

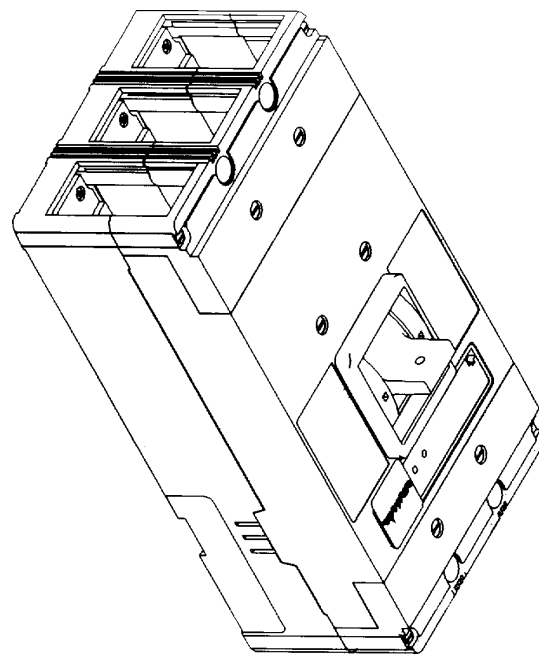

Fig. 1-1 N-frame Series C Circuit Breaker

The Digitrip RMS 310 Trip Units are AC only devices that employ microprocessor based technology that provides true RMS current sensing means for proper correlation with thermal characteristics of conductors and equipment. The primary function of the Trip Unit is circuit protection. This is achieved by analyzing the secondary current signals received from the circuit breaker current sensors and initiating trip signals to the circuit breaker shunt trip when pre-set current levels and time delay settings are exceeded. Low level ground fault protection with an adjustable time delay is supplied when appropriate trip types are selected.

In open air at 40°C, an N-frame circuit breaker with a Digitrip 310 trip unit will carry continuously up to 1200 amperes without exceeding a 50°C rise at the terminals. The calibration of the trip unit is insensitive to ambient temperatures over a range of -20° to +55°C. However, the trip unit contains thermal temperature protective circuitry that initiates a trip operation for self-protection if the internal ambient temperature at the printed circuit board (PCB) reaches approximately 90°C. For ambient conditions above 40°C, derating of the circuit breaker should be considered to avoid exceeding a safe terminal temper-

ature operating range. Consult Cutler-Hammer for recommendations.

Molded Case Switches: The Molded Case Switch is similar to the Circuit Breaker except that it does not have a replaceable rating plug and has a different tripping characteristic. There is a fixed instantaneous trip at 15,000 Ampere but there is no overload short delay or ground fault trip. As a result sections 2.6, 2.7, 4, 5, 6.8 and 7 are not applicable. In the remaining sections the term circuit breaker shall also include the molded case switch.

100 Percent Rated N-Frame Circuit Breaker: CND, CHND and CNDC circuit breakers are suitable for continuous operation at 100 percent of the frame rating in an enclosure which measures at least 42" height, 22 3/4" width and 11 1/2" depth. The 800A version requires no ventilation. The 1200A version requires 224 inch² ventilation on the front face of the enclosure (72 sq. in. top, 72 sq. in. bottom, 40 sq. in. left and 40 sq. in. right). Furthermore the 1200A version has to be used with the supplied conductor extensions and terminal barriers as shown in

Figure 2-2. Use only 90°C rated wire with ampacity based on 75°C rated conductors. Use Copper only or AL9CU terminals only.

Overload Trip: In accordance with standards requirements, the trip unit initiates a trip of the circuit breaker within two hours for an overload of 135 percent, and a trip in less time for higher overloads.

A "Thermal Memory" effect prevents the breaker from being re-energized immediately after an overload. A "cooling off" period of up to 5 minutes is required, which allows time for cabling to cool off.

Short delay/Instantaneous Trip: For short circuit conditions that exceed the short delay pick-up settings, the trip units initiates a trip after a delay prescribed by the I²t ramp function for trip units designated T33 and T35. A flat response time delay action is provided by trip units designated T32 and T36 unless the instantaneous (I) setting is selected.

TABLE 1-1: ELECTRONIC (DIGITRIP 310) TRIP UNIT TYPES

Trip Unit Functions		Digitrip RMS 310 Trip Unit				
		T33	T32	T35	T36	K
Long Time	Fixed Ampere Rating ① with Fixed Long Delay	●	●	●	●	
	Adjustable Ampere Setting with Fixed Long Delay②	●	●	●	●	
Short Time	Adjustable Short Time Pick-up with Short Time Delay I ² t Ramp	●		●		
	Adjustable Short Time Delay③ with Adjustable Short Time Pick-up, or		●		●	
	Adjustable Instantaneous Pick-up③		●		●	
Instantaneous	Fixed Instantaneous (Override)④	●	●	●	●	●
Ground Fault	Adjustable Ground Fault Pick-up with Adjustable Ground Fault Time			●	●	

① Fixed rating plugs available, see table 1-2.

② Optional four-setting adjustable rating plugs available, see table 1-2.

③ Using trip unit with adjustable delay (T32, T36), instantaneous pick-up is achieved when the lowest time delay setting (I) is selected.

④ Override setting fixed at frame withstand rating.

TABLE 1-2: ELECTRONIC (DIGITRIP 310) TRIP UNIT FUNCTION AND RATING SENSING

Trip Function	Rating/Setting Description ③	
Ampere Rating Fixed at 100%	Fixed rating plugs available	
	Trip Unit Ampere Rating	Fixed Rating Plugs
	1200 Amp 800 Amp	600, 630①, 700, 800, 1000, 1200, 1250①A (I _n) 400, 450, 500, 550, 600, 630①, 700, 800A (I _n)
Adjustable Long Time Pick-up	Adjustable rating plugs available	
	Trip Unit Ampere Rating	Adjustable Rating Plugs
	1200 Amp 800 Amp	600,800,1000,1200A (I _n) 400,500,600,800A (I _n)
Short Delay Pick-up (Adjustable)	In multiples of installed rating plug amperes (I _n) with marks at 2-3-4-5-6-7-8x	
Short Delay Time (Fixed)	I ² t ramp configuration	
Short Delay Time (Adjustable)	Flat response with time delay settings at 100 ms, 200 ms, and 300 ms	
Instantaneous Pick-up ②	In multiples of installed rating plug amperes (I _n) with marks at 2-3-4-5-6-7-8x	
Ground Fault Pick-up (adjustable)	Trip Unit Ampere Rating	Trip Unit Setting
	1200 Amp 800 Amp	200, 400, 600, 800, 1000 and 1200 Amp 200, 400, 600, 800, 1000 and 1200 Amp
Ground Fault Time Delay	Settings at instantaneous (I) 150 ms, 300 ms, and 500 ms	

① Not UL listed

② Occurs with short delay time adjustment set at I.

③ The Molded Case Switch has a fixed non-interchangeable rating plug

Ground Fault Protection: When selected, ground fault pick-up and time delay settings shown in Table 1-2 allow selective ground fault coordination with other circuit protection devices.

Ground Fault Alarm Unit: A ground fault alarm unit may be used with the trip unit to provide visual indication and a contact closure when a ground fault trip occurs. The ground fault trip alarm unit is ordered and shipped separately if required.

DC Application: Digitrip 310 trip units are suitable for AC application only.

Field Testing: Test points are available for functional field testing of the trip unit when connected to test kit (Catalog No. STK2).

Internal Accessories: Internal accessories mount on the Digitrip trip unit. A list of internal accessories and their instruction leaflets is provided below:

- Alarm (Signal)/Lockout (ASL) Switch I.L. 29C184
- Auxiliary Switch I.L. 29C124
- Shunt Trip I.L. 29C148
- Low Energy Shunt Trip I.L. 29C145
- Undervoltage Release Mechanism (Handle Reset) I.L. 29C174

Note: Shunt trip and undervoltage accessories, if required, must be mounted in the left pole.

Note: Digitrip 310 trip unit versions with ground fault protection are supplied with an auxiliary switch, mounted in the right pole of the trip unit.

This instruction leaflet gives procedures for installation and field testing of N-frame Series C circuit breakers and describes the different trip unit characteristics. For this publication, the term circuit breaker shall also include the molded case switch.

2. INSTALLATION

The installation procedure consists of inspecting the circuit breaker, installing the accessories and terminals if required, mounting the circuit breaker, connecting the line and load conductors and accessory wiring, adjusting the trip settings, and installing the rating plug. Circuit breakers, accessories, terminals, and rating plugs may be supplied in separate packages. To install the circuit breaker, perform the following steps:

2.1 Inspection

Make sure that the circuit breaker is suitable for the intended installation by comparing nameplate data with existing equipment ratings and system requirements. Inspect the circuit breaker for completeness and check for damage before mounting.

2.2 Accessory Installation

Note: If required, internal accessory installation in any type of circuit breaker should be done before the circuit breaker is mounted and connected. Refer to the individual accessory instruction leaflets listed above.

Install accessories per the accessory instruction leaflet.



CAUTION

CIRCUIT BREAKER COVER CONSTRAINS MOVING PARTS. DO NOT OPERATE THE BREAKER WITHOUT THE COVER INSTALLED.

2.3 Terminal Installation

100 Percent Rated N-Frame: Connect the supplied line and load conductor extensions as shown in Fig. 2-2. For a 4 pole breaker do not connect the conductor extensions to the neutral pole.

If not already installed, mount terminals as shown in Fig. 2-1 (100 Percent Rating Fig. 2-2). To do this, the terminal cover screws must first be loosened and the terminal covers removed.

2.4 Mounting the Circuit Breaker



WARNING

VOLTAGE IN ENERGIZED EQUIPMENT CAN CAUSE DEATH OR SEVERE PERSONAL INJURY. BEFORE MOUNTING THE CIRCUIT BREAKER IN AN ELECTRICAL SYSTEM MAKE SURE THERE IS NO VOLTAGE PRESENT WHERE WORK IS PERFORMED. SPECIAL ATTENTION SHOULD BE PAID TO REVERSE FEED APPLICATIONS TO ENSURE NO VOLTAGE IS PRESENT.

To mount the circuit breaker, perform the following steps:

- For individual surface mounting, drill mounting panel using the drilling plan shown in Fig. 2-3. For dead front cover applications, cut out cover to correct escutcheon dimensions, see Fig. 2-4.
- If circuit breaker includes factory or field installed internal accessories, make sure the accessory wiring can be reached when the circuit breaker is mounted.

Note: Labels with accessory connection schematic diagrams are provided on the side of the circuit breaker. A note should be made of the diagrams if the labels cannot be seen when the circuit breaker is mounted.

- Position circuit breaker on mounting surface.
- Secure circuit breaker with customer supplied hardware.

2.5 Connecting Line and Load Conductors

Remove line and load end covers.



CAUTION

OVERHEATING CAN CAUSE NUISANCE TRIPPING AND DAMAGE TO THE CIRCUIT BREAKER. WHEN ALUMINUM CONDUCTORS ARE USED, THE APPLICATION OF A SUITABLE JOINT COMPOUND IS RECOMMENDED TO REDUCE THE POSSIBILITY OF TERMINAL OVERHEATING.

Connect line and load conductors and accessory leads. If the circuit breaker includes ground fault protection, connect the neutral current sensor and ground fault alarm unit as described in section 5 and as shown in Fig 5-2.

For bus connections use:
 .500-13 bolts (English Threads)
 For front mounted bus connections, socket cap screws
 are recommended.

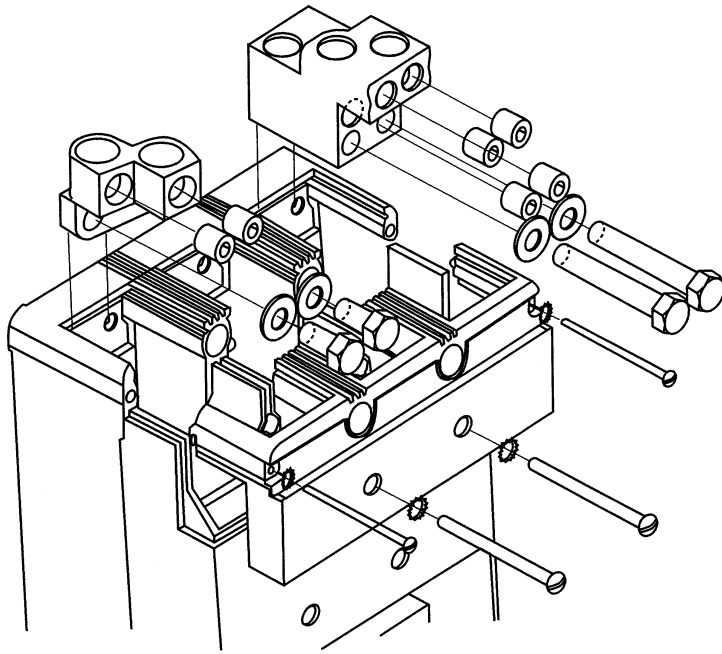

Torque Table (Domestic)

Terminal Cat. No.	Wire Size MCM	Cond. Mat'l	Torq. lb - in
TA700NB1	#1 - 500 (2)	CU / AL	375
TA1000NB1	3/0 - 400 (3)	CU / AL	375
TA1200NB1	4/0 - 500 (4)	CU / AL	375
TA1201NB1	500 - 750 (3)	CU / AL	450
T700NB1	2/0 - 500 (2)	CU ONLY	300
T1000NB1	3/0 - 500 (3)	CU ONLY	300
T1200NB3	3/0 - 400 (4)	CU ONLY	275

Fig. 2-1 Terminal Installation

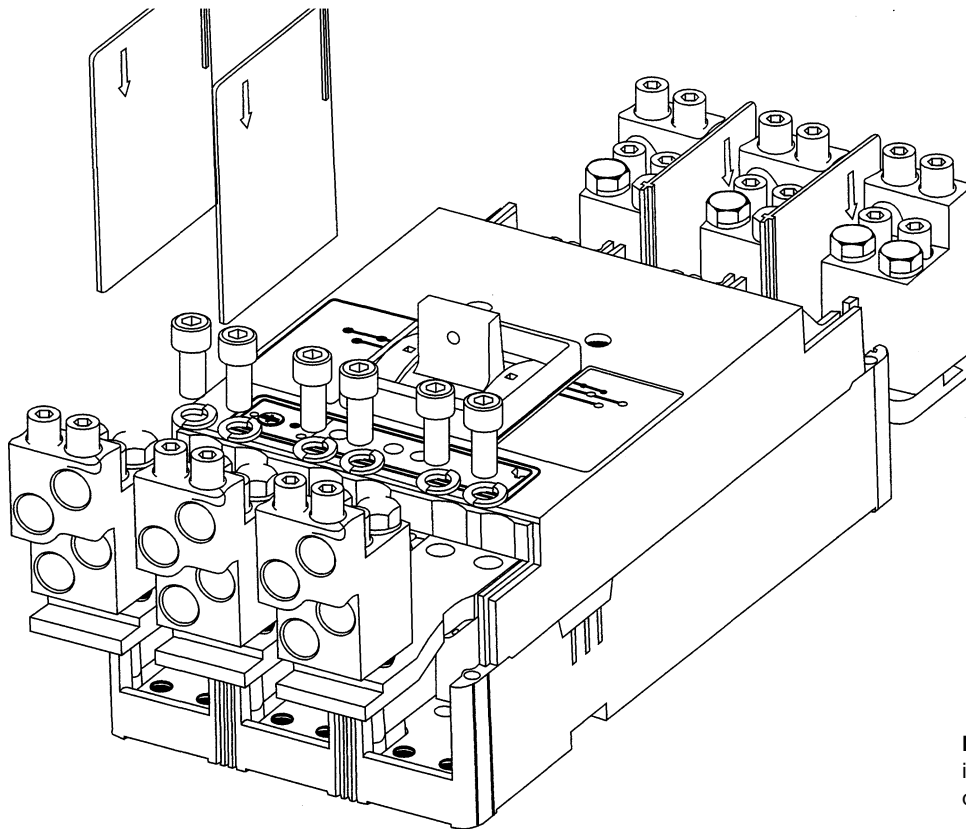

Terminals are not included in the conductor extension kit. Terminals must be purchased separately.

Note: Conductor extensions increase breaker length by 3.75" on each end.

Fig. 2-2 Conductor Extensions and Terminal Installation for 100% Rating

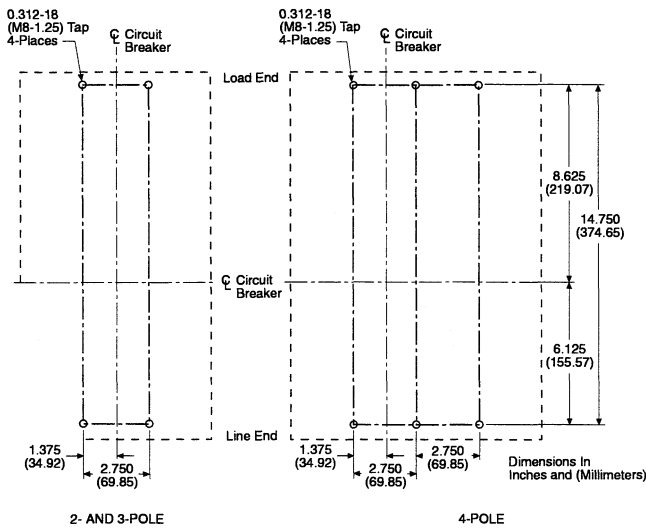

Fig. 2-3 Breaker Mounting Bolt Drilling Plan

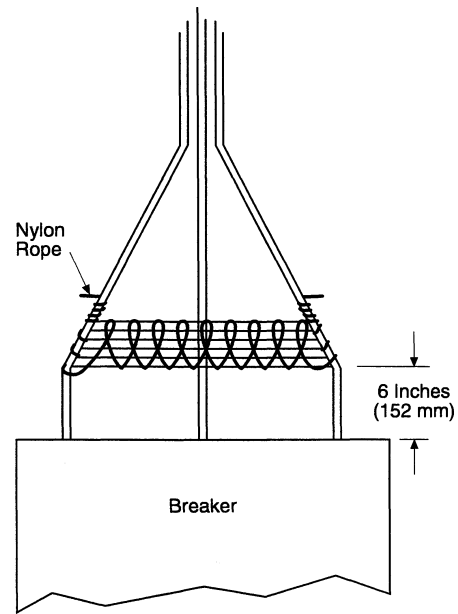

Fig. 2-5 Securement of Cable (See caution note for bracing instruction)

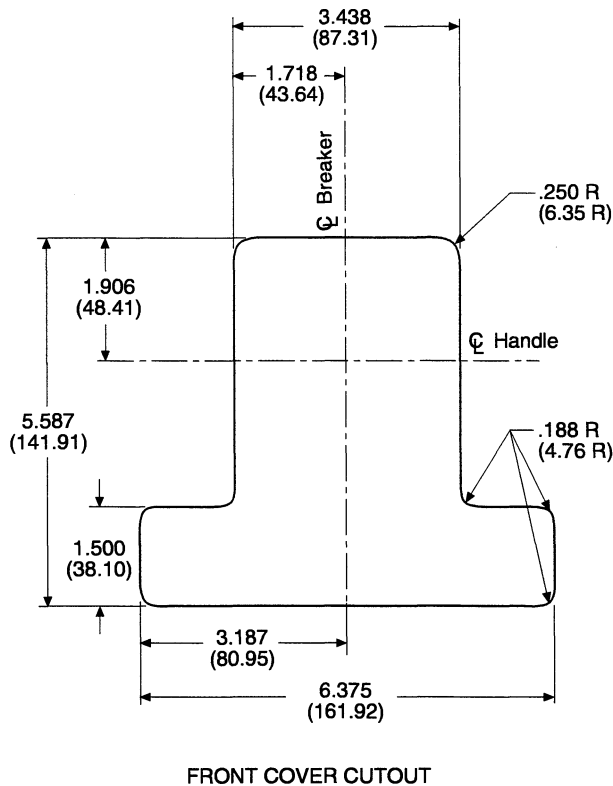

Fig. 2-4 Circuit Breaker Escutcheon Dimension



WARNING

HAZARDOUS VOLTAGE CONDITIONS CAN CAUSE DEATH OR SEVERE PERSONAL INJURY. MAINTAIN ORIGINAL ELECTRICAL CLEARANCE AND CREEP-AGE SPACINGS AT TERMINATIONS.

After the circuit breaker is installed and all connections are made, check all mounting hardware and terminal connection hardware for torque loading. Torque values for line/load terminal lugs are given on the circuit breaker nameplate and table in Fig. 2-1. Torque mounting screws to 30-35 lb-ft. (41-47 Nm).

Re-install load end and line end covers and secure with pan head screws provided. Torque large screws to 35-45 lb-in. (4.0-5.0 Nm) and small screws to 24-30 lb-in (2.7-3.4 Nm). When using the terminals TA700NB1 or T700NB1, or when prospective fault currents of cabled installations exceed 65kA (such as NDC applications) the conductors are to be braced in accordance with Fig. 2-5.



CAUTION

UNSUPPORTED CABLES CAN CAUSE MINOR PERSONAL INJURY OR EQUIPMENT DAMAGE UNDER SHORT CIRCUIT CONDITIONS.

Wrap conductor cables with 3/8" nylon or equivalent rope as shown in Fig. 2-5, having a minimum tensile strength of 2000 lbs, at 6" from terminals and every additional 6" with 5 wraps or every additional 1" with 1 wrap.

Note: Steps 2.6 and 2.7 are not required for the molded case switch.

2.6 Adjusting Trip Settings

The N frame Series C circuit breakers have the trip unit built in as an integral part of the breaker. The trip unit is not field replaceable. The various trip unit settings are described in section 4. They should be adjusted as required at this point.

2.7 Rating Plug Installation

The circuit breaker requires the installation of a rating plug to make it operational. The installed rating plug establishes the maximum continuous current rating (I_n) of the circuit breaker. A typical rating plug is shown in Fig. 2-5. Available rating plugs are listed in Table 1-2.

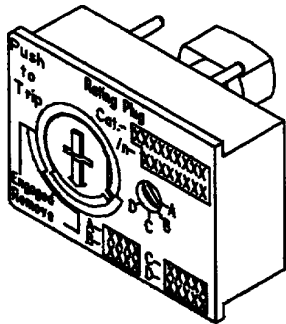

Fig. 2-6 Rating Plug

To install the rating plug perform the following steps:

Note: Before attempting to install the rating plug, the arrow in the Push-to-Trip button portion of the plug must be pointed toward the REMOVE position. This can be done with a small screwdriver.

- Position the rating plug as shown in Fig. 2-7.
- Make sure the arrow on the rating plug Push-to-Trip button is pointing at REMOVE. Adjust, if necessary, using a flat blade screwdriver.
- The projections on the rating plug shaft must line up with the matching slot in the trip unit and the contact pins must match with the sockets in the PC board.
- Push the rating plug in as far as it will go. The electrical contact pins will enter matching holes in the trip unit.

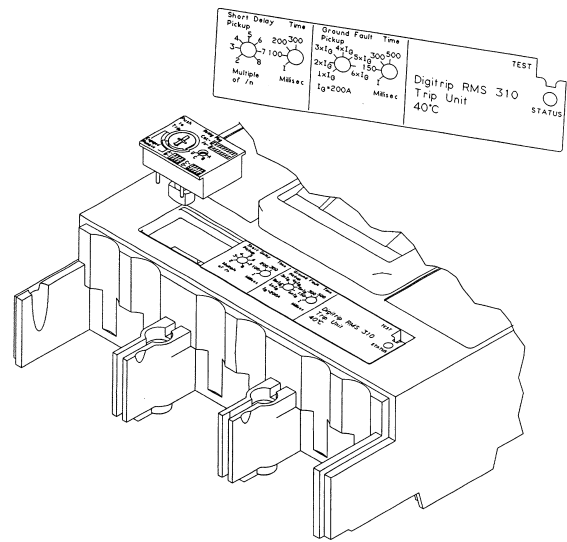

Fig. 2-7 Rating Plug Installation

- Place a flat blade screwdriver in the slot on the Push-to-Trip button. Press approximately 1/16 inch and turn button 90° clockwise.
- If an adjustable rating plug is installed, four continuous current settings are possible. Set the switch marked A,B,C,D to the current rating desired.

The circuit breaker is now ready for operation.

Note: The reverse procedure is used to remove the rating plug. Turn the Push-to-Trip button to the remove position. This action will cause the circuit breaker to trip. Then grasp the lip of the Push-to-Trip button and gently pull. A small screwdriver placed under the left edge of the Push-to-Trip button will assist in removal.

3. OPERATION

3.1 Manual Operation

Manual operation of the circuit breaker is controlled by the circuit breaker handle and the Push-to-Trip button. The circuit breaker handle has three positions, two of which are shown on the cover raised lettering to indicate ON and OFF. On the handle, ON, OFF, and TRIP are also shown by a color-coded strip for each circuit breaker handle position: red for ON, white for TRIP, and green for OFF (See Fig. 3-1.). The Push-to-Trip button checks the circuit breaker tripping function and may be used to periodically exercise the operating mechanism. The button, located in the rating plug, is designed to be operated by finger pressure.

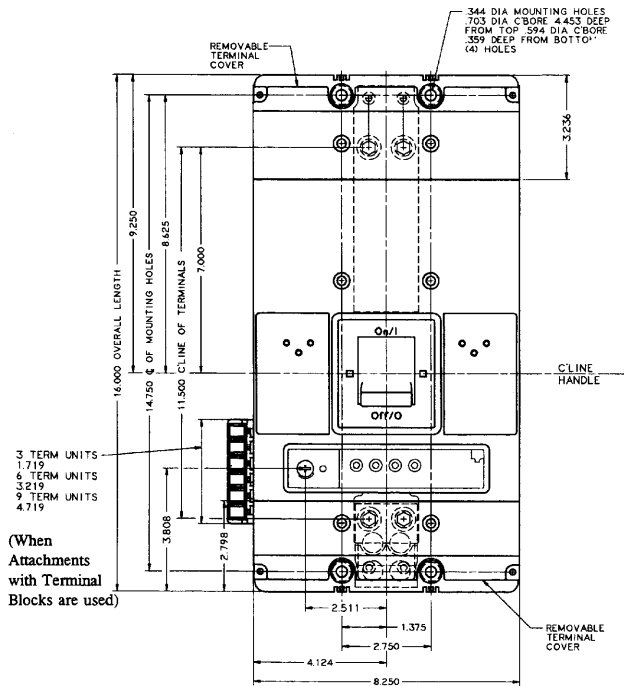

Fig. 3-1 Circuit Breaker Manual Controls

3.2 Circuit Breaker Reset

After an automatic or accessory initiated trip, or a manual push-to-trip operation, the circuit breaker is reset by moving the circuit breaker handle to the extreme OFF position.

4. NES DIGTRIP 310 TRIP UNIT ADJUSTMENTS

4.1 Ampere Rating

The installed rating plug establishes the maximum continuous current rating (I_n) of the circuit breaker. A typical rating plug is shown in Fig. 2-6. Available rating plugs are listed in Table 1-2.

An optional adjustable rating plug provides four ampere setting selections in a single rating plug. Fig. 4-1 shows time/current curve details for adjustable rating plug Cat. No. A12NES1200T1. Time/current curves for other adjustable rating plugs are similar.

A green status light indicates the operational status of the trip unit. If the load current through the circuit breaker exceeds approximately 200 Amps the status light will blink on and off once each second. A blinking status light is an indication of a properly functioning trip unit. If the status light is not blinking, the current through the breaker

may be less than 200 Amps. If the current exceeds 200 Amps and the status light is not blinking, use the STK2 test kit to investigate (see section 6.8).



CAUTION

LACK OF ILLUMINATION OF THE STATUS LIGHT DOES NOT INDICATE THE TERMINALS OF THE BREAKER ARE DEENERGIZED.

4.2 Long Time Pick Up and Delay

Neither the long time pick up or the long time delay are adjustable. The long time pick up (the current at or above which the circuit breaker will trip) occurs between 1.05 and 1.25 times I_n . If the status light is on steady, it indicates a trip is pending. The long delay time normally has the characteristics $t = 360 / (I_n)^2 \pm 20\%$. For example, at $I_n = 6$ per unit, $t = 10$ seconds $\pm 20\%$. There is however, a memory effect that can act to shorten the long delay. The memory effect comes into play if a current above the long delay pick up value exists for a time and then is cleared by the tripping of a down stream device or the circuit breaker itself. A subsequent overload will cause the circuit breaker to trip in shorter time than normal. The amount of time delay reduction is inverse to the amount of time that has elapsed since the previous overload. Approximately five minutes is required between overloads to completely reset the memory.

4.3 Time and Pick-up Adjustments

One to four adjustment settings are available depending on the particular breaker purchased. An eight -position rotary switch is provided for each. The rotary switches are adjusted using a small flat blade screwdriver. If the switch is turned to a setting not marked on the trip unit nameplate, the trip unit defaults to the minimum setting.

The available settings along with the effect of changing each setting are illustrated in Figs. 4-2 to 4-4.

4.4 Short Delay Pick-up Setting

Seven settings are available that range from 2 to 8 times (I_n) as shown in Figs. 4-2 and 4-3.

4.5. Short Delay Time Setting

Four settings (1,100,200,300 milliseconds) are available on trip units designated T32 and T36 (see Fig. 4-3). The I setting gives a trip response with no intentional delay (Instantaneous).

4.6 Ground Fault Pick-up Setting

Six settings marked 1x through 6x I_G (where $I_G = 200$ Amps) are available (see Fig. 4-4).

Note: These ampere values are always the same no matter what rating plug is installed in the circuit breaker.

4.7 Ground Fault Time Settings

Four flat settings (1,150,300,500 milliseconds) are available (see Fig. 4-4). The 1 setting gives a trip response with no intentional delay (instantaneous).

5. GROUND FAULT CIRCUIT BREAKERS



WARNING

BREAKER TRIP UNIT CAN BE DAMAGED BY HI-POTTING OR APPLYING EXTERNAL POWER TO ANY COMBINATION OF THE YELLOW, GREEN, GRAY OR WHITE LEADS. DAMAGE TO THE TRIP UNIT MAY LEAD TO DEATH, SERIOUS PERSONAL INJURY, OR PROPERTY DAMAGE. MAKE CONNECTIONS TO THESE LEADS ONLY AS DIRECTED BY THIS INSTRUCTION LEAFLET.

Ground Fault circuit breakers are supplied from the factory with one auxiliary switch with pigtail leads (red, blue and black wires) and pigtail lead connections for a neutral current sensor (white and grey wires) and a ground fault alarm relay (yellow and green) wires, all installed in the right pole of the trip unit. A neutral current sensor is provided with each trip unit. The ground fault alarm relay is ordered and shipped separately if required (Cat. # GFAU).

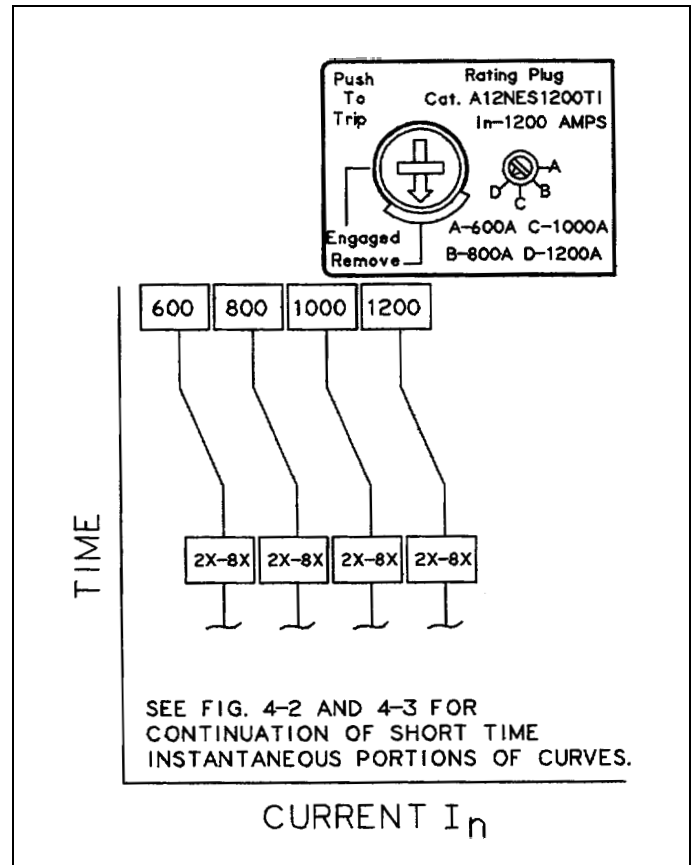

Fig. 4-1 Optional Adjustable Rating Plug

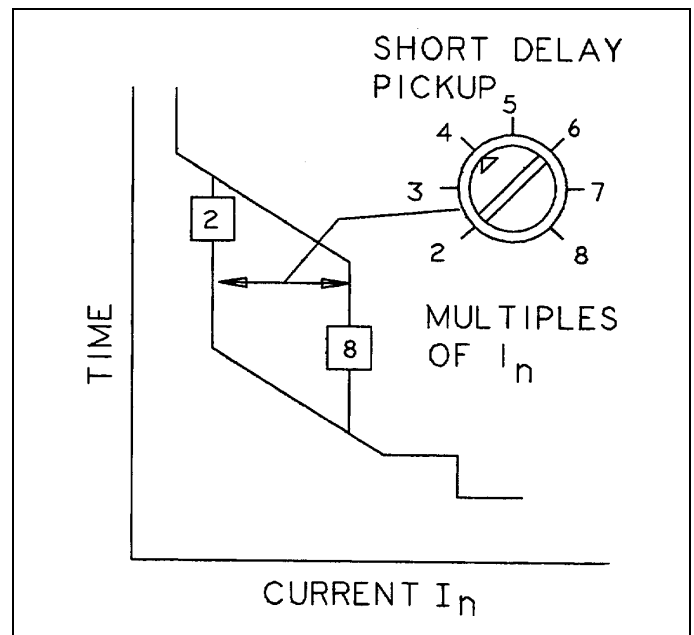

Fig. 4-2 Short Trip Current Adjustment and Curve Details for T33 and T35 Type Trip units

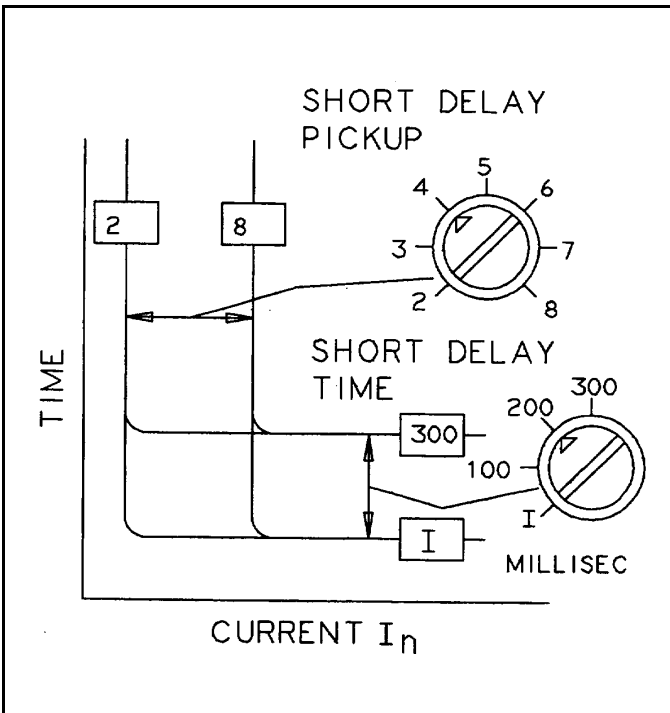

Fig. 4-3 Short Delay Trip Current and Short Delay Trip Time Adjustment and Curve Details for T32 and T36 Type Trip Units

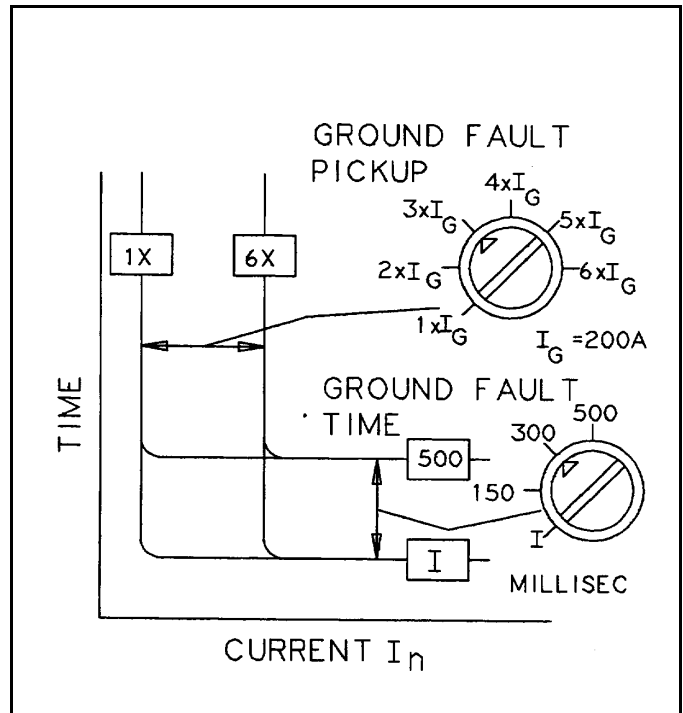

Fig. 4-4 Ground Fault Trip Unit Current, and Ground Fault Trip Time Adjustment and Curve Details

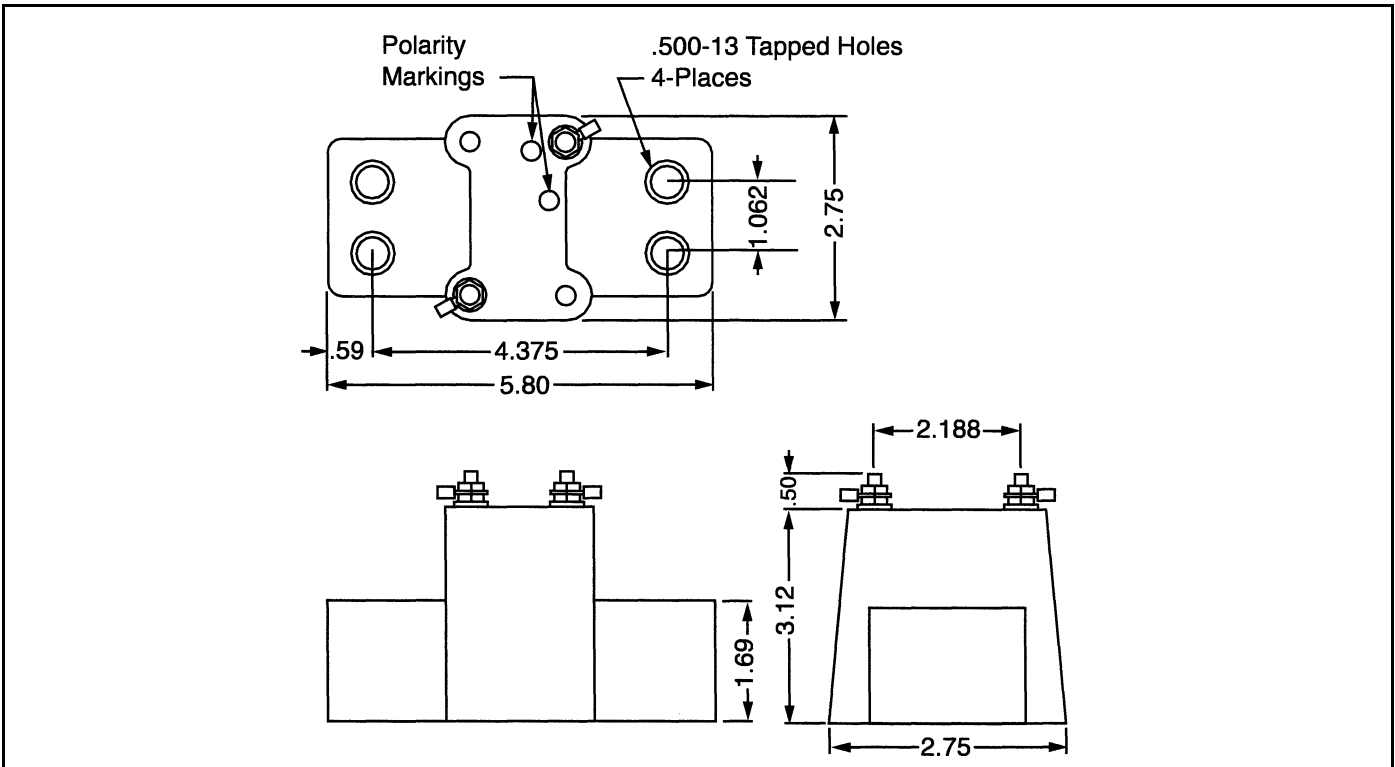

Fig. 5-1 Neutral Sensor Outline

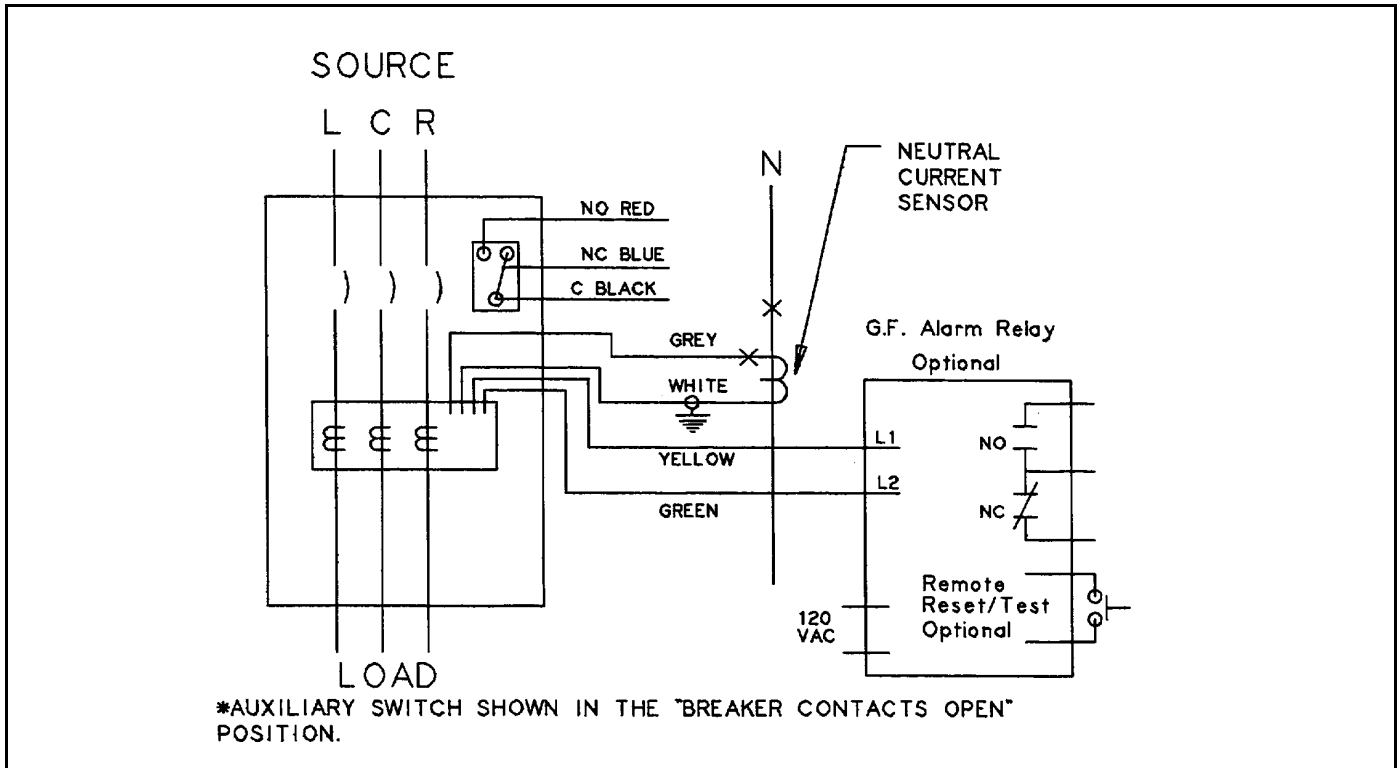

Fig. 5-2 Connection Diagrams Ground Fault Breaker - Figure indicates normal feed installation. Neutral sensor is wired identically for reverse feed applications.

Ground fault circuit breakers detect ground fault currents through residual sensing (they are not designed to use source ground or zero sequence ground fault sensing methods). If the system neutral is grounded, but no phase to neutral loads are used, the neutral current sensor is not necessary.

If the system neutral is grounded and phase or neutral loads are used, then the neutral current sensor (see Fig. 5-1) must be used. It should be connected to the breaker according to Fig. 5-2.

The neutral sensor has the same ratio as the breaker current sensors.

Note: The polarity of the sensor connections is critical. Always observe the polarity markings on the installation drawings. To insure correct ground fault equipment performance, conduct field test to comply with National Electric Code requirements under article 230-95(C). See section 7 for testing instructions.

6. INSPECTION AND FIELD TESTING

Series C molded case circuit breakers are designed to provide years of almost maintenance-free operation. The

following procedure describes how to inspect and test a circuit breaker in service.

Inspection

Circuit Breakers should be inspected periodically. This inspection can be best done during normal equipment maintenance periods when no voltage to the equipment is available. The inspection should include the following checks 6-1 through 6-8.



WARNING

VOLTAGES IN ENERGIZED EQUIPMENT CAN CAUSE SEVERE PERSONAL INJURY OR DEATH. BEFORE INSPECTING THE CIRCUIT BREAKER IN AN ELECTRICAL SYSTEM, MAKE SURE THE CIRCUIT BREAKER IS SWITCHED TO THE OFF POSITION AND THAT THERE IS NO VOLTAGE PRESENT WHERE WORK IS TO BE PERFORMED. SPECIAL ATTENTION SHOULD BE PAID TO REVERSE FEED APPLICATIONS TO ENSURE NO VOLTAGE IS PRESENT.



CAUTION

SOME COMMERCIAL CLEANING AGENTS WILL DAMAGE THE NAMEPLATES OR MOLDED PARTS. MAKE SURE THAT CLEANING AGENTS OR SOLVENTS USED TO CLEAN THE CIRCUIT BREAKER ARE SUITABLE FOR THE JOB.

- 6.1 Remove dust, dirt, soil, grease, or moisture from the surface of the circuit breaker using a lint-free dry cloth, brush, or vacuum cleaner. Do not blow debris into the circuit breaker. If contamination is found, look for the source and eliminate the problem.
- 6.2 Switch circuit breaker to ON and OFF several times to be sure that the mechanical linkages are free and do not bind. If mechanical linkages are not free, replace circuit breaker.
- 6.3 With the circuit breaker in the ON position, press the PUSH-TO-TRIP button to mechanically trip the circuit breaker. Trip, reset, and switch circuit breaker ON several times. If mechanism does not reset each time the circuit breaker is tripped, replace the circuit breaker.
- 6.4 Check base, cover, and operating handle for cracks, chipping, and discoloration. Circuit breakers should be replaced if cracks or severe discoloration is found.
- 6.5 Check terminals and connectors for looseness or signs of overheating. Overheating will show as discoloration, melting, or blistering of conductor insulation, or as pitting or melting of conductor surface due to arcing. If there is no evidence of overheating or looseness, do not disturb or tighten the connections. If there is evidence of overheating, terminations should be cleaned or replaced. Before re-energizing the circuit breaker, all terminations and cable should be refurbished to the same condition as when originally installed.
- 6.6 Check circuit breaker mounting hardware, and tighten if necessary.
- 6.7 Check area where circuit breaker is installed for any safety hazards, including personal safety and fire hazards. Exposure to certain types of chemicals can cause deterioration of electrical connections.
- 6.8 The operation of circuit breakers with Seltronic trip units can be field tested using the Seltronic test kit, Cat. No. STK2. (See frame Book 29-106).

7. PERFORMANCE TESTING FOR GROUND FAULT CIRCUIT BREAKERS

7.1 Code Requirements

The National Electric Code under Article 230-95-C requires that any ground-fault protection system be performance tested when first installed. The test shall be conducted in accordance with approved instructions provided with the equipment. A written record of this test shall be made and shall be available to the authority having inspection jurisdiction.

7.2 Standards Requirements

As a follow-up to the basic performance requirements stipulated by the N.E.C. as stated above in 7-1, UL Standard No. 1053 requires that certain minimum instructions must accompany each ground fault protection system. These following statements plus a copy of the test record form illustrated in Fig. 7-2 are shipped with each N-frame ground fault circuit breaker.

7.3 General Test Instructions

- 7.3.1 The interconnected system shall be evaluated in accordance with the equipment assembler's detail instruction by qualified personnel.
- 7.3.2 The polarity of the neutral sensor connection (if used) must agree with equipment assembler's detailed instructions to avoid improper operations following apparently correct simulated test operations. Where a question exists, consult the specifying engineer and/or equipment assembler.
- 7.3.3 The grounding points of the system shall be verified to determine that ground paths do not exist that would bypass the sensors. High-voltage testers and resistance bridges may be used.



WARNING

THERE IS A HAZARD OF ELECTRICAL SHOCK OR BURN WHENEVER WORKING IN OR AROUND ELECTRICAL EQUIPMENT. ALWAYS TURN OFF POWER SUPPLYING BREAKER BEFORE CONDUCTING TESTS.

Note: Since the ground fault circuit breakers derive their operating power from the phase current, and not from the neutral current, passing current through the neutral sensor only will not properly test the ground fault feature.

- 7.3.4 Using a low voltage (0-24V), high current, AC source, apply a test current of 125% of the ground fault pick-up setting through one phase of the circuit breaker, as shown in Fig. 7-1a. This should cause the breaker to trip in less than 1 second, and if an alarm indicator is supplied, it should operate. Reset the breaker and the alarm indicator. Repeat the test on the other two phases.
- 7.3.5 If the system is a 4-wire system with a neutral current sensor, apply the same current as described in paragraph 7.3.4 above through one phase of the breaker, returning through the neutral sensor, as shown in Fig. 7-1b. The breaker should not trip, and the alarm indicator, if supplied, should not operate. Repeat the test on the other two phases.
- 7.3.6 If the system is a 3-wire system with no neutral current sensor, apply the same current as described in paragraph 7.3.4 above through any two phases of the breaker, with the connections

exactly shown in Fig. 7-1c. The breaker should not trip, and the alarm indicator, if supplied, should not operate.

Repeat the test using the other two combinations of breaker phases.



CAUTION

FIELD TESTING SHOULD BE USED FOR FUNCTIONAL TESTING AND NOT FIELD CALIBRATION.

ANY TEMPORARY CONNECTION MADE FOR THE PURPOSE OF CONDUCTING TESTS SHOULD BE RESTORED TO PROPER OPERATING CONDITIONS BEFORE RETURNING THE BREAKER TO SERVICE.

7.3.7 The results of the test are to be recorded on the test form provided with the equipment.

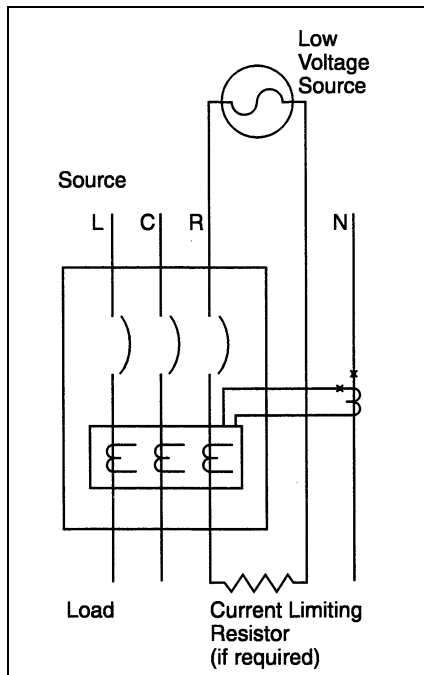

Fig. 7-1a Connections for Ground Fault Test

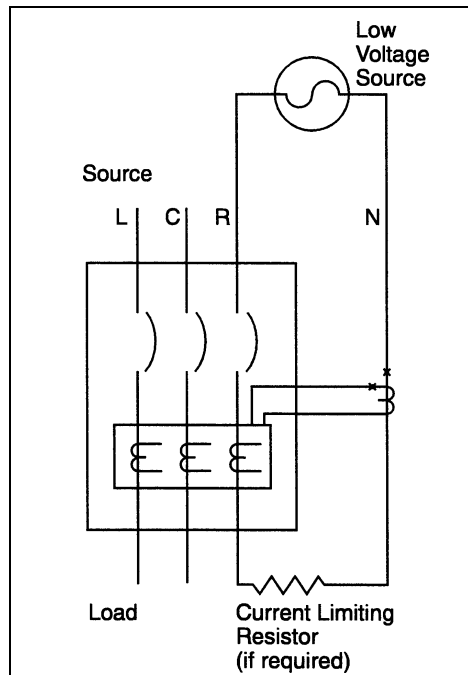

Fig. 7-1b Connection for Ground Fault No-Trip Test, with a Four Wire System

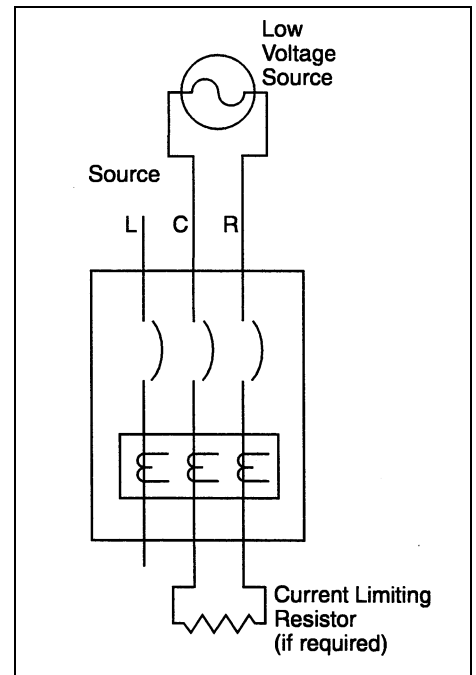

Fig. 7-1c Connections for Ground Fault No-Trip Test, with a Three Wire System

GROUND FAULT TEST RECORD FORM

Ground Fault Test Record should be Retained by Those in Charge of the Building's Electrical Installation in order to be available to the Authority having Jurisdiction.

Test Date	Circuit Breaker Number	Results	Tested By:

Fig. 7-2 Typical Performance Test Record

NOTES

Cutler-Hammer

Pittsburgh, Pennsylvania U.S.A.

Effective September 1999 Style No. 6634C95H02
Printed in U.S.A./CCI

