

Installation Instructions for KD, HKD, KDC, CKD, CHKD, Circuit Breakers with Digitrip OPTIM Trip Unit and Powernet and/or Zone Interlock

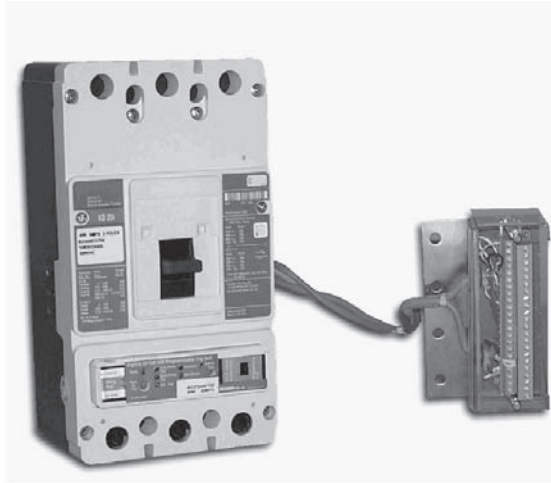

Contents

Description	Page
1. Introduction	2
2. Installation	2
3. Manual Operation	7
4. Inspection and Field Testing	7



Powering Business Worldwide



WARNING

CONTACT WITH ENERGIZED EQUIPMENT CAN RESULT IN DEATH, SEVERE PERSONAL INJURY, OR SUBSTANTIAL PROPERTY DAMAGE. DO NOT ATTEMPT TO INSTALL OR PERFORM MAINTENANCE ON EQUIPMENT WHILE IT IS ENERGIZED. ALWAYS VERIFY THAT NO VOLTAGE IS PRESENT BEFORE PROCEEDING WITH THE TASK, AND ALWAYS FOLLOW GENERALLY ACCEPTED SAFETY PROCEDURES.

EATON IS NOT LIABLE FOR THE MISAPPLICATION OR MISINSTALLATION OF ITS PRODUCTS.

The user is cautioned to observe all recommendations, warnings and cautions relating to the safety of personnel and equipment as well as all general and local health and safety laws, codes and procedures.



Figure 1-1 K-Frame OPTIM Series C Circuit Breaker Frame (OPTIM 550 Shown)

The recommendations and information contained herein are based on Eaton experience and judgement, but should not be considered to be all-inclusive or covering every application or circumstance which may arise. If any questions arise, contact Eaton for further information or instructions.

1-0 INTRODUCTION

General Information

The K-Frame OPTIM Series C circuit breaker types KD, HKD, and KDC are 600 VAC maximum rated devices with Digitrip OPTIM trip units rated 125A, 250A, or 400A maximum continuous current (Figure 1-1). They are for AC applications only. They are listed in accordance with Underwriters Laboratories, Inc. Standard UL 489 and satisfy the (P1) requirements of International Electrotechnical Commission Recommendations No. IEC 157-1. The OPTIM 750 and 1050 K-Frame circuit breakers are equipped with an extra auxiliary switch and alarm (signal)/lockout switch for customer usage. Other internal accessories are available but must be factory installed. Contact Eaton for the following information and user manuals:

K-Frame and Accessories Selection Data	29-120K
Instructions and Overview of	
OPTIM Trip Units	29C890
Instructionson the Operation of Digitrip	
OPTIMIZER Hand Held Programmer	29C892
Instructionson the Operation of Digitrip	
Breaker Interface Module	29C893
Instructions on the Operation of Digitrip	
OPTIM Trip Units	29C891
Digitrip OPTIM Wire Diagrams	29C894

100 Percent Rated K-Frame Circuit Breakers

CKD and CHKD circuit breakers are suitable for continuous operation at 100 percent of the frame rating if used with 90°C insulated wire and AL9CU terminals in an enclosure which measures at least 24" high x 15" wide x 6" deep. Ventilation is not required in an enclosure having these minimum dimensions.

2-0 INSTALLATION

The installation procedure consists of inspecting the circuit breaker and, as applicable, installing the rating plug and terminals; mounting the circuit breaker; connecting

the line and load conductors; torquing terminals; and attaching terminal shields. Circuit breaker frames, rating plugs, accessories, mounting hardware, and unmounted terminals may be supplied in separate packages. To install the circuit breaker, perform the following steps.

2-1. Compare nameplate data with existing equipment ratings and system requirements make sure that the circuit breaker is suitable for the intended installation. Prior to mounting, confirm that the circuit breaker has not been damaged during transit or initial handling.

2-2. Remove installed cover screws and cover.

NOTICE

The circuit breaker must be in the tripped or OFF position to remove the cover.

2-3. If not already installed, install the rating plug and, if required, accessories in the circuit breaker frame.

NOTICE

If required, internal accessory installation in any type of circuit breaker should be done before the circuit breaker is mounted and connected. Refer to individual accessory instruction leaflets.

2-4. Replace cover and install pan-head screws followed by thread-forming screws.



CAUTION

WHEN REMOVED AND REINSTALLED. THREAD FORMING SCREWS WILL TRY TO REFORM THE THREADS IN THE BASE. CARE SHOULD BE TAKEN EVERY TIME A THREAD-FORMING SCREW IS USED TO ENSURE THE SCREW STARTS IN THE ORIGINAL THREADS. DAMAGED THREADS CAN RESULT IN IMPROPER CIRCUIT BREAKER COVER RETENTION.

2-5. If not already installed, mount wire connecting terminals as shown in Figure 2-1. Secure the terminals to the circuit breaker using a 7/32 inch socket wrench. Torque to 6 to 8 lb.-ft. (8 to 11 N.m.) With the circuit breaker mounted and before the conductors are installed and conductor clamping screws inserted, the terminal mounting screws may be checked for correct

torque. If Warning Label is supplied with terminals, place Warning Label on upper portion of circuit breaker cover.



WARNING

THE VOLTAGES IN ENERGIZED EQUIPMENT CAN CAUSE DEATH OR SEVERE PERSONAL INJURY. BEFORE MOUNTING THE CIRCUIT BREAKER IN AN ELECTRICAL SYSTEM, MAKE SURE THERE IS NO VOLTAGE PRESENT WHERE WORK IS TO BE PERFORMED.

NOTICE

Depending on the equipment configuration, the circuit breaker can be mounted using different styles of hardware. The following steps describe how to mount the circuit breaker using standard hardware. When special hardware is needed (for example, with the electrical operator), the instruction leaflet describing the accessory also describes the special mounting arrangements.

2-6. To mount circuit breaker, perform the following steps:

- a. For individual surface mounting, drill mounting panel using the drilling plan shown in Figure 2-2. For panelboard mounting, only load end support mounting holes are required. For deadfront cover applications, cut out cover to correct escutcheon dimensions, see Figure 2-3. Make sure accessory wiring is accessible when the circuit breaker is mounted.
- b. Position circuit breaker on mounting surface.

NOTICE

Labels with accessory connection schematic diagrams are provided on the side of the circuit breaker. A note should be made of the diagrams if the labels cannot be seen when the circuit breaker is mounted.

- c. Install circuit breaker mounting screws and washers. Tighten screws firmly, but do not exceed 28 lb.-in. (3 N.m.).

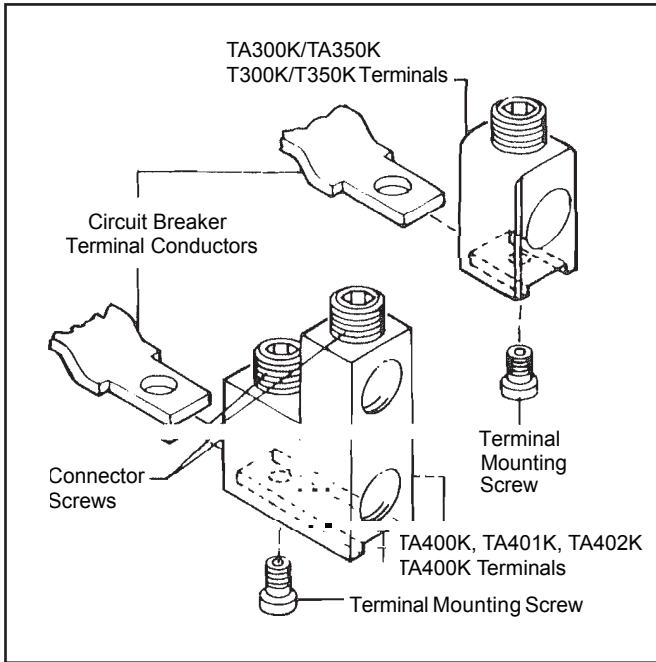

Figure 2-1 Terminal Installation

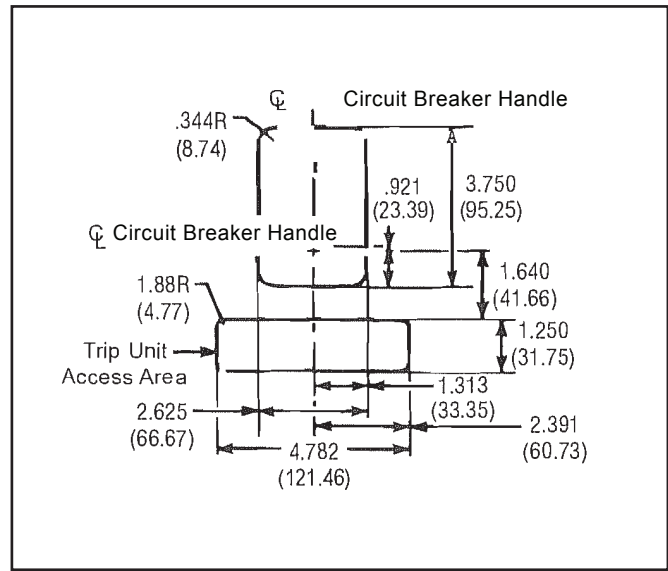

Figure 2-3 Circuit Breaker Escutcheon Cutout Dimensions for 3- and 4-Pole Circuit Breakers

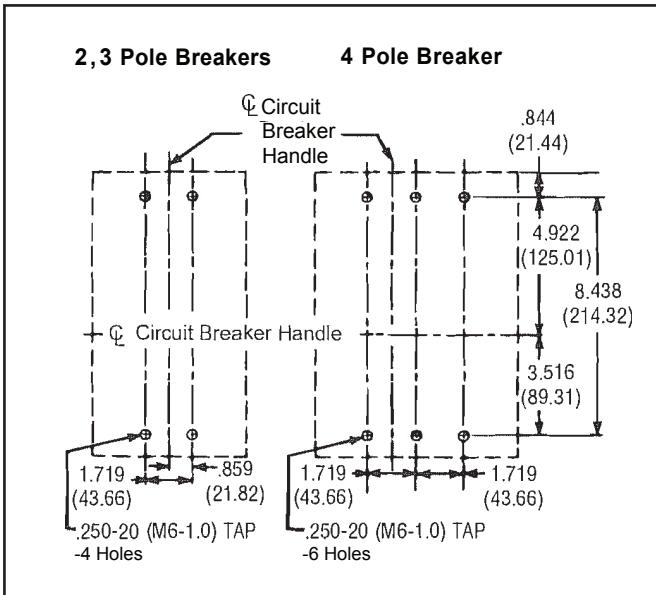

Figure 2-2 Circuit Breaker Mounting Bolt Drilling Plans

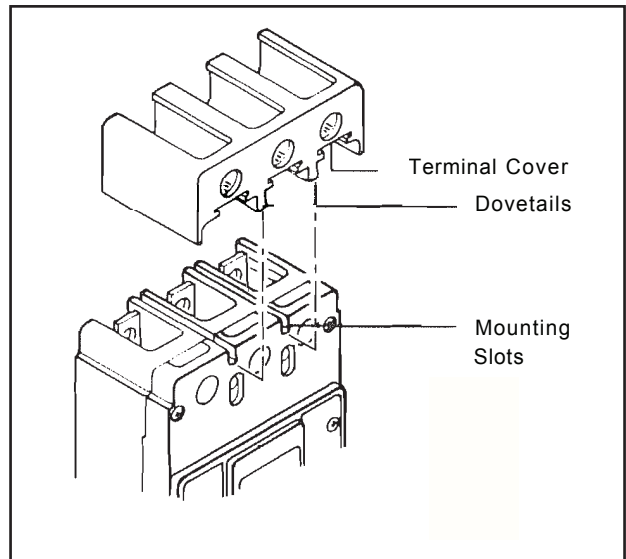
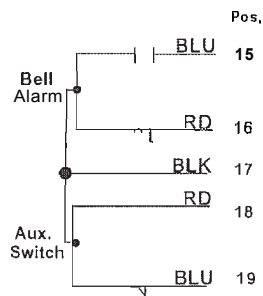

Figure 2-4 Terminal Cover Installation

Pos.	Terminal	Wire Color	Description		550 ICK	Zone Interlock	Zone w/Powernet
1	GF AL	White/Brown	GF Alarm			X	X
2	Zone OUT	White/Black	Short Delay/Ground Output	Zone		X	X
3	Zone IN	White/Red	Short Delay/Ground Input	Zone Select ④ Interlock		X	X
4	COM	(imp)	Common			X	X
5	NEG	Black*	24 V Neg*	Control ① Power	X		
6	+24Vdc	Orange*	24 Vdc* Power Supply*		X		X
7	NS	White	Neutral Sensor Non-Polarity		X	X	X
8	NS*	Gray	Neutral Sensor Polarity ②		X	X	X
9	ØC	Blue	ØC	PT Module Inputs			
10	ØB	Yellow	ØB				
11	ØA	Red	ØA				
12	INCOM	Violet	INCOM	PowerNet	X		X
13	INCOM	Violet	INCOM		X		X
14	Shield	N/A	Shield				
15	Bell N.O.	Blue	Bell Alarm N.O.				
16	Bell N.C.	Red	Bell Alarm N.C.				
17	Com	Black	Bell/Aux Common				
18	Aux N.O.	Red	Aux Switch N.O.				
19	Aux N.C.	Blue	Aux Switch N.C.				
20	Spare						
21	Spare						
22	Spare						



The combination Bell Alarm / Auxiliary Switch is only available on the OPTIM 1050 units.

NOTICE

1. It is crucial to connect the +24 VDC power supply to the correct terminal. Improper connection can destroy the electronic protection functions of the circuit breaker. The trip unit imposes a load of 45 ma.
2. The OPTIM 550 Ground Fault Trip and Ground Fault Alarm units have "NS and NS*" wires. The Non-Ground Fault Optim 550 units have no wires.
3. Customer wiring connections are made on the removable male plug of the terminal block.
4. If the customer requires the interlock feature in their system then the removal of the jumper between positions 2 & 3 is required. Breaker is shipped as self interlocked from the factory.

Figure 2-5 OPTIM Wiring Terminations

Table 2-1 Terminal Types

Terminal Cat. No.	Terminal Material Body	Screw Head Type	AWG Wire Range	Metric Wire Range	Wire Type	Torque Value lb-in (N.m.)
TA300K	Aluminum	Socket	3-350(1)	35-185	Cu/Al	275 (31)
TA350K	Aluminum	Socket	250-500(1)	120-240	Cu/Al	375 (42)
TA400K	Aluminum	Socket	3/0-250(2)	95-120(2)	Cu/Al	275 (31)
TA401K	Aluminum	Socket	250(2)	120(2)	Cu/Al	275 & 375 (31 & 42)
			or 500(1)	or 240(1)	Cu/Al	375 (42)
TA402K	Aluminum	Socket	500-750(1)	240-300	Cu/Al	550 (62)
T300K	Copper	Socket	3-350(1)	35-185	Cu Only	275 (31)
T350K	Copper	Socket	250-500(1)	120-240	Cu Only	375 (42)
T400K	Copper	Socket	3/0-250(2)	95-120(2)	Cu Only	275 (31)



CAUTION

WHEN ALUMINUM CONDUCTORS ARE USED, THE APPLICATION OF A SUITABLE JOINT COMPOUND IS RECOMMENDED TO REDUCE THE POSSIBILITY OF TERMINAL OVERHEATING. OVERHEATING CAN CAUSE NUISANCE TRIPPING AND DAMAGE TO THE CIRCUIT BREAKER.

2-7. Connect line and load conductors and accessory leads.

NOTICE

When a dual conductor terminal (Catalog No. TA402K, TA401K, TA400K or T400K) is installed on the circuit breaker and a single conductor is used, the conductor should be installed in the terminal opening nearest to the circuit breaker terminal mounting conductor.

2-8. Install the supplied neutral current sensor in the neutral pole of a four-wire system, see Figure 2-6.

2-9. After the circuit breaker is installed, check all mounting hardware and terminal connecting hardware for correct torque loading. Torque values for line/load terminals are given in Table 2-1 and on the circuit breaker nameplate.

2-10. If required, install line terminal cover on circuit breaker cover with mounting slots provided.

Table 2-2 Rating Plugs

Trip Unit Rating	Available Rating Plugs
125A	63A, 70A, 90A, 100A, 110A, 125A
250A	125A, 150A, 160A, 175A, 200A, 225A, 250A
400A	200A, 225A, 250A, 300A, 350A, 400A

2-11. When step-type terminals (TA400K, TA401K, TA402K or T400K) are used, terminal shields (supplied with terminals) must be installed on the circuit breaker (Figure 2-4). Warning label supplied with the kit must be attached to the circuit breaker cover.



WARNING

HAZARDOUS VOLTAGE CONDITIONS CAN CAUSE DEATH OR SEVERE PERSONAL INJURY. MAINTAIN ORIGINAL ELECTRICAL CLEARANCE AND CREEPAGE SPACINGS AT TERMINATIONS.

2-12. Connect the control wires and power wires to their appropriate locations on the male plug of the terminal block, see Figure 2-5. Control power is necessary if IMPACC communication is required.

2-13. Install an appropriate rating plug, see Table 2-2.

2-14. Plug in the hand held Digitrip OPTIMIZER into the programming port and set the INCOM address. Then set the various trip unit current settings using the OPTIMIZER, or when INCOM is available, use the circuit

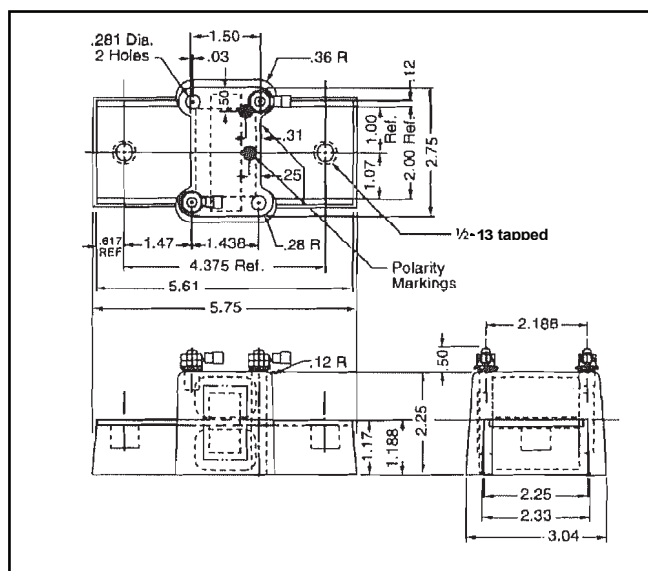

Figure 2-6 Neutral Sensor Dimensions

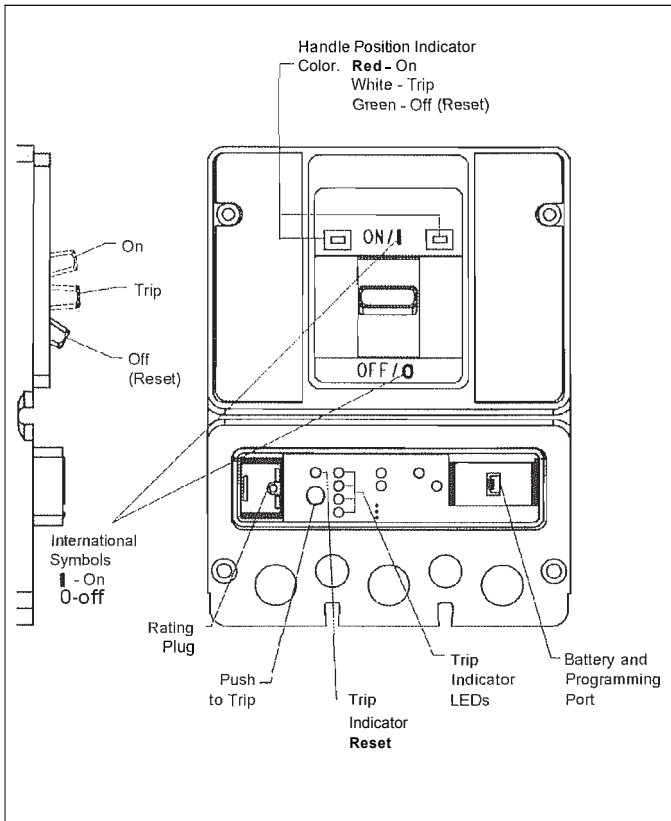

Figure 3-1 Circuit Breaker

breaker interface module. If IMPACC Series III software is part of the system, this too can be used to set the trip unit settings. Refer to the user manuals for details.

3-0 MANUAL OPERATION

Manual operation of the circuit breaker is controlled by the circuit breaker handle and the PUSH-TO-TRIP button in the trip unit. The circuit breaker handle has three positions, two of which are shown on the cover with raised lettering to indicate ON and OFF. On the handle, ON, OFF, and trip are also shown by a color-coded strip for each circuit breaker handle position: red for ON, white for tripped, and green for OFF (see Figure 3-1).

Circuit Breaker Reset

After a trip operation, the circuit breaker is reset by moving the circuit breaker handle to the Reset (extreme OFF) position. It is not necessary to press the reset button before resetting the breaker. The reset button affects only the cause of trip indicator LED's. It does not affect the operation of the circuit breaker itself.

NOTICE

No circuit breaker should be reclosed until the cause of trip is known and the situation rectified.

PUSH-TO-TRIP Button

The PUSH-TO-TRIP button operates the circuit breaker tripping function and may be used to periodically exercise the operating mechanism. The button is designed to be operated by a small screwdriver.

4-0 INSPECTION AND FIELD TESTING

Series C molded case circuit breakers are designed to provide years of almost maintenance-free operation. The following procedure describes how to do a limited amount of field inspection and testing of a circuit breaker.

Inspection

Circuit breakers in service should be inspected periodically. The inspection should include the following checks 4-1 through 4-7.



WARNING

THE VOLTAGES IN ENERGIZED EQUIPMENT CAN CAUSE SEVERE PERSONAL INJURY OR DEATH. BEFORE INSPECTING THE CIRCUIT BREAKER IN AN ELECTRICAL SYSTEM, MAKE SURE THE CIRCUIT BREAKER IS SWITCHED TO THE OFF POSITION AND THAT THERE IS NO VOLTAGE PRESENT WHERE WORK IS TO BE PERFORMED.



CAUTION

SOME COMMERCIAL CLEANING AGENTS WILL DAMAGE THE NAMEPLATES OR MOLDED PARTS. MAKE SURE THAT THE CLEANING AGENTS OR SOLVENTS USED TO CLEAN THE CIRCUIT BREAKER ARE SUITABLE FOR THE JOB.

4-1. Remove dust, dirt, soot, grease, or moisture from the surface of the circuit breaker using a lint-free dry cloth, brush, or vacuum cleaner. Do not blow debris into

circuit breaker. If contamination is found, look for the source and eliminate the problem.

4-2. Switch circuit breaker to ON and OFF several times to be sure that the mechanism linkages operate freely and do not bind. If mechanical linkages do not operate freely, replace circuit breaker.

4-3. With the circuit breaker in the ON position, press the PUSH-TO-TRIP button to mechanically trip the circuit breaker. Trip, reset, and switch circuit breaker ON several times. If mechanism does not reset each time the circuit breaker is tripped, replace the circuit breaker.

4-4. Check base, cover, operating handle, and handle barrier, for cracks, chipping, and discoloration. Circuit breakers should be replaced if cracks or severe discoloration is found.

4-5. Check wire connecting terminals and other type bus bar connectors for looseness or signs of overheating. Overheating will show as discoloration, melting, or blistering of conductor insulation, or as pitting or melting of conductor surfaces due to arcing. If there is no evidence of overheating or looseness, do not disturb or tighten the connections. If there is evidence of overheating, terminations should be cleaned or replaced. Before re-energizing the circuit breaker, all terminations and cable should be refurbished to the originally installed condition.

4-6. Check circuit breaker mounting hardware, and tighten if necessary.

4-7. Exposure to certain types of chemicals can cause deterioration of electrical connections. Check area where circuit breaker is installed for any safety hazards, including personal safety and fire hazards and take required precautionary actions.

Field Testing

Any field testing should be done in accordance with applicable NEMA Standard. The operation of circuit breakers with Digitrip OPTIM trip units can be field tested periodically using the hand held OPTIMIZER (see user manuals).

Performance Testing for Ground Fault Trip Units

Code Requirements

The National Electrical Code under Article 230-95-C requires that any ground-fault protection system be performance tested when first installed. The test shall be conducted in accordance with approved instructions provided with the equipment. A written record of this

test shall be made and shall be available to the authority having inspection jurisdiction.

Standards Requirements

As a follow-up to the basic performance requirements stipulated by the N.E.C. as stated above, UL Standard No. 1053 requires that certain minimum instructions must accompany each ground fault protection system. These following statements plus a copy of the test record form illustrated in Figure 4-1 are shipped with each Digitrip OPTIM trip unit.

General Test Instructions

The interconnected system shall be evaluated in accordance with the equipment assembler's detailed instructions by qualified personnel.

The polarity of the neutral sensor connections (if used) must agree with equipment assembler's detailed instructions to avoid improper operations following apparently correct simulated test operations. Where a question exists, consult the specifying engineer and/or equipment assembler.

The grounding points of the system shall be verified to determine that ground paths do not exist that would bypass the sensors. The use of high-voltage testers and resistance bridges may be used.



WARNING

THERE IS A HAZARD OF ELECTRICAL SHOCK OR BURN WHENEVER WORKING IN OR AROUND ELECTRICAL EQUIPMENT. ALWAYS TURN OFF POWER SUPPLYING BREAKER BEFORE CONDUCTING TESTS.

NOTICE

Since Digitrip OPTIM trip units derive their operating power from the phase currents, and not from the neutral current, passing current through the neutral sensor only will not properly test the ground fault feature.

Using a low-voltage (0-24 volt), high current, ac source, apply a test current of 125% of the Digitrip OPTIM Ground Fault Trip Unit pick-up setting through one phase of the circuit breaker, as shown in Figure 4-2. This should cause the breaker to trip in less than 1 second, and if an alarm indicator is supplied, it should operate. Reset the breaker and the alarm indicator. Repeat the test on the other two phases.

If the system is a 4-wire system with a neutral current sensor, apply the same current as described above

through one phase of the breaker, returning through the neutral sensor, as shown in Figure 4-3. The breaker should not trip, and the alarm indicator, if supplied, should not operate. Repeat the test on the other two phases.

If the system is a 3-wire system with no neutral current sensor, apply the same current as described above through any two phases of the breaker, with the connections exactly as shown in Figure 4-4. The breaker should not trip, and the alarm indicator, if supplied, should not operate. Repeat the test using the other two combinations of breaker phases.



CAUTION

FIELD TESTING SHOULD BE USED FOR FUNCTIONAL TESTING AND NOT FIELD CALIBRATION OF THE DIGITRIP OPTIM GROUND FAULT TRIP UNIT.

ANY TEMPORARY CONNECTION MADE FOR THE PURPOSE OF CONDUCTING TESTS SHOULD BE RESTORED TO PROPER OPERATING CONDITION BEFORE RETURNING THE BREAKER TO SERVICE.

The results of the test are to be recorded on the test form provided with the equipment.

GROUND FAULT TEST RECORD FORM			
Ground Fault Test Records should be Retained by Those in Charge of the Building's Electrical Installation in order to be available to the Authority having Jurisdiction.			
Test Date	Circuit Breaker Number	Results	Tested By

Figure 4-1 Typical Performance Test Record Form

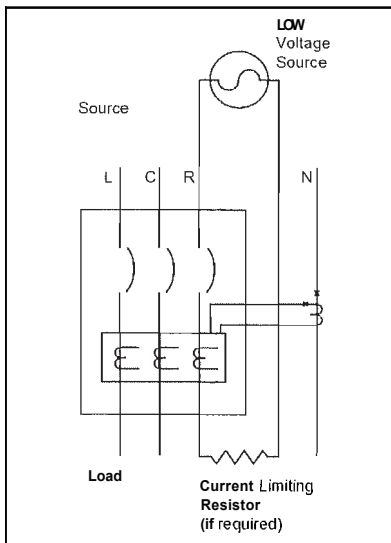

Figure 4-2 Connections for Ground Fault Trip Test

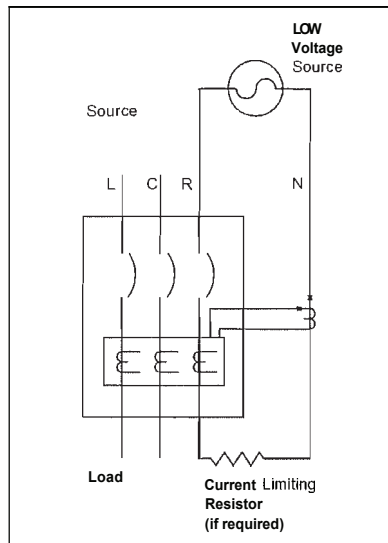

Figure 4-3 Connections for Ground Fault No-Trip Test, with a Four-Wire System

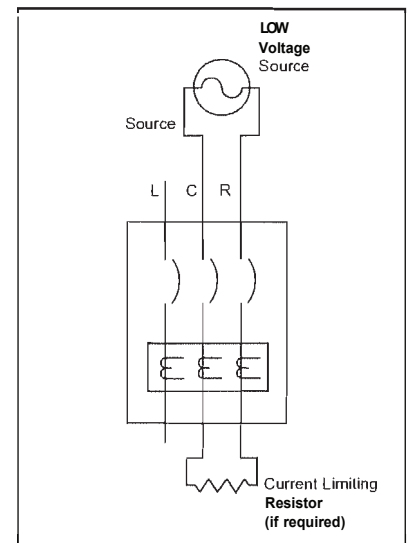

Figure 4-4 Connections for Ground Fault No-Trip Test, with a Three-Wire System

Notes:

Notes:

The instructions for installation, testing, maintenance, or repair herein are provided for the use of the product in general commercial applications and may not be appropriate for use in nuclear applications. Additional instructions may be available upon specific request to replace, amend, or supplement these instructions to qualify them for use with the product in safety-related applications in a nuclear facility.

This Instruction Booklet is published solely for information purposes and should not be considered all-inclusive. If further information is required, you should consult an authorized Eaton sales representative.

The sale of the product shown in this literature is subject to the terms and conditions outlined in appropriate Eaton selling policies or other contractual agreement between the parties. This literature is not intended to and does not enlarge or add to any such contract. The sole source governing the rights and remedies of any purchaser of this equipment is the contract between the purchaser and Eaton.

NO WARRANTIES, EXPRESSED OR IMPLIED, INCLUDING WARRANTIES OF FITNESS FOR A PARTICULAR PURPOSE OR MERCHANTABILITY, OR WARRANTIES ARISING FROM COURSE OF DEALING OR USAGE OF TRADE, ARE MADE REGARDING THE INFORMATION, RECOMMENDATIONS, AND DESCRIPTIONS CONTAINED HEREIN.

In no event will Eaton be responsible to the purchaser or user in contract, in tort (including negligence), strict liability or otherwise for any special, indirect, incidental or consequential damage or loss whatsoever, including but not limited to damage or loss of use of equipment, plant or power system, cost of capital, loss of power, additional expenses in the use of existing power facilities, or claims against the purchaser or user by its customers resulting from the use of the information, recommendations and description contained herein.

Eaton Corporation
Electrical Group
1000 Cherrington Parkway
Moon Township, PA 15108
United States
877-ETN-CARE (877-386-2273)
Eaton.com

© 2011 Eaton Corporation
All Rights Reserved
Printed in USA
Publication No. IL29C092E /TBG000630
Part No. 6602C31H06
November 2013