

Nellie's®
FOAMING DISPENSER
DISTRIBUTEUR MOUSSANT



CONTENTS

- 3 ... Foaming Dispenser Components
- 4 ... Installation
- 5 ... Assembly
- 6 ... Instructions for Use
- 8 ... Operation Tips



KEEP YOUR HANDS
CLEAN. STAY SAFE!

FOAMING DISPENSER COMPONENTS

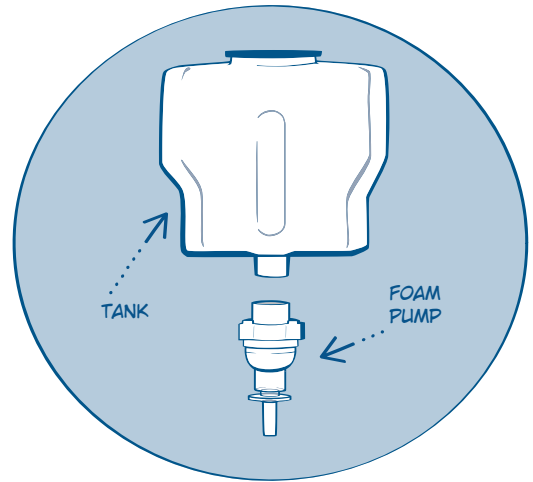
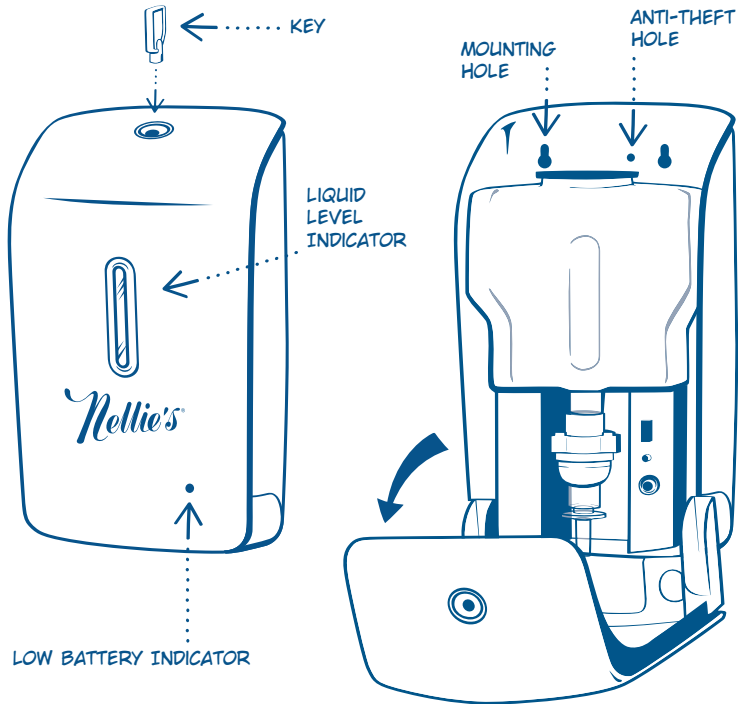

4 INSTALLATION

Installing on a Wall

Choose an appropriate place to install the dispenser and keep at least 20 cm of free space below it.

Use the key to unlock and open the front cover then remove the tank and pump.

Make drilling marks, drill the holes and insert the plastic anchors.

Secure the dispenser onto the wall with screws.

Note:

- Use the anti-theft hole if the dispenser is installed in a public place.

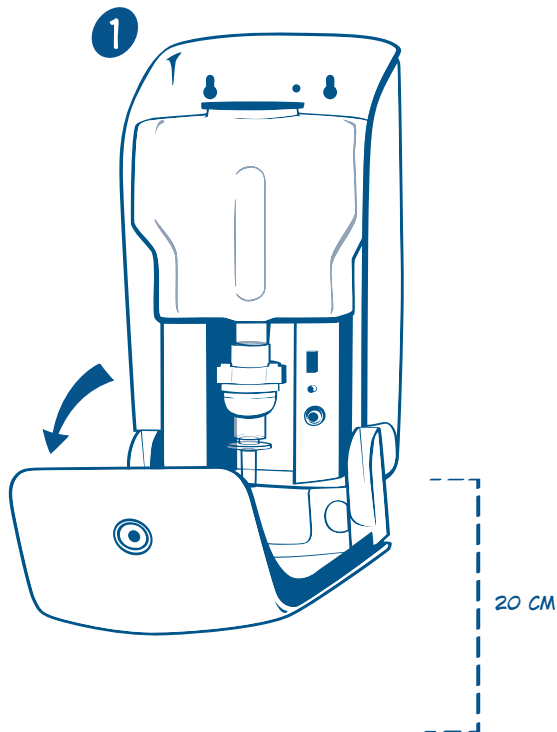

2

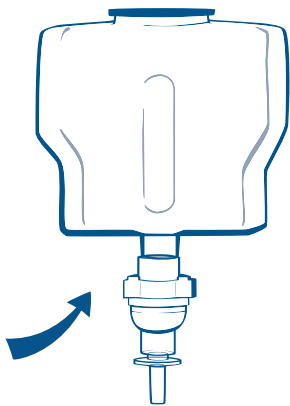
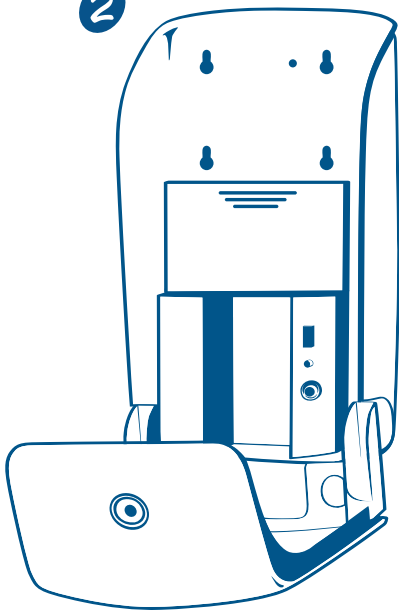

3

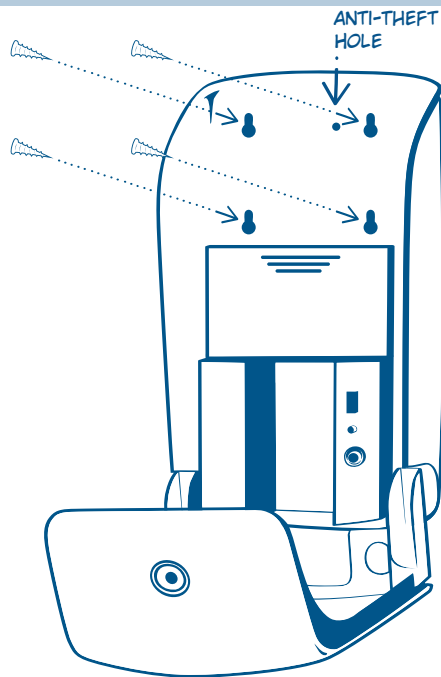

6 INSTRUCTIONS FOR USE

Setting Up

Slide the lid of the battery box and place 4 C-size batteries or use an AC/DC adaptor*.

Put the tank and pump back into the dispenser.

Fill the tank with Alcohol-Free Nellie's Hand Sanitizer or Nellie's One Soap and slide the switch to ON. Close the front cover.

Notes:

- Do not use batteries if an AC/DC adaptor is plugged in.

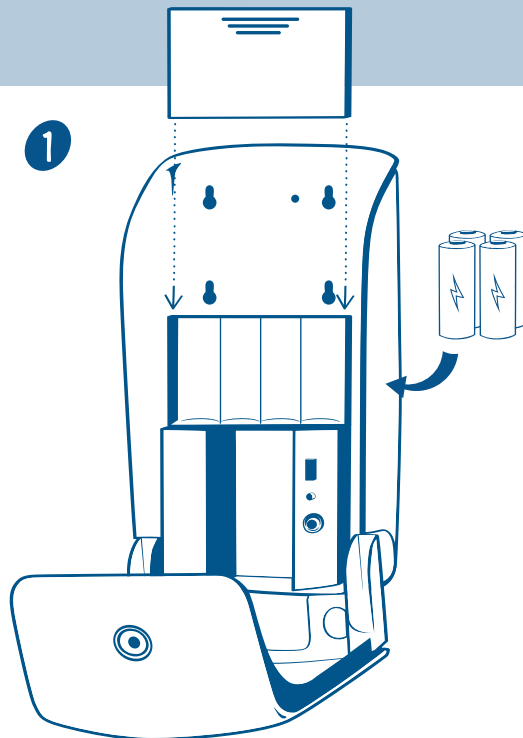

*AC/DC adaptor sold separately.



3

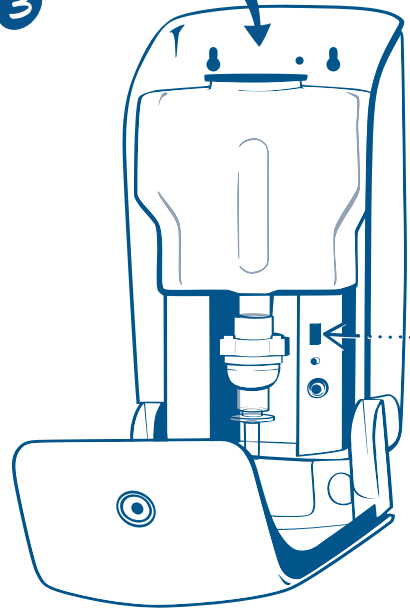

ON/OFF SWITCH

2

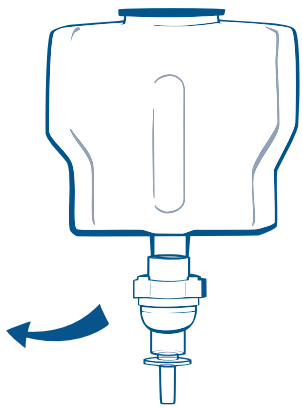
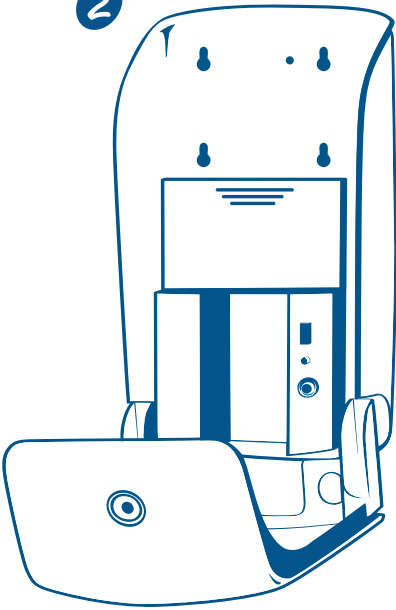

8 OPERATION TIPS

Using the Foaming Dispenser

Place your hand under the sensor area to activate the dispenser until the liquid comes out.

Nellie's Foaming Dispenser is for indoor use only. Place it in a cool area and avoid direct sunlight or heat.

Low Battery Indicator

A red LED light blinks when the batteries need to be changed.

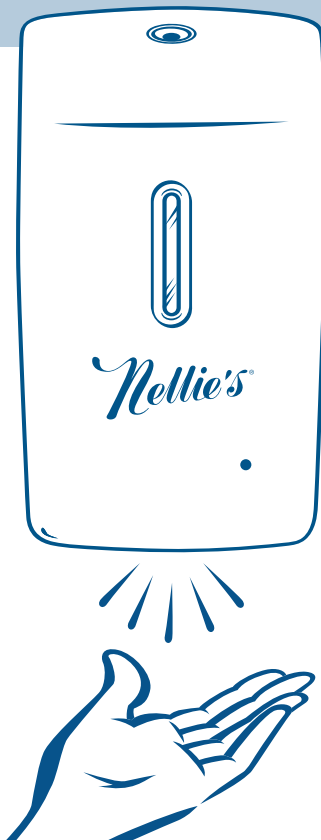

Technical Parameters

Power Supply	4 x C-size Batteries
Optional Power Supply	AC/DC Adaptor
Sensor Type	Touchless Sensor
Sensor Range	50-120 mm
Tank Volume	1 L

Nellie's

114-2455 Dollarton Hwy, North Vancouver,
BC, Canada V7H 0A2
nelliesclean.com