

Performance Curves

Model **MATRIX**

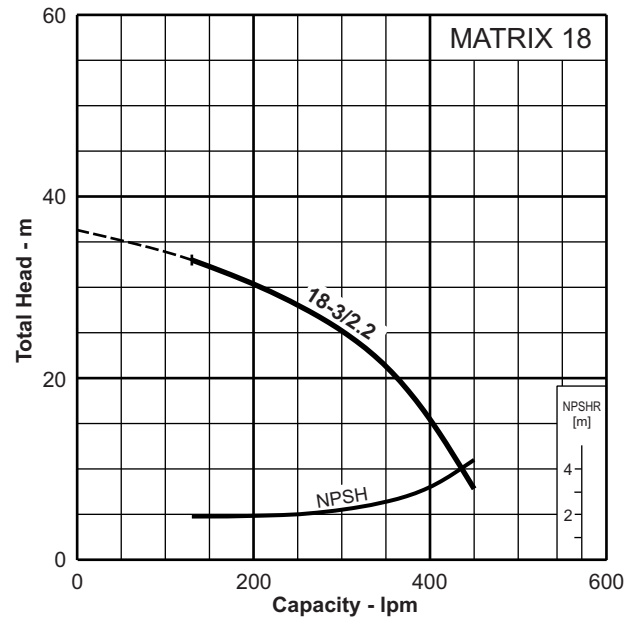
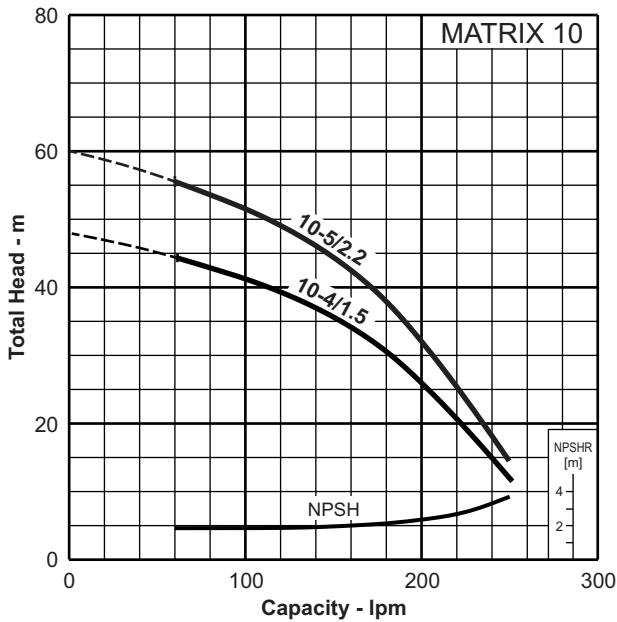
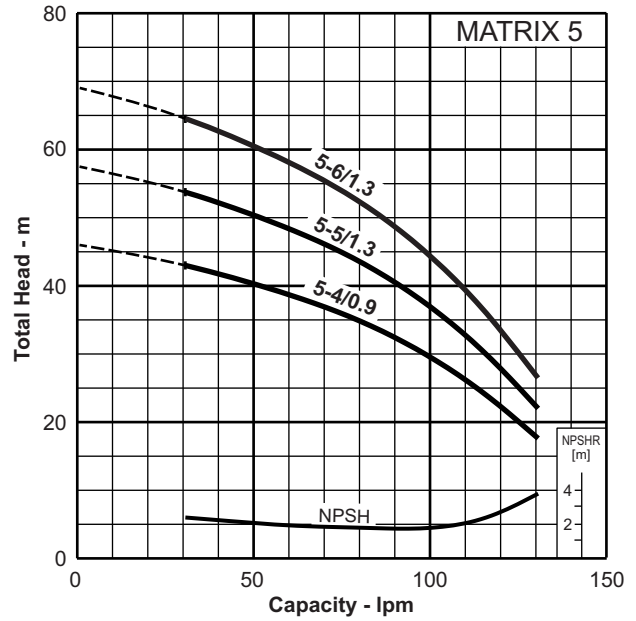
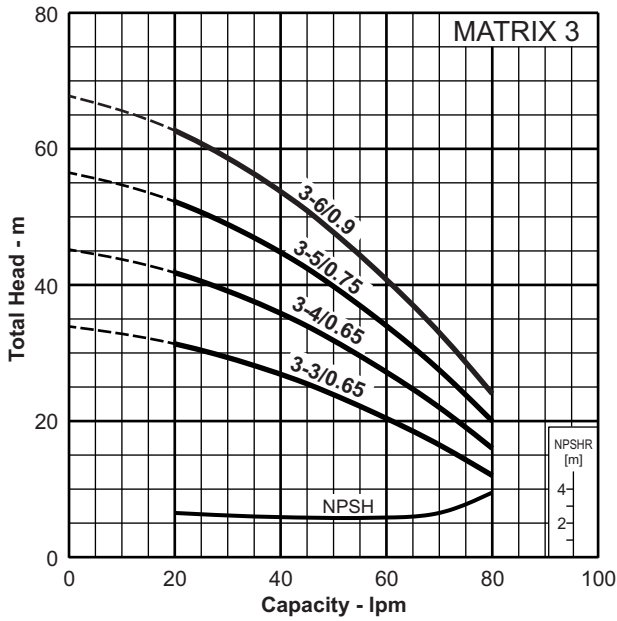

Motor & Noise Data

Model **MATRIX**

* Mean value of several values at 1m distance around the pump. Tolerance ± 2.5 dB.

Pump Model	Motor Output kW	Capacitor		Input Power kW	Full Load Current Amps	Locked Rotor Current Amps	Motor Size	Bearings		Noise Data LpA-dB(A)*
		μ F	Vc					Pump Side	Fan Side	
MATRIX 3-3T/0.65M	0.65 kW	16 μ F	450	0.97	4.5 A	16.2 A	71	6203-2RSH-C3	6202-2RSH	62
MATRIX 3-4T/0.65M	0.65 kW	16 μ F	450	0.97	4.5 A	16.2 A	71	6203-2RSH-C3	6202-2RSH	62
MATRIX 3-5T/0.75M	0.75 kW	25 μ F	450	1.14	5.4 A	26.5 A	71	6203-2RSH-C3	6202-2RSH	62
MATRIX 3-6T/0.9M	0.9 kW	31.5 μ F	450	1.28	5.7 A	21.7 A	71	6203-2RSH-C3	6202-2RSH	62
MATRIX 5-4T/0.9M	0.9 kW	31.5 μ F	450	1.28	5.7 A	21.7 A	71	6203-2RSH-C3	6202-2RSH	62
MATRIX 5-5T/1.3M	1.3 kW	31.5 μ F	450	1.75	7.8 A	39.0 A	80	6304-2RSH-C3	6203-2RSH	64
MATRIX 5-6T/1.3M	1.3 kW	31.5 μ F	450	1.75	7.8 A	39.0 A	80	6304-2RSH-C3	6203-2RSH	64
MATRIX 10-4T/1.5M	1.5 kW	35 μ F	450	1.95	8.7 A	40.9 A	80	6304-2RSH-C3	6203-2RSH	64
MATRIX 10-5T/2.2M	2.2 kW	50 μ F	450	2.92	13 A	62.4 A	90	6305-2RSH1-C3	6205-2RSH-C3	68
MATRIX 18-3T/2.2M	2.2 kW	50 μ F	450	2.92	13 A	62.4 A	90	6305-2RSH1-C3	6205-2RSH-C3	68

Dimensions

Model **MATRIX**

Units: mm unless otherwise specified

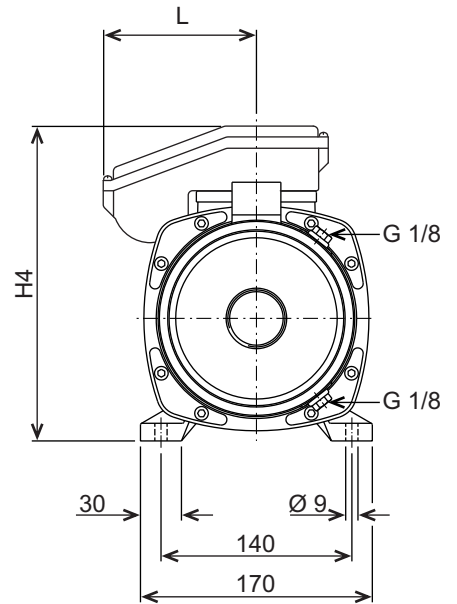
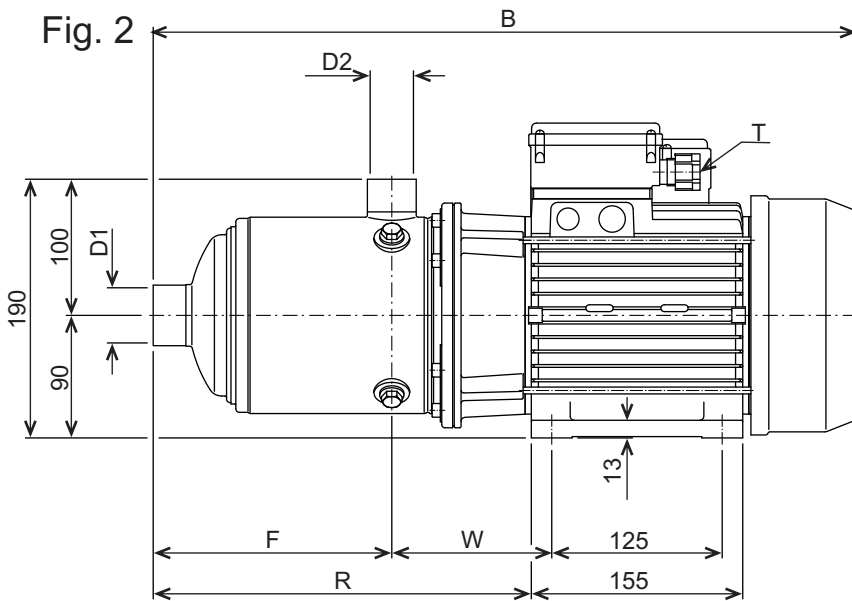
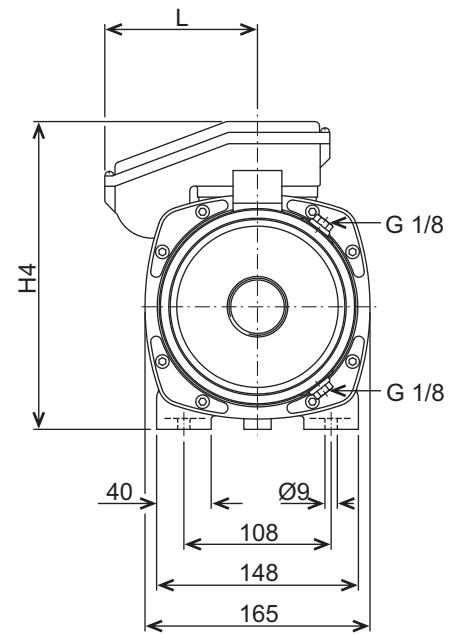
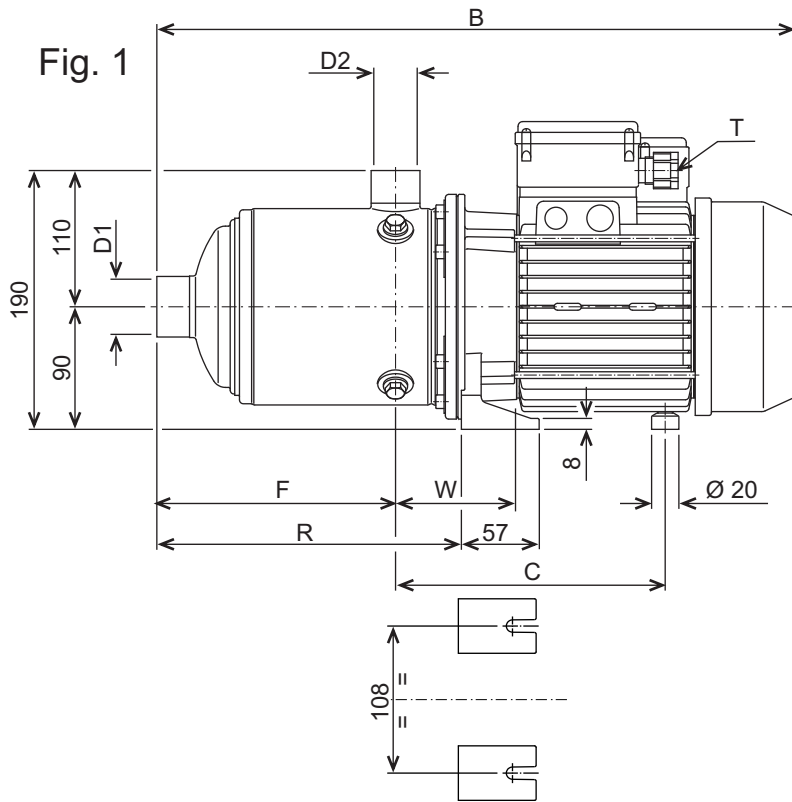

Pump Model	Drg.	Dimensions										Weight
		D1	D2	B	C	F	H4	L	R	T	W	
MATRIX 3-3T/0.65M	Fig. 1	1"	1"	360	171	103	200	86.5	151.5	PG11	88~97	9.9 kg
MATRIX 3-4T/0.65M				384	171	127	200	86.5	175.5	PG11	88~97	10.6 kg
MATRIX 3-5T/0.75M				408	171	151	200	86.5	199.5	PG11	88~97	12.5 kg
MATRIX 3-6T/0.9M				432	171	175	219	106	223.5	PG11	88~97	13.7 kg
MATRIX 5-4T/0.9M	Fig. 1	1 1/4"	1"	384	171	127	219	106	175.5	PG11	88~97	12.2 kg
MATRIX 5-5T/1.3M				445	198	151	226	112	199.5	M20x1.5	88~97	15.0 kg
MATRIX 5-6T/1.3M				469	198	175	226	112	223.5	M20x1.5	88~97	15.2 kg
MATRIX 10-4T/1.5M	Fig. 1	1 1/2"	1 1/4"	446	202	148	226	112	200.5	M20x1.5	92~101	15.6 kg
MATRIX 10-5T/2.2M	Fig. 2			524	-	178	231	112	284.5	M20x1.5	121.5	21.3 kg
MATRIX 18-3T/2.2M	Fig. 2			490	-	141	231	112	250.5	M20x1.5	124.5	20.6 kg

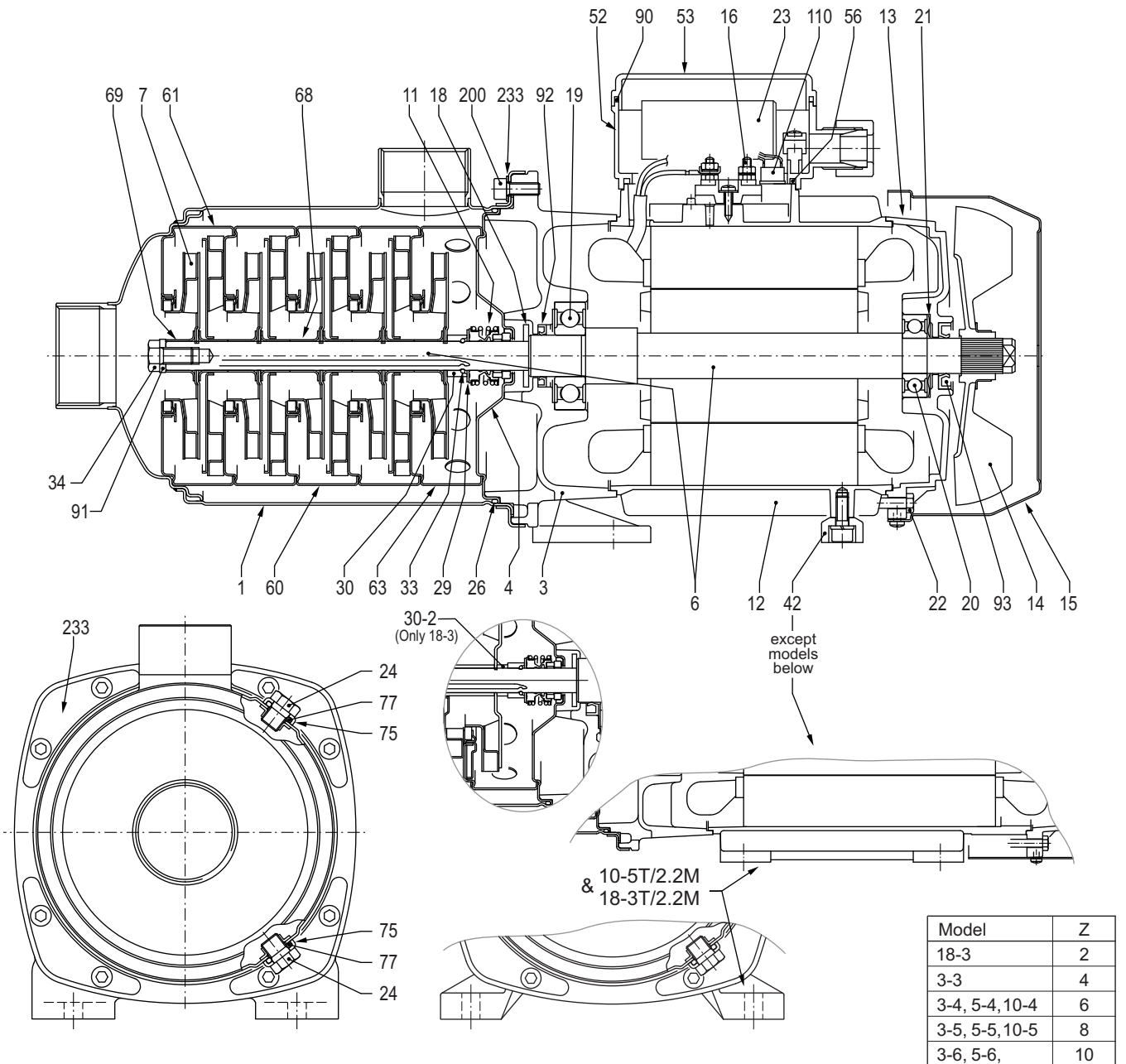

* - refer to table above

No.	Description	Material	Qty.	No.	Description	Material	Qty.	No.	Description	Material	Qty.
1	Casing	304 S/Steel	1	21	Adjusting ring	Steel C70	1	60	Intermediate casing	304 S/Steel	[N-2]
3	Bracket	Aluminium	1	22	Tie rod	Fe 420 (Gal)	4	61	Inter. casing (suction)	304 S/Steel	1
4	Casing cover	304 S/Steel	1	23	Capacitor	-	1	63	Inter. casing (discharge)	304 S/Steel	1
6	Shaft with rotor	304 S/St. (In contact with liquid)	1	24	Plug (Drain & Fill)	304 S/Steel	2	68	Shaft sleeve (intermediate)	304 S/Steel	Z*
7	Impeller	304 S/Steel	[N]	26	O-Ring	EPDM	1	69	Impeller spacer	304 S/Steel	1
11	Mechanical seal	Carbon/Ceramic/EPDM	1	29	Washer	304 S/Steel	1	75	Washer (plug)	304 S/Steel	2
12	Motor frame & stator	-	1	30	Ring holder	304 S/Steel	1	77	O-Ring (plug)	EPDM	2
13	Motor over	Aluminium	1	30-2	Shaft sleeve	304 S/Steel	1#	90	Cover box gasket	NBR	1
14	Fan	Polyamide	1	33	Ring	304 S/Steel	2	91	Shaft washer	304 S/Steel	1
15	Fan cover	Fe P04 (Gal)	1	34	Screw	304 S/Steel	1	92	Lip seal	-	1
16	Terminal board	-	1	42	Foot	Aluminium	1#	93	Lip seal	-	1
18	Splash ring	NBR	1	52	Terminal box	ABS	1	110	Protector	-	1+
19	Bearing (Pump side)	-	1	53	Terminal box cover	ABS	1	200	Screw	304 S/Steel	8
20	Bearing (Fan side)	-	1	56	Box gasket	NBR	1	233	Plate	304 S/Steel	4

[N] = no. of stages

- refer to drg's above

+ - only 1.3, 1.5 & 2.2M

Specifications subject to change without notice