

UNILIFT CC



The Grundfos UNILIFT CC is a lightweight single-stage drainage pump with a semi-open impeller. They are designed for pumping drain water and grey wastewater containing particles up to a size of up to 10 mm. The suction strainer at the bottom of the pump prevents particles larger than the pump is designed for from entering. The strainer is made of stainless steel, while the main pump parts, e.g. the sleeve and pump housing, are made of moulded composite materials. The UNILIFT CC can pump down to a water level of 3 mm above the floor by removing the strainer and can be used in permanent installations or as a portable pump.



FEATURES

Prevention of backflow

The pump is supplied with an adapter and a non-return valve to prevent backflow through the pump when it stops.

Robust design

The materials of the pump ensure excellent corrosion resistance. Furthermore, the CC 7 and 9 have a built-in V-ring mechanical shaft seal which offers wear resistance and a long operating life.

Thermal overload protection

The single-phase version is effectively protected against any accidental overload, by built-in thermal protection. This means that no additional motor protection is required.

Auto-restart

In case the motor cuts out due to thermal overload, the motor automatically starts again when it has cooled to normal temperature.

Handy and easily transportable

The light weight of the pump and the carry handle mounted on the housing make it handy and easily transportable.

Automatic operation

The pump has a float switch for automatic on/off operation between two liquid levels.

Self-venting valve

The UNILIFT CC 7 features a self-venting valve. Place the pump underwater, engage the power, and relax. The self-venting valve located in the handle prevents air from getting trapped in the pump.

Good connectivity

Includes multiple adapter for thread sizes from 3/4" to 1/1/4"

APPLICATIONS

- Domestic wastewater

PERFORMANCE

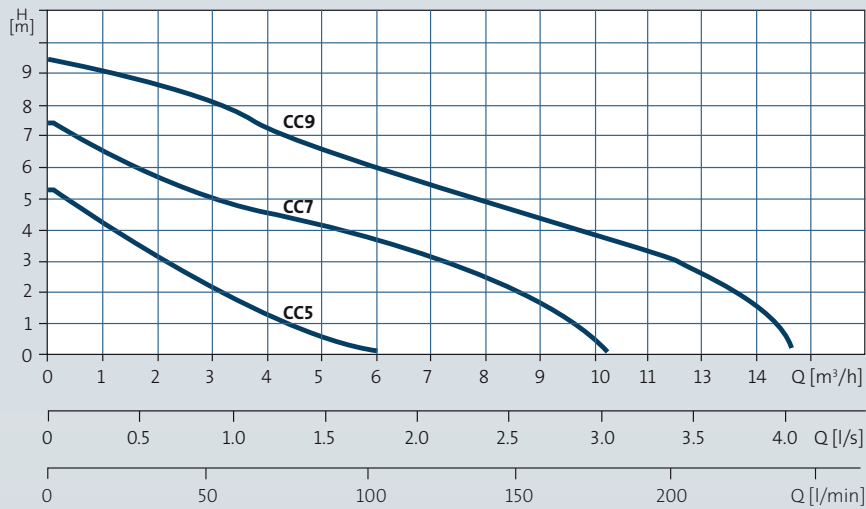

OPERATING CONDITIONS

Liquid temperature

0 °C to 40 °C

Max. particle size

Ø10 mm

pH concentration

4 to 9

Max. installation depth

10 m

TECHNICAL DATA

Mains voltage

1 x 240 V, 50 Hz

Enclosure class

IP68

Insulation class

B (UNILIFT CC 5 & CC 9)

F (UNILIFT CC 7)

Cable type

H07RN-F

Approvals and markings

VDE, CSA, GOST and LGA according to DIN EN 12050-2

DIMENSIONS

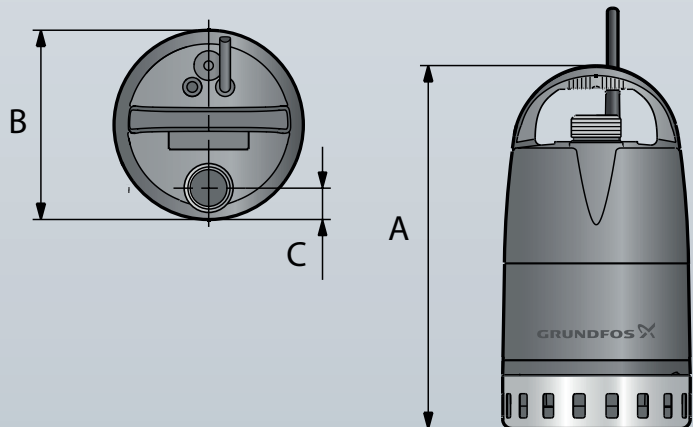

Model	Cable length (m)	Power - P2 (kW)	Connection size	Dimensions (mm)			Weight (kg)
				A	B	C	
UNILIFT CC 5	10	0.25	1¼" M	306.6	160	26.5	4.35
UNILIFT CC 7	10	0.38	1¼" M	306.6	160	26.5	4.60
UNILIFT CC 9	10	0.78	1¼" M	306.6	160	26.5	6.5