

RESILIENT SEAT BUTTERFLY VALVE

WAFER DN50 - DN300

MODEL: BFW



FEATURES AND BENEFITS

- Designed and tested in accordance with AS4795.1.
- AS4795.1 StandardsMark Certified product by SAI Global Licence No. SMK40321.
- WaterMark Approved product by SAI Global Licence No. WMK26066.
- Australian Water Quality Centre approved to AS4020.
- Bi – directional bubble tight sealing.
- Vulcanised seat held securely in position making it suitable for vacuum applications.
- High strength two piece shaft provides greater flow capabilities and eliminates pins & bolts.
- Blow-Out proof stem ensures operator safety and eliminates OH&S issues.
- Heavy duty shaft bushing ensures disc alignment & absorbs side thrusts, reducing valve wear whilst prolonging valve life.
- Suitable for high repetition, actuated applications.
- Precision disc machining ensures mirror image of seat profile enhancing low torque operation & reduced liner wear.
- ISO interface flange allows interchange and standardisation of actuation equipment.
- Stem seal connection is ensured with moulded double “O” rings, as well as an additional upper stem seal to provide greater design integrity.
- Robust, extended neck allows easy installation of insulation and ensures bearing integrity.
- Flange seal connection is ensured with moulded double “O” rings seals eliminating the requirement for flange gaskets.
- Lockable lever handle to prevent tampering.



TECHNICAL SPECIFICATION

Construction:	Wafer Concentric Seal On Body Butterfly Valve
Size:	50mm - 300mm
Pressure Rating:	PN16
Face to Face:	ISO5752 Series 20 / AS4795.1
Flange Drilling:	AS4087 PN16 (Table D) AS2129 Table E ANSI B16.5 #150
Coatings:	Fusion Bonded Epoxy AS4158
Temperature Range:	EPDM -40°C to 100°C Nitrile -10°C to 80°C
Pressure Testing:	AS4795.1
Mounting Pad:	ISO5211

APPLICATIONS

Challenger Valves and Actuators are the **“Right Choice for Valves and Actuation”** when quality matters.

Servicing industries such as:
Water & Waste Water, Mining, Desalination, Pumping, Industrial Processing, Irrigation, Materials Handling and Chemical Services.



RESILIENT SEAT BUTTERFLY VALVE

WAFER DN50 - DN300

MODEL: BFW



TECHNICAL : VALVE DETAILS

ITEM	COMPONENT	MATERIAL	GRADE
1	Body	Ductile Iron	AS1831 500-7
2	Liner	EPDM Rubber	AS1646
3	Disc	Stainless Steel	ASTM A351-CF8M
4	Upper Shaft	Stainless Steel	ASTM 276-431
5	Lower Shaft	Stainless Steel	ASTM 276-431
6	Bottom Plug	Stainless Steel	ASTM 276-304
7	Bushing	Brass	EN12164-CW614N
8	Stem Seal	NBR Rubber	AS1646
9	Top Bushing	Acetal Delrin	ASTM-D6778-06
10	Stem Washer	Stainless Steel	ASTM 182-304
11	Circlip	Stainless Steel	ASTM 182-304
*	Lever	Ductile Iron	AS1831 450-10
*	Handle	Ductile Iron	AS1831 450-10
*	Notch Plate	Stainless Steel	ASTM 182-316
*	Notch Plate Label	Aluminium	

* Parts not shown

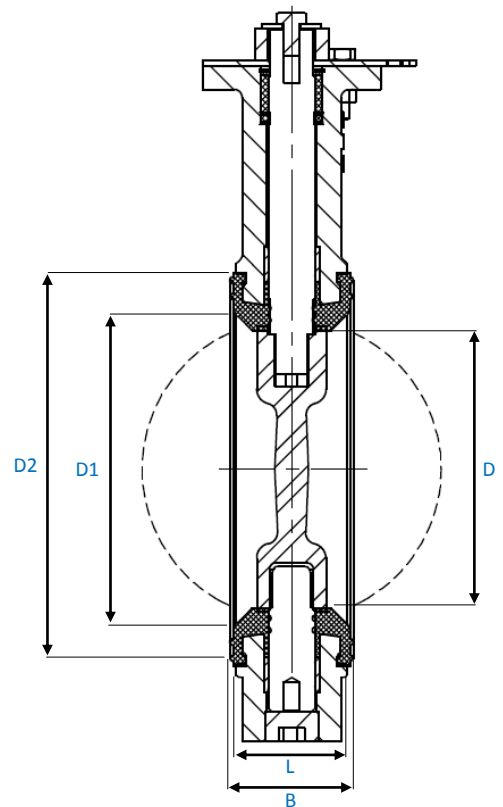
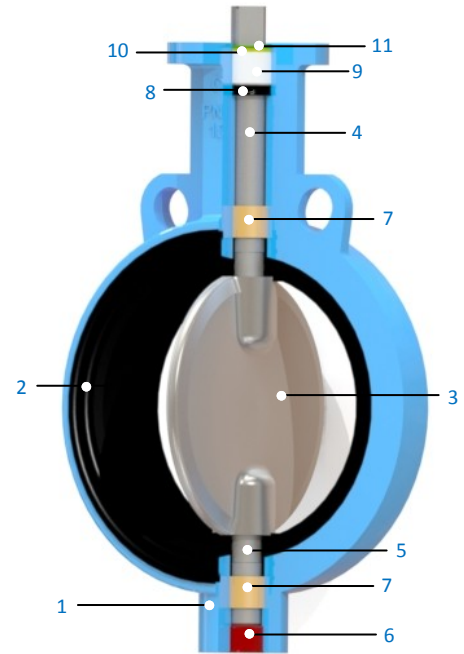
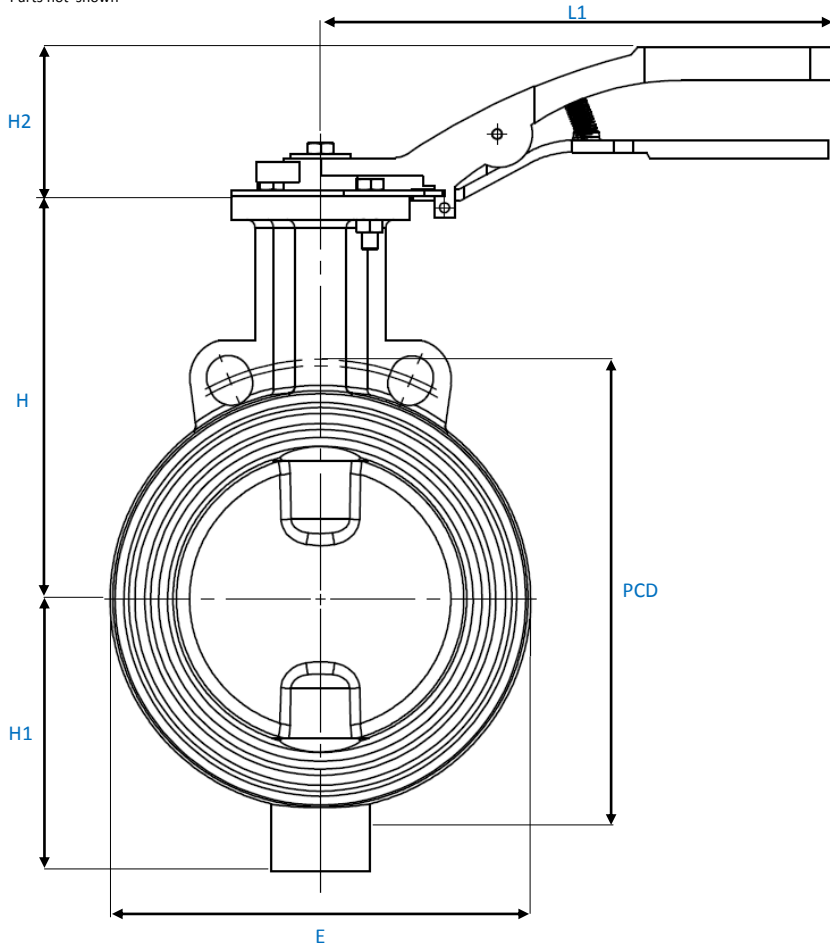

DIMENSIONS AND WEIGHTS																		
Size MM	ISO	L	B	L1	D	D1	D2	E	H	H1	H2	PCD		Nød			Weight KGs	
												Table D&E	ANSI# 150	Table D	Table E	ANSI#150	Lever Handle	Gearbox
50	F07 (70mm)	43	47	263	40	63	86	94	145	78	75	114	121	4 X M16	4 X M16	4 X UNC 5/8	3	8
65	F07 (70mm)	46	50	263	57	81	103	114	152	85	75	127	140	4 X M16	4 X M16	4 X UNC 5/8	4	9
80	F07 (70mm)	46	52	263	67	95	118	127	156	90	75	146	152	4 X M16	4 X M16	4 X UNC 5/8	5	10
100	F07 (70mm)	52	59	263	90	119	143	160	178	106	75	178	191	4 X M16	8 X M16	8 X UNC 5/8	7	13
125	F07 (70mm)	56	62	263	115	139	171	190	191	120	75	210	216	8 X M16	8 X M16	8 X UNC 3/4	9	14
150	F07 (70mm)	56	62	263	141	163	198	210	203	137	75	235	241	8 X M16	8 X M20	8 X UNC 3/4	10	15
200	F10 (102mm)	60	67	326	191	216	249	266	241	160	93	292	299	8 X M16	8 X M20	8 X UNC 3/4	17	26
250	F10 (102mm)	68	74	414	243	266	304	330	273	200	101	356	362	8 X M20	12 X M20	12 X UNC 7/8	26	35
300	F10 (102mm)	78	87	414	291	323	356	375	311	233	101	406	432	12 X M20	12 X M24	12 X UNC 7/8	41	50

**RESILIENT SEAT BUTTERFLY VALVE
 WAFER DN50 - DN300
 MODEL: BFW**



GEARBOX & BARE SHAFT DETAILS

GEARBOX

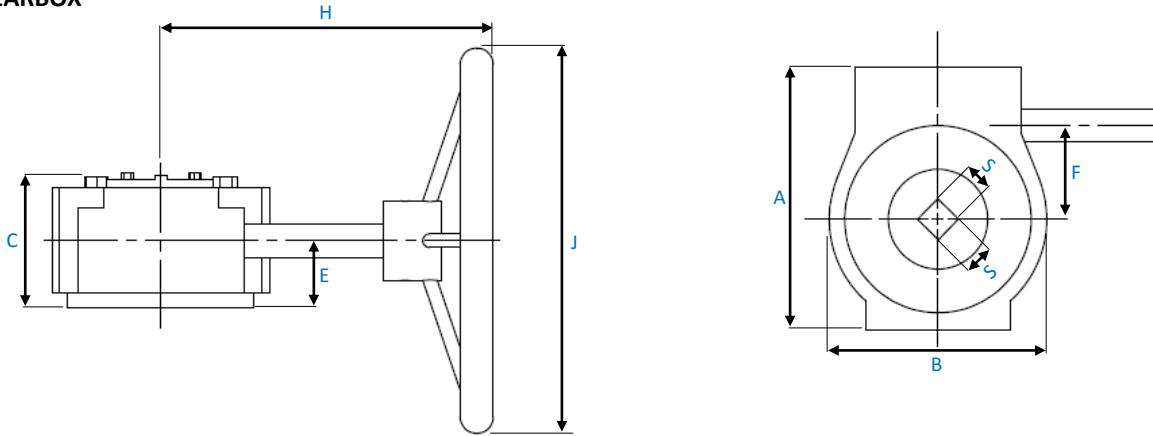

DIMENSIONS—GEARBOX											
Size MM	ISO	S	A	B	C	E	F	H	J	Ratio (:1)	No. Turns to Open/Close
50	F07 (70mm)	11	126	105	65	33	45	162	186	24	6
65	F07 (70mm)	11	126	105	65	33	45	162	186	24	6
80	F07 (70mm)	11	126	105	65	33	45	162	186	24	6
100	F07 (70mm)	14	126	105	65	33	45	162	186	24	6
125	F07 (70mm)	14	126	105	65	33	45	162	186	24	6
150	F07 (70mm)	17	126	105	65	33	45	162	186	24	6
200	F10 (102mm)	17	176	152	83	41	66	246	294	30	7.5
250	F10 (102mm)	22	176	152	83	41	66	246	294	30	7.5
300	F10 (102mm)	22	197	161	90	48	78	236	294	50	12.5

BARE SHAFT

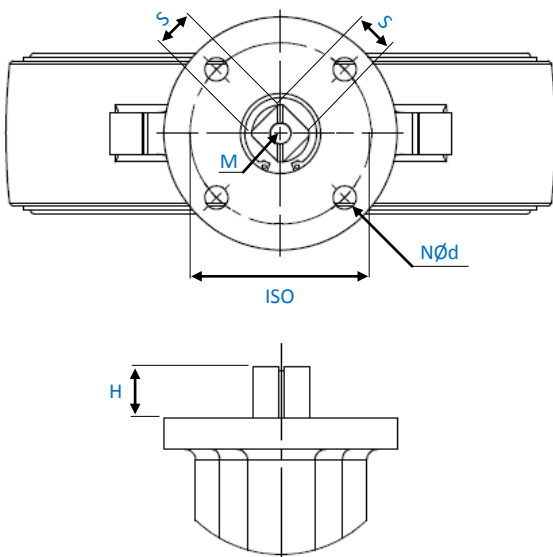

DIMENSIONS—BARE SHAFT						
Size MM	ISO	S	H	M	NØd	
					No. Holes	Hole Dia.
50	F07 (70mm)	11	15	M6	4	9
65	F07 (70mm)	11	15	M6	4	9
80	F07 (70mm)	11	15	M6	4	9
100	F07 (70mm)	14	20	M8	4	9
125	F07 (70mm)	14	20	M8	4	9
150	F07 (70mm)	17	20	M8	4	9
200	F10 (102mm)	17	25	M8	4	11
250	F10 (102mm)	22	25	M8	4	11
300	F10 (102mm)	22	25	M8	4	11

RESILIENT SEAT BUTTERFLY VALVE

WAFER DN50 - DN300

MODEL: BFW



TECHNICAL DATA

CV VALUES

Cv is defined as the volume of water in U.S.G.P.M that will flow through a given restriction or valve opening with a pressure drop of one (1) p.s.i at room temperature. Recommended control angles are between 25° - 70° open.

Preferred angle for control valve sizing is 60° - 65° open. To convert Cv to Kv divide by 1.1553.

TORQUE DATA

Torque is the measure of the turning force on an object. For a butterfly valve the turning force is determined by the friction of the disc and the seat, bushing friction and fluid dynamic torque.

OPTIONS

- Actuators
 - Electric
 - Pneumatic
 - Hydraulic
- Extensions
- Lockable Gearbox
- Chain wheel Operation
- Limit Switches

Open° vs Size	Cv VALUES								
	50	65	80	100	125	150	200	250	300
5°	0	0	0	0	0	0	0	0	0
10°	0	0	0	0	0	4.3	21	15	27.3
15°	0	2.47	0.86	2.27	5.42	21.8	66	62	153
20°	1.5	8.9	5.39	14.1	24.2	53	111	112	247
25°	5	18	14.7	30.7	48.7	92.3	167	252	373
30°	9.95	21.6	27.4	43.2	76.7	134	238	363	535
35°	16.5	24.2	43.4	69.5	112	183	326	503	739
40°	24.6	24.3	45.5	96.7	178	244	434	674	988
45°	28.1	39.5	64.2	130	206	320	571	888	1301
50°	34.9	46.6	88	173	273	420	751	1171	1720
55°	38.1	50	119	230	361	548	986	1540	2294
60°	51.8	72	163	313	479	719	1316	2031	3006
65°	68	104	212	412	629	936	1718	2708	3950
70°	86	137	275	551	835	1227	2261	3588	5524
75°	104	179	411	650	1089	1575	2987	4826	7086
80°	124	227	439	807	1340	1948	3717	6233	8870
85°	139	265	513	869	1376	2006	4058	7178	10122
90°	150	300	555	940	1482	2175	4374	7739	11650

Size	TORQUE VALUES (Nm)								
	50	65	80	100	125	150	200	250	300
16 BAR	18	33	42	58	77	154	221	350	850
10 BAR	14	22	31	44	58	124	178	320	520
6 BAR	12	17	25	39	51	99	164	240	420
3 BAR	9	14	21	33	46	85	118	122	360
No Pressure	7	10	17	28	40	54	95	124	210

*TORQUE NOTES:

Results provided are differential pressure conditions with clean municipal water.

- These figures do not include and safety factors.

For conditions that vary from those noted, apply the following Application Factor Multipliers:

- Operated less than once per day x 1.2

- Dry Service with gas or air x 1.5

- Dry Service with abrasive powder x 1.7

- Lubricant oils x 0.5

- Temperature - lower than -4.5°C x 1.2

- higher than 93°C x 1.2

- For NBR (Nitrile) Seat Figures will be 1.1 times

- Chemical attack: **Consult Challenger**

HOW TO ORDER								
Series	Design	Seat	Disc & Stem	Connection	Rating	Size	Actuator	Accessories
BF	W	E	E	S	4	0100	H	
Example: DN100 BF Wafer Butterfly Valve, EPDM Seat, SS Trim, Wafer Style, PN16 with Lever Handle								
Series				Rating			Extra	
BF = AS4795.1 Certified Seal on Body Butterfly Valve				1 = PN3*	2 = PN6*	3 = PN10*	4 = PN16	Left Blank = No Extra
Design				Size		CH = Chain Wheel (Chain Drop to be specified)		
L = Lugged Construction				0050 = 2" (50mm)	0100 = 4" (100mm)	0200 = 8" (200mm)	I = Input Stop Box	
W = Wafer Construction				0065 = 2 1/2" (65mm)	0125 = 5" (125mm)	0250 = 10" (250mm)	T = Torque Limiter	
Seat				0080 = 3" (80mm)	0150 = 6" (150mm)	0300 = 12" (300mm)	L = Lockout Device	
E = EPDM				Actuator			D = Dial Position Indicator	
N = Nitrile (NBR)*				BS = ISO Bare Shaft			B = Buried Service	
V = Viton*				H = Lever Handle DI (Standard)			X = Other (Must specify)	
Disc & Stem				W = Worm Gearbox (Standard—Clock Close Only)			Note:	
E = CF8M Stainless Steel Disc & 431 Stainless Steel Stem				WSA = SAMBO Gearbox (Anti Clockwise Close)			To include electric or pneumatic actuators, please specify the required part number as per the size chart on page 3 or visiting the relevant data sheet.	
Connection				WSC = SAMBO Gearbox (Clockwise Close)				
S = AS2129 Table E/D & ANSI #150 (Wafer Only)				WD = Dec clutch able Gearbox				
E = AS2129 Table E				K = Key Cap			For valve extension spindles, please specify the required part number as per the code builder on the relevant data sheet.	
D = AS2129 Table D				X = Other (Must Specify)				
A = ANSI #150							Visit the Challenger website to access further data sheets.	

* Denotes valve not certified to AS4795.1 with these options.