



Stainless Steel Pumps

Model 3M & 3M4 304 S/S Centrifugal Pumps (2 pole & 4 pole)

To DIN 24255



These stainless steel pumps feature a unique one piece volute casing that is produced using an advanced computer controlled Plasma stamping system that ensures total quality control during manufacture. With the smooth surfaces of stamped stainless steel, this results in consistent high standard products, of superior quality and high efficiency.

The back pull-out construction permits the disassembly and overhaul of the impeller, mechanical seal and motor without removal of the suction or discharge piping, or pump casing.

The centre line discharge and foot support under the casing ensure maximum resistance to misalignment and distortion from pipe loads.

All the hydraulic and wetted components are manufactured in 304 Stainless Steel



Economical extended motor shaft design.

Specifications

- End suction centrifugal pump with closed impeller
- Maximum working pressure: 10 bar
- Liquid temperature: -10 °C to +90 °C (standard construction)

Materials

- Pump casing: 304 Stainless Steel
- Impeller: 304 Stainless Steel
- Casing cover: 304 Stainless Steel
- Shaft: 304 Stainless Steel (wetted part)
- Motor bracket: Cast Iron
- Mechanical seal: Carbon/Ceramic/NBR

Motor Data

- Extended shaft motors, aluminium frame
- TEFC, 2 or 4 pole, 50 Hz
- Insulation class F
- IP55 Protection
- 3 Phase (dual voltage motors)
- 400/690 V (5.5 kW & above) 230/400 V (up to 4.0 kW)

Range

- 32 to 50 mm Ø discharge
- 1.1 to 15 kW - 3 Phase (2 pole models)
- 0.37 to 2.2 kW - 3 Phase (4 pole models)

Options

- High temperature seal (110 °C)
(Carbon/Ceramic/Viton seal, Viton O' Rings)
- Hard faced seal (110 °C)
(SiC/SiC/Viton seal, Viton O' Rings)

Accessories

- Carbon steel or 304 stainless steel companion flange kits available

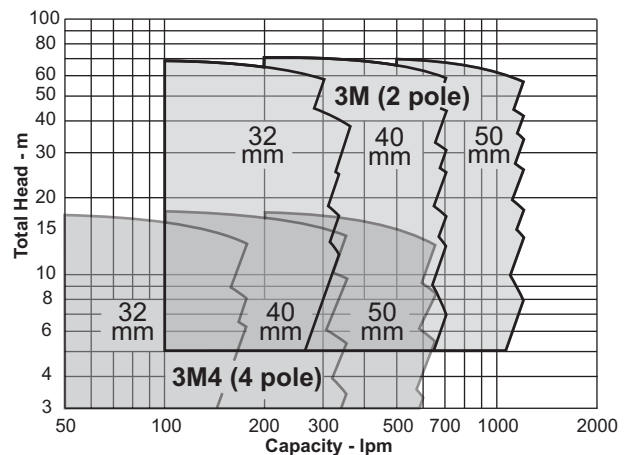

Model Code

3M 40 - 200 / 7.5
 Motor Size kW
 Nominal Impeller Diameter mm
 Discharge Size Ø mm
 3M = 2 pole model, 3M4 = 4 pole model

- 2 Pole & 4 pole versions
- Over 30 models
- 32 mm to 50 mm discharge size
- 0.37 to 15 kW motor power
- Flows to 1200 lpm
- Heads to 70 m

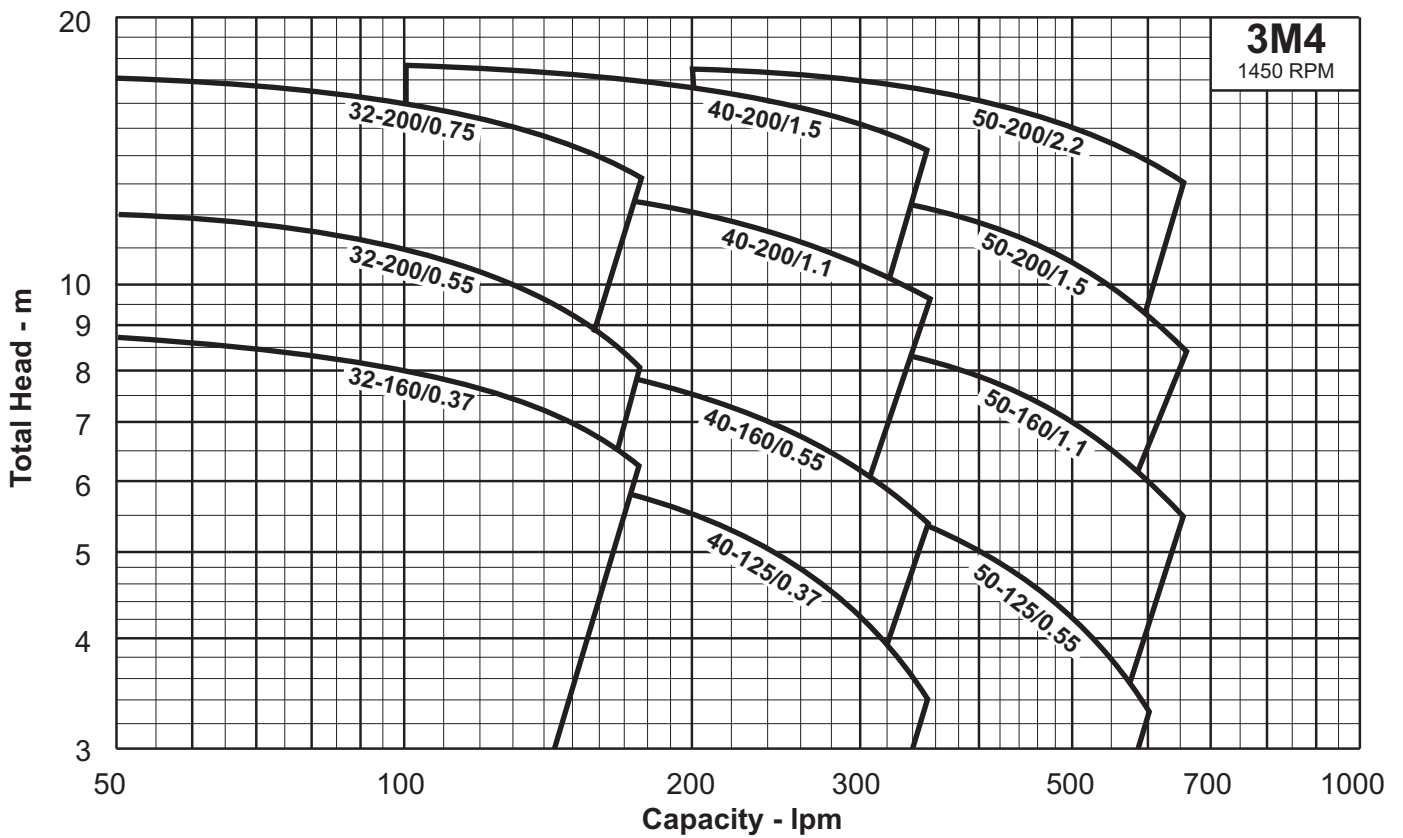
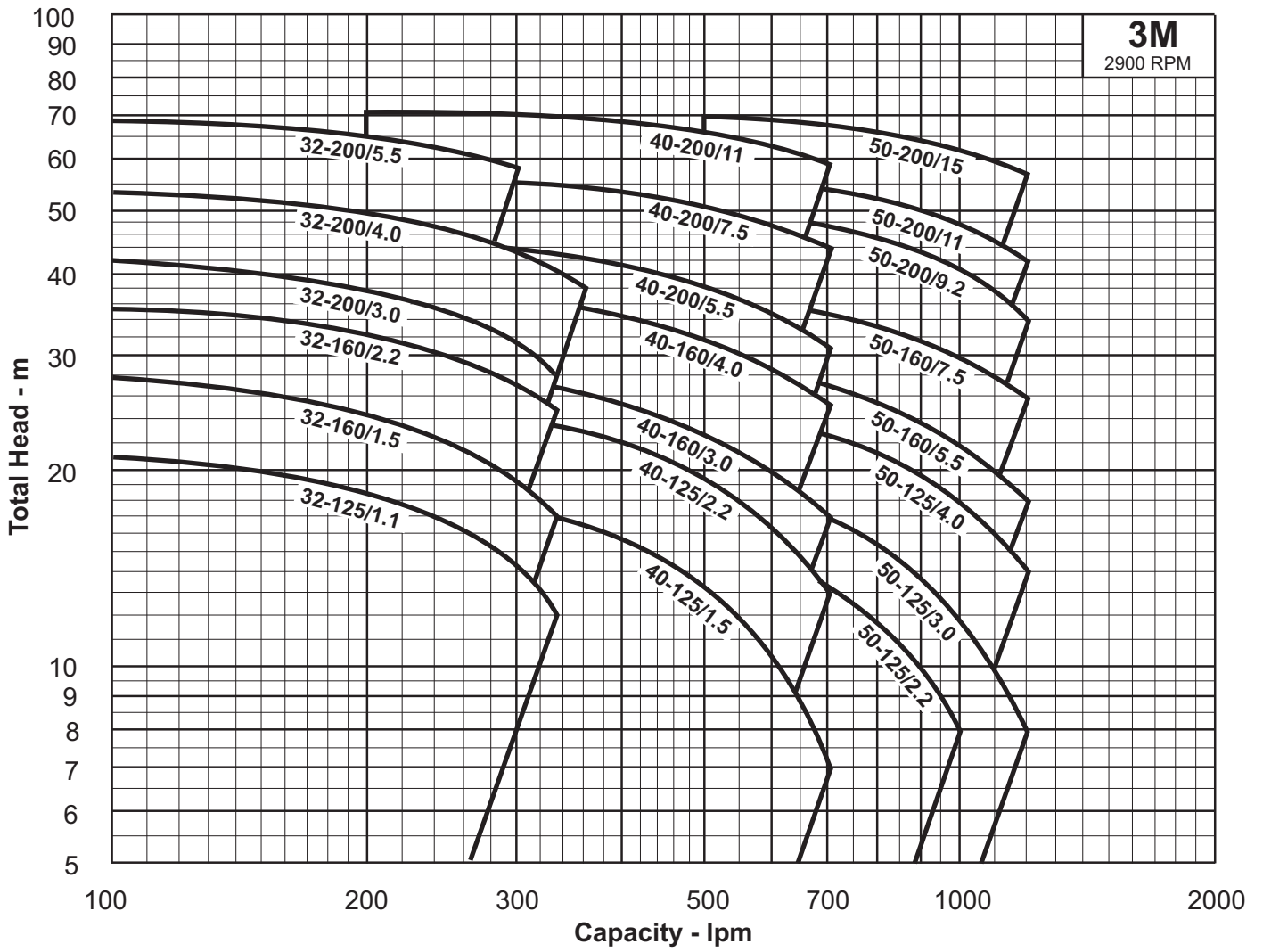

Dimensions

Model **3M & 3M4**

Units: mm unless otherwise specified

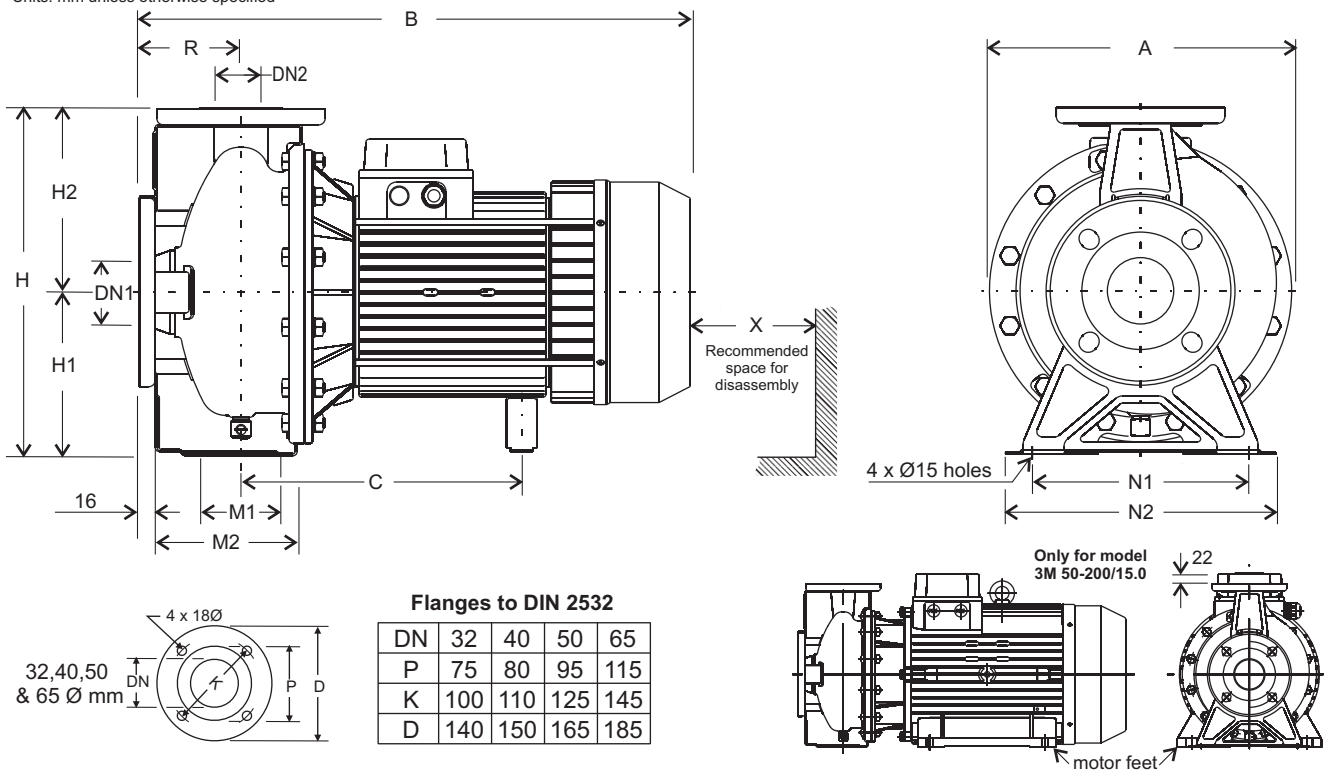

Flanges to DIN 2532

DN	32	40	50	65
P	75	80	95	115
K	100	110	125	145
D	140	150	165	185

FLC = Full Load Current

DN2 x DN1	2 Pole Pump Model	FLC 3 Phase 400 V	Dimensions											Weight (kg)	
			A	B	C	R	H1	H2	H	M1	M2	N1	N2		X
32 mm x 50 mm	3M 32-125/1.1	3.2 A	213	407	231	80	112	140	252	70	114	140	190	110	24
	3M 32-160/1.5	3.2 A	254	407	231	80	132	160	292	70	118	190	240	110	27
	3M 32-160/2.2	4.5 A	254	432	231	80	132	160	292	70	118	190	240	110	28
	3M 32-200/3.0	6.1 A	296	471	256	80	160	180	340	70	119	190	240	110	35
	3M 32-200/4.0	8.7 A	296	494	256	80	160	180	340	70	119	190	240	110	38
	3M 32-200/5.5	10.4 A	296	519	276	80	160	180	340	70	119	190	240	110	52
40 mm x 65 mm	3M 40-125/1.5	3.2 A	213	407	231	80	112	140	252	70	114	160	210	115	25
	3M 40-125/2.2	4.5 A	213	432	231	80	112	140	252	70	114	160	210	115	26
	3M 40-160/3.0	6.1 A	254	471	255	80	132	160	292	70	118	190	240	115	37
	3M 40-160/4.0	8.7 A	254	494	255	80	132	160	292	70	118	190	240	115	41
	3M 40-200/5.5	10.4 A	296	539	278	100	160	180	340	70	115	212	265	115	53
	3M 40-200/7.5	13.7 A	296	539	224	100	160	180	340	70	115	212	265	115	56
50 mm x 65 mm	3M 40-200/11.0	21.9 A	296	595	224	100	160	180	340	70	115	212	265	115	67
	3M 50-125/2.2	4.5 A	254	452	231	100	132	160	292	70	114	190	240	125	32
	3M 50-125/3.0	6.1 A	254	491	255	100	132	160	292	70	114	190	240	125	35
	3M 50-125/4.0	8.7 A	254	514	255	100	132	160	292	70	114	190	240	125	41
	3M 50-160/5.5	10.4 A	296	539	278	100	160	180	340	70	115	212	265	125	47
	3M 50-160/7.5	13.7 A	296	539	224	100	160	180	340	70	115	212	265	125	56
	3M 50-200/9.2	16.8 A	296	595	239	100	160	200	360	70	115	212	265	125	64
3M 50-200/11.0	21.9 A	296	595	239	100	160	200	360	70	115	212	265	125	67	
3M 50-200/15.0	28.3 A	314	723	N/A	100	160	200	360	70	115	212	265	125	102	

FLC = Full Load Current

DN2 x DN1	4 Pole Pump Model	FLC 3 Phase 400 V	Dimensions											Weight (kg)	
			A	B	C	R	H1	H2	H	M1	M2	N1	N2		X
32 mm x 50 mm	3M4 32-160/0.37	1.1 A	254	393	219	80	132	160	292	70	118	190	240	110	20
	3M4 32-200/0.55	1.5 A	296	393	219	80	160	180	340	70	119	190	240	110	25
	3M4 32-200/0.75	2.7 A	296	432	230	80	160	180	340	70	119	190	240	110	28
40 mm x 65 mm	3M4 40-125/0.37	1.1 A	213	371	205	80	112	140	252	70	114	160	210	115	16
	3M4 40-160/0.55	1.5 A	254	393	219	80	132	160	292	70	118	190	240	115	21
	3M4 40-200/1.1	2.7 A	296	452	230	100	160	180	340	70	115	212	265	115	29
	3M4 40-200/1.5	3.6 A	296	491	230	100	160	180	340	70	115	212	265	115	31
50 mm x 65 mm	3M4 50-125/0.55	1.5 A	254	413	219	100	132	160	292	70	114	190	240	125	21
	3M4 50-160/1.1	2.7 A	296	452	230	100	160	180	340	70	115	212	265	125	29
	3M4 50-200/1.5	3.6 A	296	491	230	100	160	200	360	70	115	212	265	125	32
	3M4 50-200/2.2	4.7 A	296	474	253	100	160	200	360	70	115	212	265	125	36

Specifications subject to change without notice

Typical construction

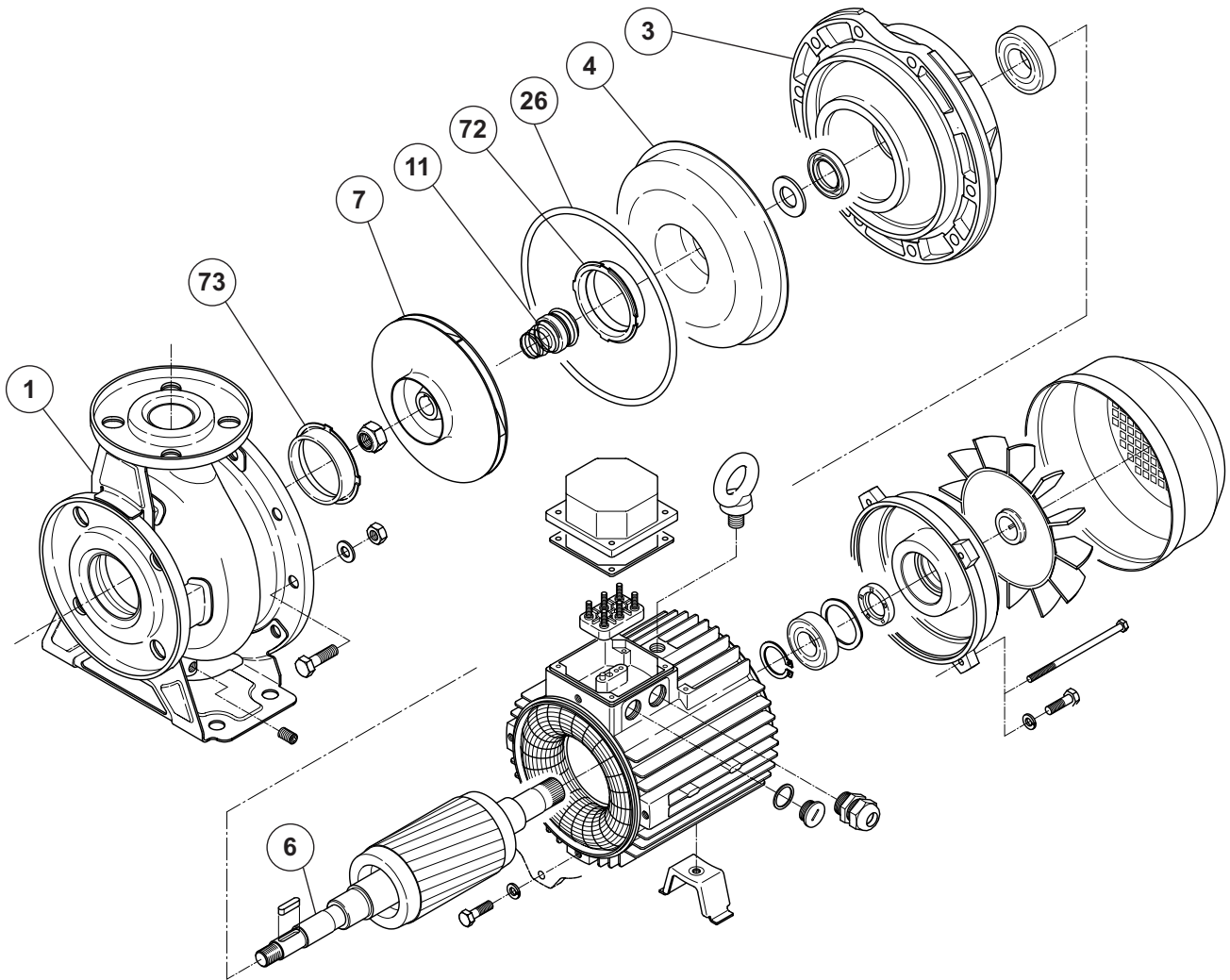

Item	Description	Suits models	Materials
1	Casing	All 32, 40 & 50 models	304 Stainless Steel - stamped
3	Motor bracket	All models	Cast Iron
4	Casing cover	All 32, 40 & 50 models	304 Stainless Steel - stamped
6	Shaft (& rotor)	All models <small>(Material refers to part in contact with liquid)</small>	304 Stainless Steel
7	Impeller	All 32, 40 & 50 models	304 Stainless Steel - stamped
11	Mechanical seal	All models	Carbon/Ceramic/NBR <small>Carbon/Ceramic/Viton - High Temp. Option SiC/SiC/Viton - Hard Face Option</small>
26	O-Ring (casing)	All models	NBR <small>Viton - when optional seals fitted</small>
72	Casing ring (rear)	32-200, 40-200, 50-125, 160, 200	304 Stainless Steel - stamped
73	Casing ring (front)	All models	304 Stainless Steel - stamped

Casing



Stamped

Impeller



Stamped

Casing Cover



Stamped

Specifications subject to change without notice