

Troubleshooting (Continued)

- **Smoke entering the room from the firebox when the door is open may be caused by**
 - Insufficient length of flue (Flue to be 4500mm minimum underneath the base of heater to underside of cowl)
 - Increase height of flue*
 - Flue downdraught
 - Consult dealer or increase height of flue.*
 - Creosote buildup in flue
 - Remove cowl and clean flue as per cleaning instructions. Check moisture content of wood.*

- **Excessive ash build up**

Some woods will give large amounts of ash despite how you run the heater. Others will give you very little. Use the wood which is most convenient for you as long as it is dry. After a period of time you will get to know when to empty your unit. Bark will give you excessive ash. Try not to burn it. If you are burning wood that gives you charcoal, you may find that after running the heater say for 8 hours at maximum burn rate, the charcoal builds up excessively. Overnight burn will reduce this charcoal back to a fine ash. If you are not ready to shut down for overnight burn when you next fuel the stove, load the stove with only one piece of wood and lay it across the firebox on top of the charcoal. Open the air control wide open and you will find the charcoal will burn down with the one piece of wood. Repeat the process until the ash level is significantly reduced.

WARRANTY

1. Subject to clauses 2 & 3 of this Warranty, A.F. Gason Pty Ltd ACN 004 667 556 (Gason warrants the follow components of its heaters against defects in workmanship and/or materials for the following periods from the date of purchase:
 - a) the firebox for ten years;
 - b) the paint finish for a period of twelve months if the Purchaser has followed the instructions provided by Gason in the Operation and Installation Instructions manual; and
 - c) all other components for twelve months except the glass, fire brick lining or baffle plate if, in the opinion of Gason, these items have been damaged by impact.
2. This extended warranty does not apply:
 - a) if the heater is purchased from a person who has not been authorised by Gason to sell its products;
 - b) if, in the opinion of Gason, the heater or any other component has been subject to abuse, misuse, alteration, modification or has not been installed, operated or maintained in accordance with the instructions provided by Gason; or,
 - c) to owners other than the original Purchaser.
3. If you believe that the heater you purchased contains a manufacturing defect and you wish to make a claim under this Warranty, please contact an authorised Gason service centre to arrange for an assessment.
4. If, after assessing the heater, Gason determines that the heater contains a manufacturing fault, Gason may at its discretion:
 - a) replace the heater;
 - b) repair or replace specific components of the heater; or
 - c) provide a full refund.
5. Parts replaced under warranty are warranted for the balance of their original warranty period.
6. If, at the discretion of Gason, the heater or any part needs to be replaced, serviced or repaired at an authorised Gason service centre, then the person claiming under this Warranty must pay all costs associated with:
 - a) returning the heater; and
 - b) the delivery or collection of any new or repaired heater.

Our goods come with guarantees that cannot be excluded under the Australian Consumer Law. You are entitled to a replacement or refund for a major failure and for compensation for any other reasonably foreseeable loss or damage. You are also entitled to have the goods repaired or replaced if the goods fail to be of acceptable quality and the failure does not amount to a major failure.

Any benefits you receive under these warranties are in addition to other rights and remedies that you may have as a consumer under a law in relation to the heater to which these warranties relate.

These warranties are given by:

A.F. Gason Pty. Ltd.
 Blake Street
 Ararat VIC 3377
 Please contact us if you have any queries on:
 Phone: 03 53522151
 or email us via the "Contact Us" section of our website: www.gason.com.au



Riverina SRS3 Insert

Operation & Installation Instructions

Rev A

Please keep these instructions for future reference.

231312

**WARNING**

Read and follow these instructions carefully before installing and using this appliance

SAVE THESE INSTRUCTIONS

**WARNING**

Safety Warnings

- A flue fire with resulting damage may occur if the appliance is not installed, operated and maintained as per this booklet.
- Never place combustible materials such as wood, paper or furniture near the appliance.
- This appliance is designed to burn dry wood. Do not burn rubbish, driftwood, flammable liquids or any substance containing salts or corrosives.
- This appliance must not be installed and operated in an area where kerosene, petrol, paint thinner or other flammable liquid is used or stored.
- The flue system must be inspected and cleaned annually or sooner if required. Failure to do so could result in an excessive buildup of creosote which may result in a flue fire which may damage the flue or cause damage to your home.
- The surface of the appliance becomes hot during operation. Do not touch the surface of this appliance. Keep children away from this appliance during operation. Do not allow anyone to operate this appliance who is not familiar with this instruction booklet.

**WARNING**

Paint curing and care

Your heater is coated with the best available heat resistant paint. Even though the paint has been baked after application, it may require further temperature curing. It may, if you overfire the heater on its first fire, discolour. For your first two or three firings, never exceed medium air setting and always have the fan on when above low burn. Do not wipe the heater while the paint is curing. After the paint has cured the only maintenance required to maintain the heaters finish is to wipe it with a soft cloth. Do not use any commercial cleaners or solvents on the paint finish.

We are proud of the presentation of our products. If at any time you need to freshen up the paint, your local dealer has touchup paint available for purchase. You may even change the colour of your heater if you wish.

If you have any enquiries, please contact the dealer from whom you purchased your heater:

PLEASE COMPLETE:

Dealer Name _____

Dealer Address _____

Phone: _____

Please attach your original purchase dockets to this booklet for future reference.

Troubleshooting

• **Noisy Fan**

Turn the power off and remove the three pin plug from the power point. Remove the four screws that hold the front fan access panel. Remove the panel. Disconnect the wiring loom via the plastic joiner. Unscrew the nut which holds the fan in position and remove the fan. Clean any dust with a dry paint brush and vacuum the fan blades. Clean around the motor. After completion place two or three drops of sewing machine oil on the shafts at the bearings. Replace the fan in reverse to the removal.

• **Fan not working**

Check the power connection with another appliance. If the power point is O.K. assume the Fan or the Switch is defective. Isolate the power as above. Check that the terminals on the loom and the switch are firmly connected. If the fan then fails to function, remove the fan and switch by firstly removing the knob off the fan switch by pulling it away from the heater. Undo the holding nut and pull the switch out. Disconnect the wiring from the power lead and remove the fan and switch. Convey the same to the authorised Eureka Dealer from whom you purchased your unit for service. Replace in the reverse order.

• **Air Control Jamming**

Lift up and remove top plate.

Remove air control knob by turning anti-clockwise. Lift air control panel out of the way.

There are three bolts holding the air slide in place. Undo them and remove the air slide. Wipe any ash or dust that may have accumulated on the back of the air slide or on the face of the heater. If any burrs have developed on the back of the air slide or on the face of the heater, rub them off with fine wet and dry sand paper till you have a smooth surface and edges. Replace the air slide and make sure the washers and spacers are on the bolts when you screw the bolts back into the face of the heater. Do not apply any type of lubricant to the air slide whatsoever as this will attract dust and make the slide stick.

• **No Overnight Burn**

Remove the air slide as per air control jamming and check that the air slide is hard against the face of the heater. If it is loose, tighten up the bolts holding the air slide to the face of the heater. Do not overtighten.

Check that the door rope has an even indentation from the sealing strip, which is on the face of the firebox. If it is uneven and it appears as though air could leak through the seal, adjust the thickness of the door rope to suit. Stretch the rope to make it thinner where the indentation is the heaviest and bunch up the excess where the indentation is smaller.

Check the four bolts that hold the glass retainer in position. If loose tighten. Do not overtighten.

The door may become loose through the door seal shrinking. To tighten the door, open the door and look at the inside of the door shaft. Unscrew Allen key screw in door handle shaft. Rotate door handle shaft anti-clockwise when facing heater (1 turn = 1 millimetre). Close door and lock. Open door and check door for even indentation from sealing strip. Repeat process if required. Replace Allen key screw (check to ensure that roll pin is central in shaft.)

When closing the door you should now feel firm resistance when the latch comes into contact with the catch.

**WARNING****Overfiring**

NEVER OPERATE THE HEATER WITH THE DOOR LOOSE AND DO NOT AIR TIGHT OVERFIRING COULD RESULT IN DETRIMENTAL WEAR AND TEAR ON THE FIREBOX.

Troubleshooting (Continued)

Overnight burn

Approximately 30 minutes before turning the heater down to overnight burn it is recommended to load the heater with fuel for the overnight burn. Leave the air control in the medium to high position. Let the heater run for about thirty minutes. This will reduce the moisture content in the fuel before shut down. (This will help reduce the creosote formation in the firebox and flue.) Set the air control to the setting you have found best for your requirements. Turn the fan off and retire. The aim when overnight burning is to have only a few hot embers left in the bottom of the firebox in the morning. Not huge lumps of wood.

Cleaning your flue

Carefully remove baffle plate and put it to one side. Close the heater door. Obtain a 150mm flue brush from your local Jindara Dealer and proceed up onto your roof. Remove the cowl. Slowly push the flue brush down the chimney until it stops. Pull the brush back out and repeat the process. Each time you do this you will notice that the brush will go further down the chimney till it reaches the bottom. The soot and creosote will fall down the chimney and into the firebox. Clean residue from firebox. Replace the baffle plate. Make sure you do the job well. The cleaner the flue the less chance there will be of the creosote sticking again. After you have replaced the cowl, inspect the roof flashing for any damage that may have been incurred whilst you were cleaning the flue. Reseal the seal on the roof with roof and gutter silicone if required.

The fan

It is recommended to run the fan while the heater is operating above low burn on low speed. For extended periods when the heater is running above medium fire, high or boost is recommended. Boost is recommended for short bursts where a quick temperature rise is desired in conjunction with a high fire setting. The fan should be cleaned on a regular basis. (Refer Troubleshooting for fan removal and cleaning.)



If firebox failure is reported and it is found that the firebox has been abused through improper use of the fan, Jindara reserve the right to disallow any warranty claims in relation to firebox failure.



Leaving Door Open

As stated previously in relation to leaving door open 25mm to encourage the fire to pick up at a faster rate. Your heater has been tested to ensure that no structural damage can take place if the door is inadvertently left open. However your paint finish can be damaged if the door is left open for a long period with a full firebox of fuel with the fan off. Closely supervise your heater while the door is left open.

Closing the Door

Always ensure that before you close your door there is no wood protruding beyond the front of the firebox opening. Do not use the door glass as a 'battering ram' to push the wood back into the firebox. Damage to the glass by such impact is not covered by your warranty.

Installation



This heater is to be installed into a masonry fireplace or a Jindara ZCV Clearance cabinet.

THE INSTALLATION OF THIS APPLIANCE MUST BE CARRIED OUT AS PER THIS MANUAL AND THE FLUE MANUFACTURERS SPECIFICATIONS.

WE RECOMMEND THAT YOU USE A QUALIFIED INSTALLER TO CARRY OUT THE INSTALLATION.

If you have any other enquiries, please contact the dealer from whom you purchased your heater.

THIS APPLIANCE WEIGHS IN EXCESS OF 120 KILOGRAMS. EXTREME CARE SHOULD BE TAKEN WHEN HANDLING THE APPLIANCE.

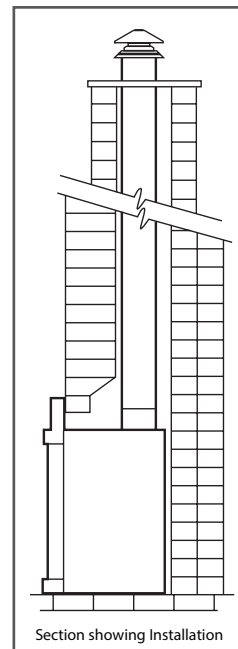

Figure 1. Masonry Installation

All dimensions used in this document are in millimeters and are minimum unless otherwise stated. Under no circumstances can these dimensions be reduced.

AF Gason Pty Ltd accepts no liability whatsoever for any interpretation of AS/NZS 2918:2001

Installation Permit

Depending on your local authority requirements, a permit may be required for the installation of your heater. It is your responsibility to arrange the same.

Installation into existing or masonry fireplace

The Jindara Riverina Insert can be installed into a masonry fireplace with a flue system that is in accordance with the relevant sections of AS/NZS 2198:2001. No combustible or heat sensitive material may be placed closer than 1040mm from the top of the hearth/base of appliance and 50mm either side of the appliance's fascia.

Minimum hearth depth of 530mm from the front of the fascia panel must be achieved. If it is desired to reduce the hearth depth to the minimum allowable 300mm in front of appliance fascia, the appliance must be raised to a new height - refer elevated installation instructions on page 7.

For detailed mantle clearance dimensions, refer Figure 4.



IF BRICKS REQUIRE REMOVAL WHEN PREPARING THE FIREPLACE, ENSURE THAT YOU DO NOT EXPOSE COMBUSTIBLE MATERIALS BEHIND THE BRICKWORK OR WEAKEN THE INTEGRAL STRUCTURE OF THE CHIMNEY.

Installation (Continued)

Clearance to combustibles & Gason Zero Clearance Box (ZCB) installation

The Jindara Riverina Insert conforms to AS/NZS 2198:2001 Appendix B, when the appliance is placed in relation to combustible surfaces, as per test report number HCMG/13/030.

The Gason Zero Clearance Box is an approved cabinet that allows certain Jindara & Eureka Insert woodheaters, in conjunction with a triple skin flue system to be installed within a non-masonry fireplace in accordance with AS/NZS 2918:2001.

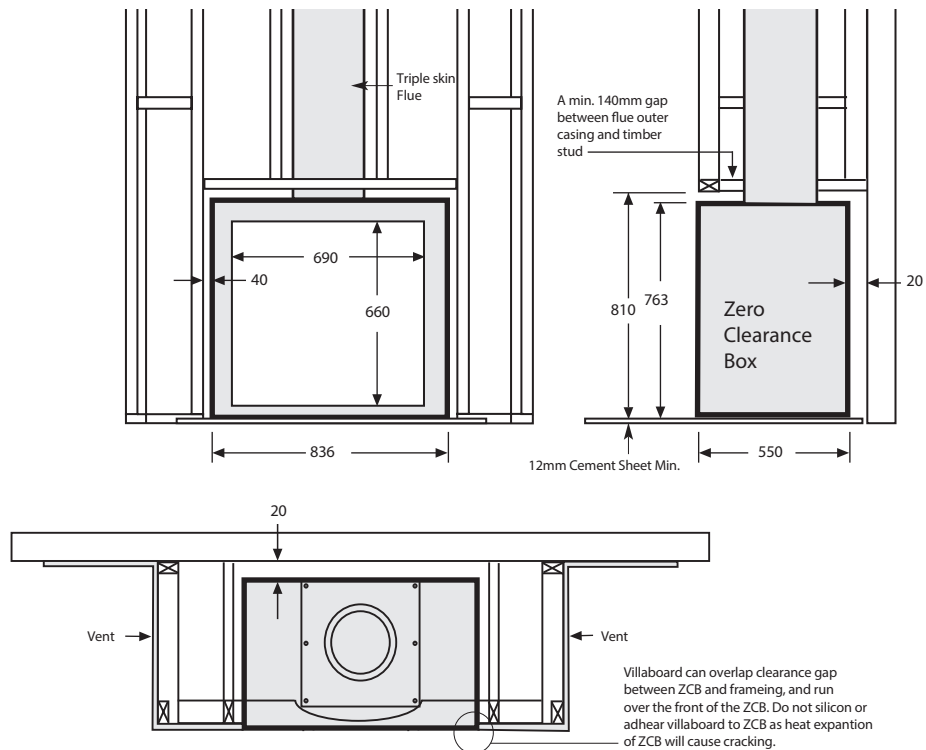

Figure 2. ZCB Installation detail

Operating your Jindara



DO NOT ATTEMPT TO OPERATE THIS APPLIANCE WITHOUT READING AND UNDERSTANDING THESE OPERATING INSTRUCTIONS THOROUGHLY. FAILURE TO OPERATE THIS APPLIANCE PROPERLY MAY CAUSE UNDUE DAMAGE TO THE APPLIANCE OR RESULT IN A FLUE FIRE.

Starting your fire

Place a firelighter or paper in the bottom of the firebox and place a large amount of small kindling on top. Ignite the paper or the firelighter. Set the air control to high and leave the main door open approximately 25mm. When the kindling is burning, place about four pieces of small wood on top of the burning kindling. Once the wood is alight, close the main door. After approximately 20 minutes, turn the air control down to medium and, turn the fan on to low speed.

On the initial fire up you may detect smoke coming from the paint finish and from any oils that may be on the steel on the outside of the firebox. This is normal. It is suggested to well ventilate your home on the initial fire up. Please refer to our section 'Paint curing and cure'.

The glass door

Always operate your heater with the door closed and locked. The only time you can leave the door open is on initial lighting, or when reloading the heater.

Care of your glass

If you are burning good dry wood, you will have very little discolouration of your glass in normal burning cycle. If you aim for an eight to ten hour overnight burn, you should not get much discolouration. You can control this by adjusting the air control, moving from the left and slowly creeping the control to the right. After a number of days you will find the right position to suit your requirements and the fuel that you are using.

Cleaning the glass

Generally the only time you will possibly need to clean your glass is after a long overnight burn. If you find that you have a wet sticky black film on your glass (creosote), it is better to burn the heater as normal for one load of wood. When the wood has burnt down to a hot bed of embers, open the door and leave it wide open until the glass cools sufficiently to be wiped with a damp cloth. This should clean all the white smoky film off the glass. Creosote on the glass is normally a sign that you have tried to get too long an overnight burn or you have burnt excessively wet or green wood. If the film on the glass won't come off with a wet cloth, you can use wet ash from the ash bed as a cleaner or commercial products such as Crystal Clear, Johnson Foam Clean or Windex.

Normal Operations

When you get up in the morning, open up the air control of the heater to high position to start the embers glowing. Place three or four pieces of wood on top of the embers and leave the door open 25mm. Once the fuel starts to flame close the door. As the heater starts to heat up turn the fan on to low, (approx 20 minutes) and begin reducing the air control towards a lower setting.

You will find with the fan on low you will only need to run the heater between low and medium to maintain the temperature you desire in your home. To obtain the maximum heat dissipation from the heater it is necessary to run the fan at any time the heater is running above the low position.

For best results it is best to burn 235mm long wood and load your wood straight into the firebox front to rear. This will give optimum efficiency and recoverable heat, and minimise creosote formation and smoke emissions.

Installation (Continued)

Placement of firebricks in firebox

Take the firebricks out of the heater. They are to be placed so that they stand on end against the rear and two side walls of the firebox. You will notice that the bricks have a bevel on one end.

Inside the firebox there is a "C" shaped angle iron firebrick retaining bracket. This is designed to sit over the bricks and hold them in place. This should be placed in the firebox so that you see a flat face of the angle iron on both sides of the firebox and at the rear of the firebox.

Holding the "C" frame up to the top of the firebox, insert a whole firebrick, standing it vertically with the bevel edge pointing down and facing inwards toward the left hand side of the firebox. Lower the left hand side of the "C" frame onto the firebrick. Repeat with a whole firebrick on the right hand side.

Place firebricks (3 whole firebricks) using the same method against the back wall of the firebox.

Now place one extra whole firebrick on either side of the firebox to complete the installation of the firebricks. (i.e. two each side and remainder on the back wall.)

Push each brick and "C" frame firmly against the wall of the firebox and you are ready to light your fire.

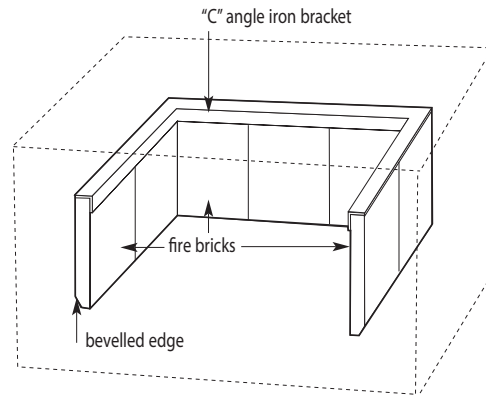
**Fitting the Baffle Plate**

1. Feed baffle plate through the door opening with front edge folded up all the way to the rear of the heater.
2. Lift front over Pin A and slide towards front of heater.
3. Lift rear so baffle plate is horizontal and move towards back of heater.
4. Lower over Pin B.
5. Baffle plate must be sitting on Pins A & B.

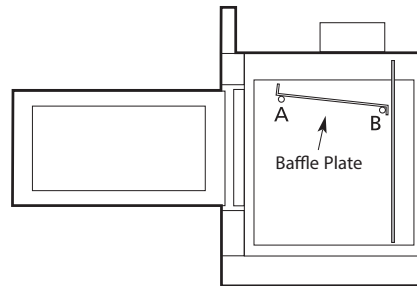
**Final inspection prior to use**

- Ensure the baffle is firmly located.
- Ensure firebrick liners – sides and back are positioned correctly.
- Check fan cord has not been damaged during transit.
- Plug in fan cord and ensure cord does not touch stove surface.
- Check all door seals are fitting correctly.

Installation (Continued)

ZCB installation notes

- Select the position that you wish to install your ZCB, carefully allowing for flue clearances of 305mm in the roof cavity (the outer flue being 255mm requires a 25mm clearance on either side to combustibles, making overall clearance of 305mm).
- Place hearth (cement fibre sheet) under the position desired for the zero box. Place the zero box into position.
- Fit flue upstands to zero box.
- Fit flue to the upstands and terminate at the required height above the roof line.
- Fit 300mm x 100mm vermin proof vent directly behind where the zero box will be located, as near as practicable to the floor. This vent will allow air access to the zero box either from another room or external air. Note: If installed on a timber floor, an additional two vents are required. i.e. either through the floor, one each side of the ZCB, or alternatively, through the side wall(s) if applicable.
- Build your frame around the ZCB maintaining the clearances listed above.
- Cover the front with a 4mm cement sheet or non-combustible material for the first 300mm above the appliance.
- Insert your chosen appliance in the zero box and fit the active flue and cowl.
- Install the mantel if required. Note: If mantel is made out of combustible material the following dimensions must be adhered to.

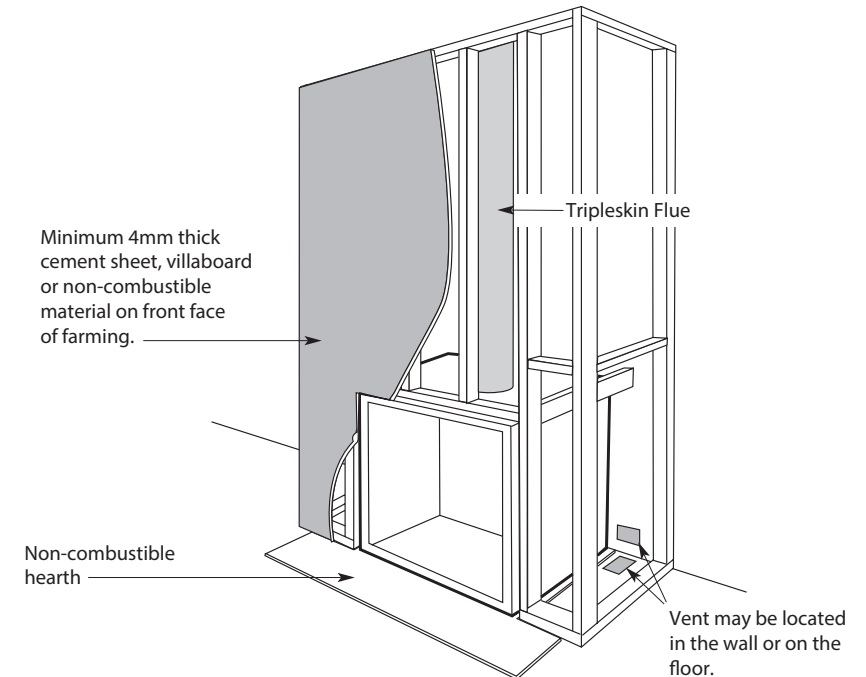

Figure 3. ZCB Installation Step 1.

Installation (Continued)

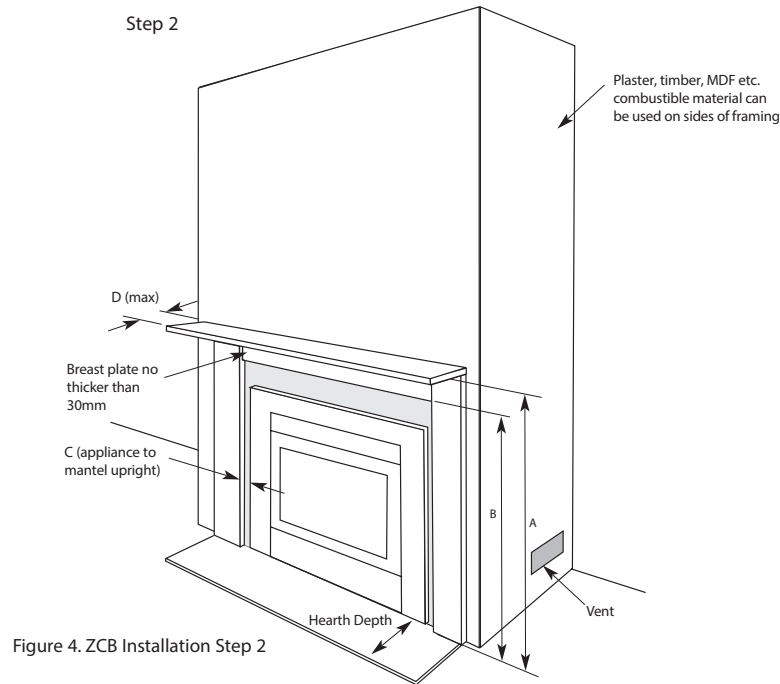

Figure 4. ZCB Installation Step 2

Mantel Clearances

A	B	C	D
1100	1040	50	250

Minimum hearth sizes

Depth	Width	Depth Overall	Thickness
530	890	1120	12

Installation (Continued)

Elevated installation

In some instances it may be desirable or required that the Jindara Riverina Insertwoodheater be installed onto a step of an existing fireplace or mid-wall inside a Gason ZCB. In either of these situations, a step or structure must be constructed of non-combustible material and withstand the combined weight of the appliance and ZCB.

The following table represents the relationship between the height at which the appliance can be raised, and minimum required hearth depth from the front of the appliances fascia panel, to front of hearth.

i.e. if the appliance is raised by 120mm above hearth/existing floor, the hearth can reduce from 530mm to 375mm in front of the appliances fascia.

When appliance is raised 155mm or more above floor level, a 300mm non-combustible hearth or floor protector is always required as per AS/NZS 2018:2001.

If the appliance is installed onto an existing step/fireplace which projects in front of the appliance's fascia less than required (corresponding height of step/fireplace to floor), an additional hearth or floor protector will be required to extend to the minimum required hearth depth required for the step height.

i.e. An appliance is installed onto an existing step/fireplace 105mm above a wooden floor. The existing step/fireplace projects 250mm in-front of the appliance's fascia. Using Table 1, the closest minimum height related to 105mm is 103mm and its reflective hearth requirement of 400mm. For this installation to conform with AS/NZS 2918:2001, 150mm of villaboard (or similar non-combustible material) must extend in-front of step/fireplace of minimum width 890mm and thickness 12mm.

Minimum Hearth Depth	Appliance raised by
X	Y
530	0
525	5
500	30
475	50
450	70
425	87
400	103
375	118
350	132
325	144
300	155
300	≥155

Table 1. Appliance height vs hearth requirements

