

TD-2300A-X Series

WTPMS



Extended Range Series

Supports 4 to 34 Wheels



Truck & Trailer
TYREDOGTM

Wireless Tire Pressure Monitoring System

Safety
Fuel efficiency
Extends tire life

INDEX

IMPORTANT INFORMATION	3
TPMS ADVANTAGES	4
FEATURES	5
ITEM DESCRIPTIONS	8
MONITOR DESCRIPTION	8
RELAY DESCRIPTION	9
MONITOR BRACKET DESCRIPTION	9
3-WAY ADAPTER DESCRIPTION	9
SENSOR DESCRIPTION	10
GRAPHIC USER INTERFACE (GUI)	10
GETTING STARTED	11
INSTALLATION	11
INSTALLING THE RELAY	11
INSTALLING THE MONITOR	15
INSTALLING THE SENSORS	18
MONITOR SWITCH & BUTTONS	21
POWER SWITCH	21
MUTE BUTTON	22
TEMPERATURE BUTTON	22
BACKLIGHT BUTTON	23
TPMS SETTINGS MENU	24
UNIT SETTINGS	25
THRESHOLD SETTINGS	26

INDEX Continued..

TYPE OF VEHICLE (WHEEL LAYOUTS)28
ADD NEW RELAY (RESET)31
ADD NEW SENSOR33
HOW TO USE YOUR TPMS SYSTEM36
TROUBLE SHOOTING41
PACKAGE CONTENTS - MONITOR46
PACKAGE CONTENTS - RELAY47
SPECIFICATIONS49
WARRANTY INFO51

Important Information

- This product is designed to indicate the conditions of the air inside your vehicle's tyres. It should not be considered as a device that will prevent any traffic accident, injury or death.
- Tyres and valve stems must be checked before installation. It is very common for rubber valve stems to require replacement without showing signs of wear. We recommend use on Metal type Valve Stems.
- Never overload your vehicle. Overloading is extremely dangerous and can cause failure of tyres, suspension and driveline components. A vehicle should never be operated if the GVM is greater than the design specification. Even a correctly inflated tyre can fail when overloaded.
- It is the driver's responsibility to ensure safe driving conditions are met before setting off on any trip or journey.

TPMS Advantages

A Tyre Pressure Monitoring System (TPMS) is an efficient and effective solution to many current automotive safety issues. TPMS will help minimise driving risks and reduce fuel consumption. Some benefits include:

- Ensures safe driving conditions.

Tyre pressures can alter ride comfort and handling response.

- Minimises chances of tyre blowout.

Blowouts are a growing cause of road accidents. Even if a car can recover from a blowout, the damaged tyre left behind is an even greater hazard.

- Reduces time taken to inspect tyres.

It can be very time consuming to walk around large vehicles to inspect each tyre. A TPMS will help pinpoint a faulty tyre to save time. Everybody from driving enthusiasts, to small business owners, even nation-wide fleet operators can benefit from the time saved by a TPMS.

- Reduces running costs.

A properly inflated tyre ensures maximum fuel efficiency in all driving conditions. When a tyre is underinflated, it causes more rolling resistance, significantly increasing fuel consumption, engine and transmission wear.

- Extends tyre life

Tyres can be an expensive necessity especially in trucks or sports cars. An underinflated tyre wears quicker meaning it needs replacing sooner.

Exclusive Features

TYREDOG is a powerful tool for maximising uptime and improving safety. TYREDOG sets a new standard in wireless tyre pressure monitoring systems.

A leading WTPMS solution for the light to heavy-duty car and trucking industries, TYREDOG is continuously developing new and better TPMS designs and manufacturing technologies. TYREDOG has helped major players in the trucking industry improve safety and reduce operational costs. The major feature of TYREDOG TPMS is the use of the world's smallest valve cap sensor. The extremely lightweight, compact sensor has been designed to simplify installation and remove the need to have wheels balanced when fitted. Through wireless technology, tyre pressure and temperature information is displayed on the friendly Graphic User Interface (LCD monitor).

Installation

- **D.I.Y:** System can be fitted quickly without any technical knowledge.
- **Wireless:** All signals are sent via radio frequency with no wires.
- **Battery powered:** Sensors, monitor* and relay are battery powered. Monitor and relay can be operated with supplied power cables.
- **Security:** All kits include the SecureFit locking mechanism meaning your sensors will not come loose unexpectedly.
- **Relay:** Increases the signal transmission range, meaning tyres can be monitored on the largest and most complex vehicles.

* Refer to page #8.

Exclusive Features continued..

Operation

- **Real-time:** Tyre pressures are updated automatically so there is no need to push buttons to check up on your tyres (except temperature).
- **Graphical user interface (GUI):** All information is displayed together so unlike other systems, there is no need to scroll through each wheel to view status.
- **Adjustable:** High and low warning alarms can be set 'per axle.'
- **Audible:** You can't be expected to always keep watch of your tyres, so a built in alarm will sound when there is a sudden change in pressure or temperature, giving you peace of mind.

Design

- All sensors can be securely locked onto tyre valves for added safety.
- Learnable sensors are available so in the event of theft or damage, sensors can be quickly and easily replaced.
- Sensors have unique individual codes to ensure there is no interference from other 433MHz devices, even other TYREDOG systems.
- All TYREDOG kits undergo strict field testing to ensure quality.
- The TD-2300A-X can monitor tyres with pressures up to 180psi so all applications are supported.
- Sensors are treated for anti-corrosion during manufacture and use rubber seals to prevent liquid and fine particles from coming in contact with the circuitry.

Tyre Pressure & Safety Information

- Please take the time to choose a suitable location so operation can be performed quickly and safely.
 - Be sure that the LCD monitor is firmly fixed to the windshield or dashboard using the supplied mounting hardware.
 - Please practice safe driving and only take the time necessary to read the information displayed on the screen.
- Ensure the sensors communicate with the LCD monitor before initially fitting them to your tyres to save time and hassle.
- Tyredog TPMS has a unique SecureFit mechanism to prevent sensors from coming loose. You can decide whether to install it or not.
- Regularly check if sensors are fitted tightly. If necessary, spread water with detergent on the valve stem to see if your valves are leaking.
- If a rapid deflation warning sounds, stop the car immediately to check the tyre for damage. Remember to be safe when pulling over.
- The monitor will automatically make connections when it is powered on.
- Many factors can cause tyre pressure to rise and fall. For example, warm weather or long distance trips will lead to a rise in tyre pressure.
- It is normal for tyre pressure to decrease over long periods of time. Periodically re-inflate tyres especially if your car is not regularly driven.
- If you have any questions or problems concerning your unit that are not covered in this manual, please consult your nearest Tyredog dealer.

Item Descriptions

Monitor description

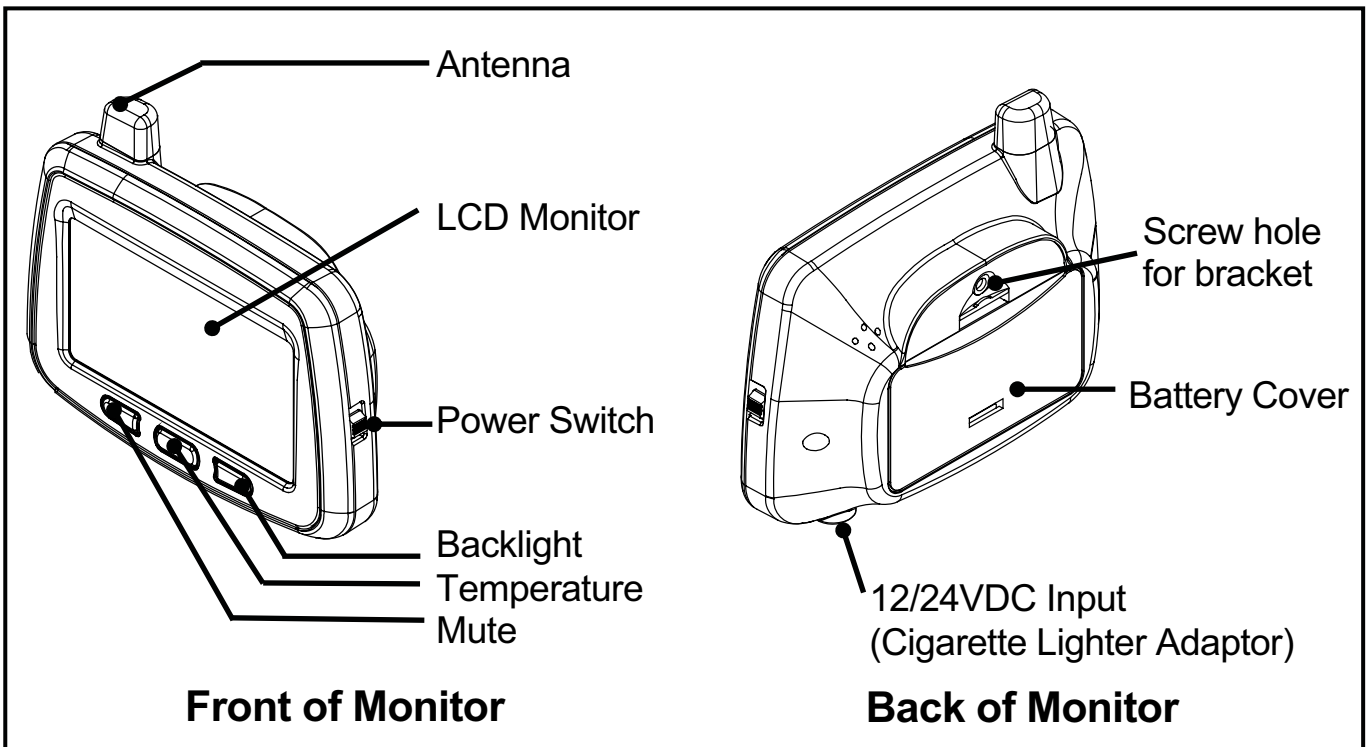

Important Note: The TD-2300A monitor has not been designed to work with Batteries and will only work using the cigarette lighter adaptor.

However for testing, programming and trouble shooting purposes you can insert 2 x AA batteries.

Relay description

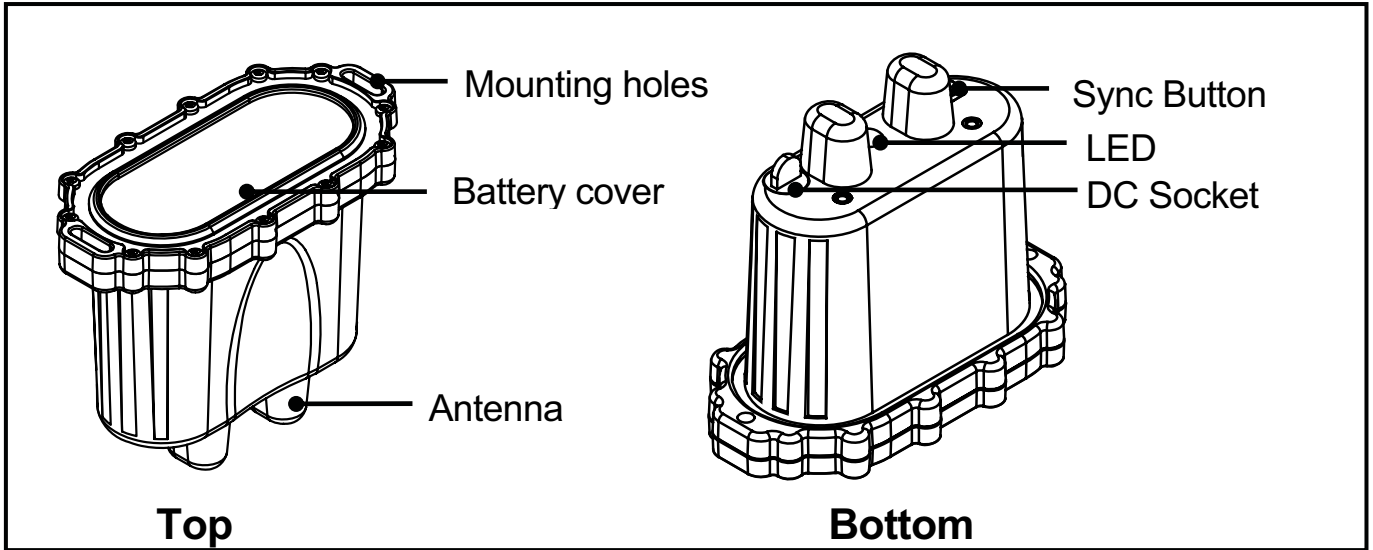

Monitor bracket description

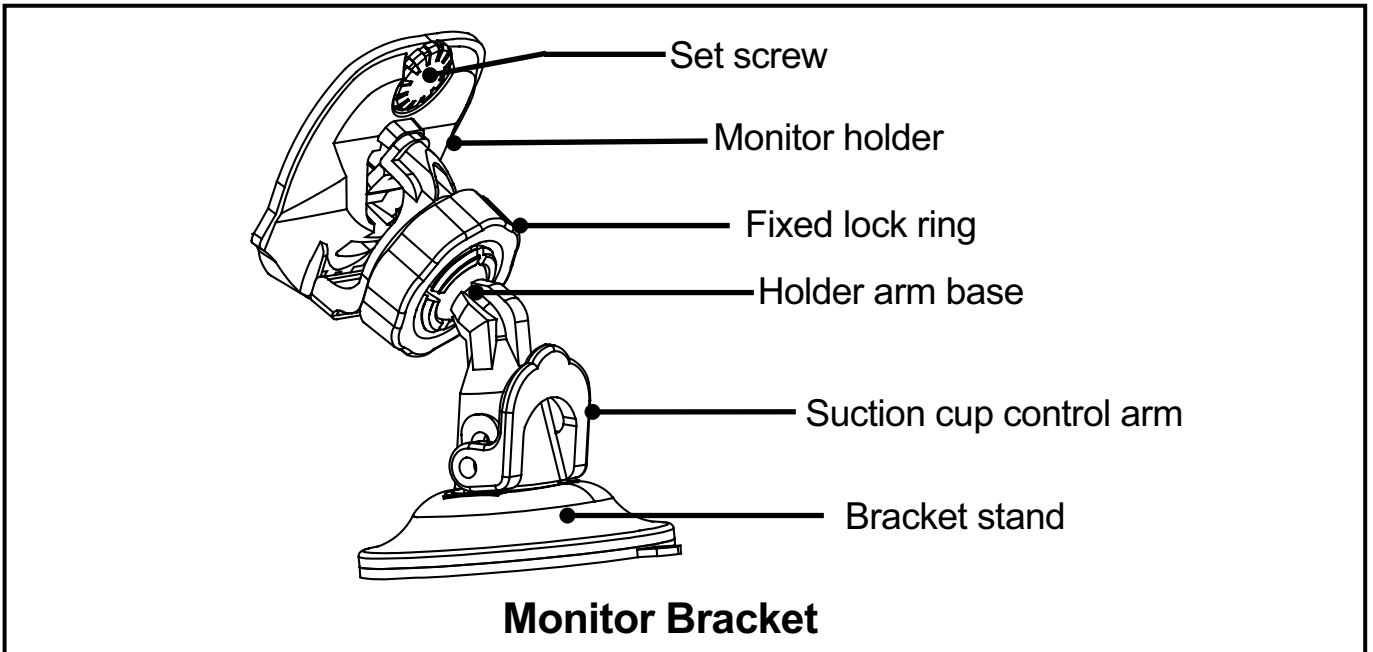

3-way adapter description

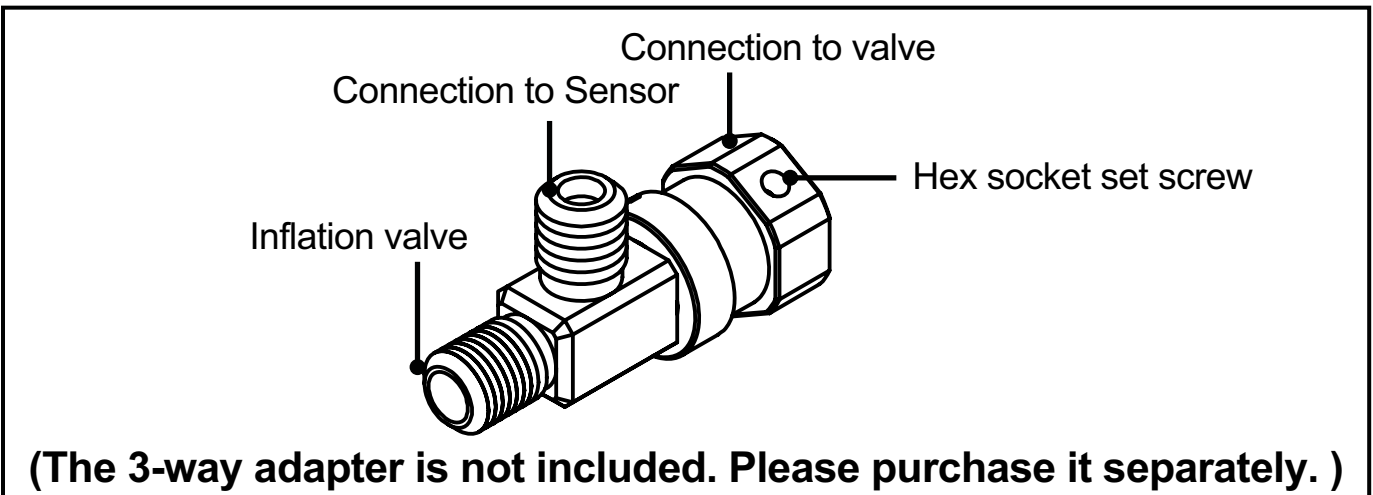

Sensor Description

The sensor has two sections: The sensor cap and sensor body. Its lightweight design and external application is intended to aid D.I.Y. installation.

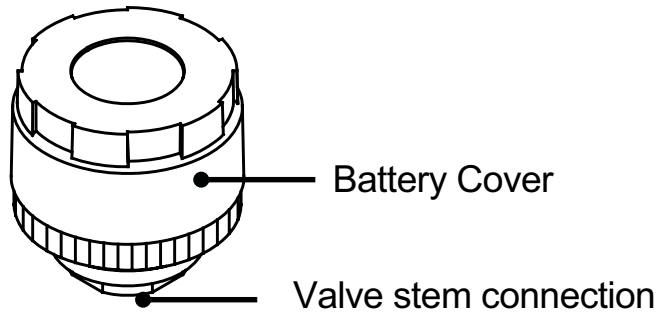

GUI Layout / Icons

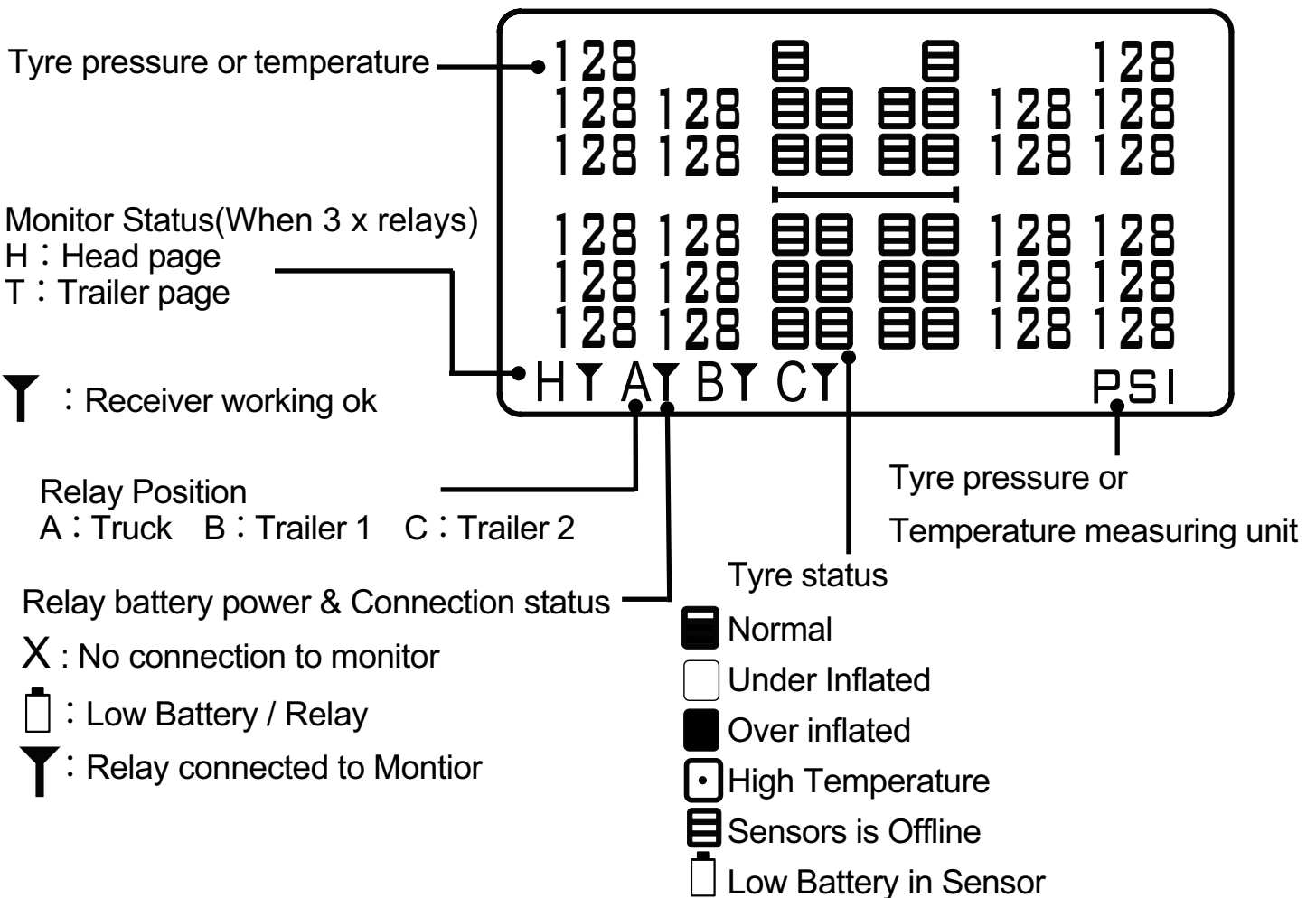

Getting Started

Example Diagram.

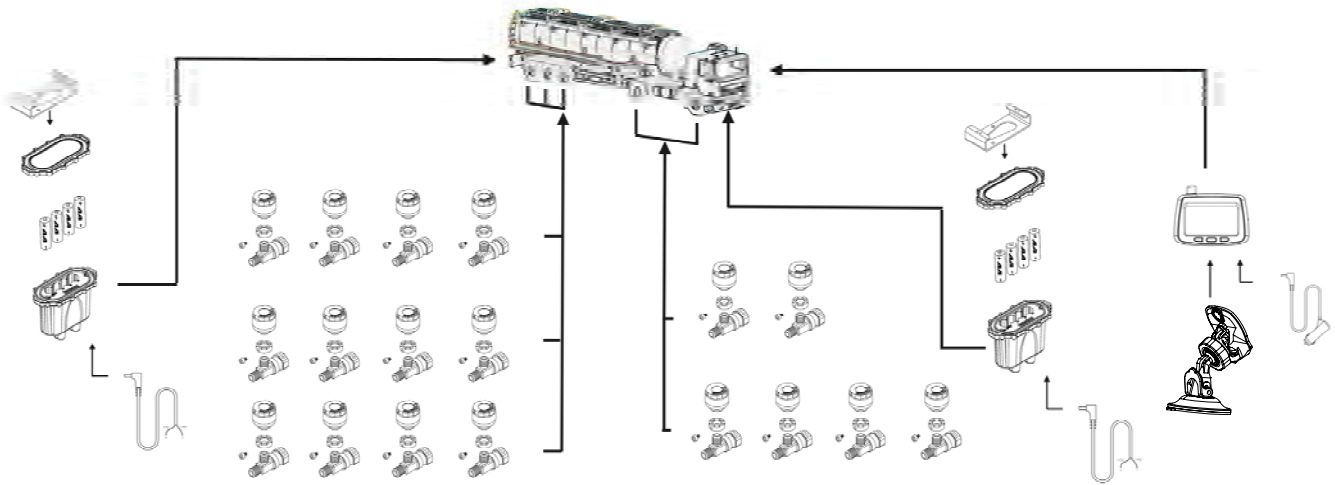

Note : The 3-way adapter is not included and is for illustrative purposes only.

Installation - RELAY

The relay is the main link between the sensors and the monitor. Without it, the system will not function. It is recommended the relay be mounted in a central location with considerably even distance between the furthest forward and furthest rearward sensors.

It is important to remember that sensors connect to the relay they are assigned to. If the relay is removed from the vehicle, the system will not function. This is vital in Truck/Trailer (Car/Trailer) situations when the trailer is often unhitched from the main vehicle. The relay should be mounted at the rear of the vehicle in this case to ensure optimum performance.

Installation - RELAY

The relay can either be powered by 4 x AA batteries or it can be hardwired using the cable supplied.

TIP: If using the hardwired power cable, we recommend that you connect to a permanent 12V/24V supply to ensure correct functionality of the relay.

Connecting to a switched power source such as accessories or ignition, may cause synchronization issues with the monitor when powered up.

BATTERY POWER

To open the battery cover, undo the 12 Philips head screws. Insert the supplied AA batteries into the battery slot observing the polarity markings.

When refitting the battery cover, be sure to line up the contact springs correctly and ensure they are not bent upon contact.

Note: Inserting the battery incorrectly will cause damage to the relay.

Replace the 12 screws removed previously and ensure the rubber o-ring is properly seated prior to tightening.

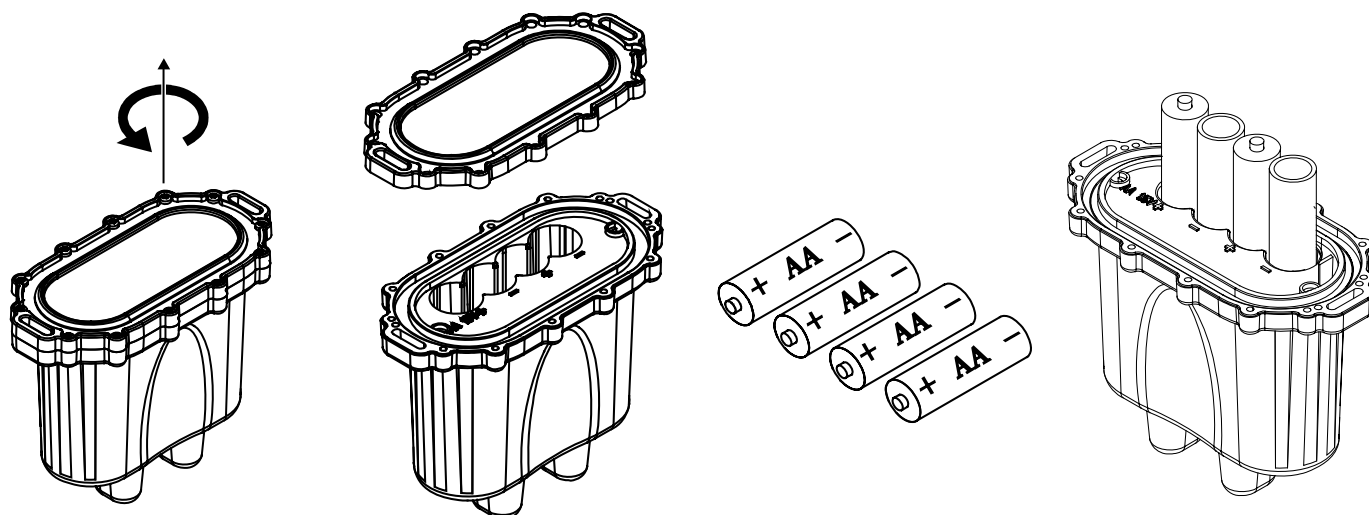

Installation - RELAY Continued..

HARDWIRED (12V/24V)

If using the included power cord, remove the DC socket plug at the bottom of the relay. (If not using the power cord, ensure this socket plug remains fitted as it seals the Relay from water etc.) When plugging in the DC plug, ensure it is plugged in firmly so it will not come loose. When inserted correctly, it will be sealed from water and other elements.

Remove Plug

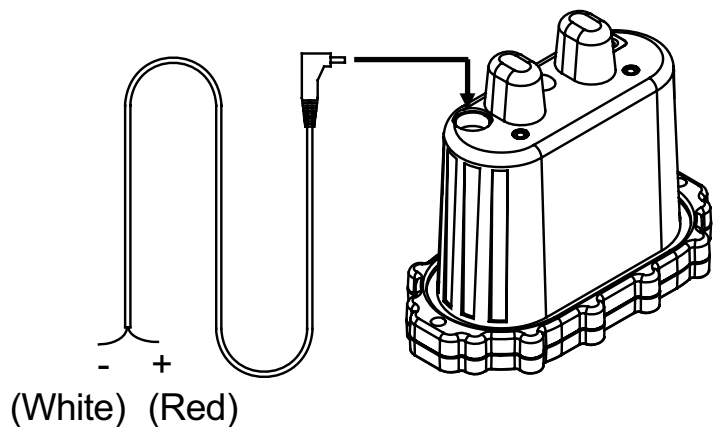
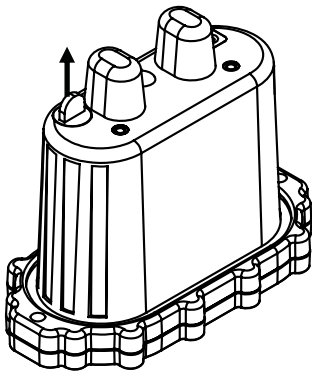

To ensure the relay is protected, we strongly recommend that the Red (+) wire is fused protected. We Recommend adding an inline 3A fuse.

If the relay is hardwired, please ensure there are no batteries fitted to the Relay.

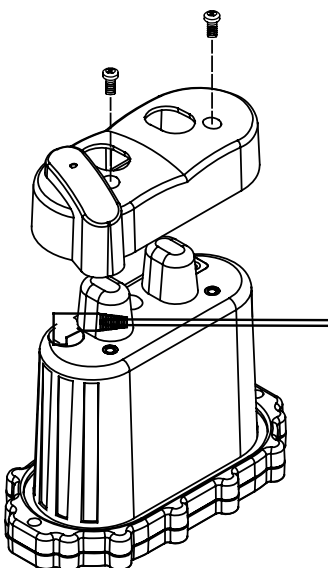

When using the power cord, the supplied bottom cover must be fitted to ensure the D.C. plug does not come loose.

Installation - Mounting the Relay

When fitting the Relay, time and care must be taken to properly decide on a mounting location. Some key factors that must be considered are:

- The Relay must be mounted outside the vehicle. (not under bonnet)
- Total distance between first and last sensors.
- Total distance of car, truck, car + trailer etc.
- Vehicle/trailer structure (chassis/body density etc)

Please remember that any metal between the sensors/relay/monitor may play a part in limiting the signal transmission between Tyredog components.

Although a metal object may not be in the direct line of sight between the components, it may still hinder signal transfer if the object is nearby or offside to the signal transmission path.

When mounting the Relay, be sure that it is mounted away from moving parts, (tail shaft, axle, etc.) sources of heat (exhaust) and is fitted in such a place that would keep it protected from potentially damaging terrain.

The Relay should be mounted using the supplied heavy duty bracket and an existing bolt like shown in the diagram below.

Drilling holes into a vehicle's body/chassis is not recommended as this may affect the structure and your vehicles Warranty.

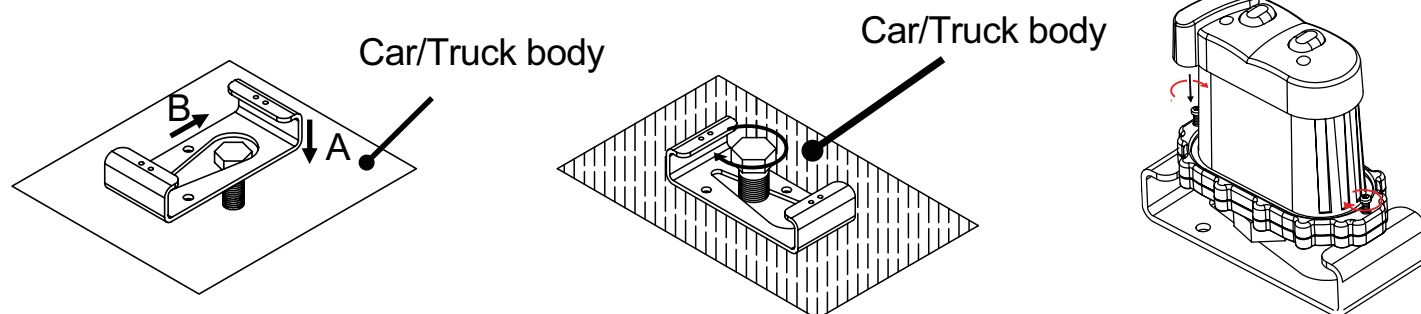

Once the bracket is firmly mounted to the Car/Truck body, the relay can be mounted to the bracket with the supplied screws and washers.

Installation - Monitor / Receiver

The TD-2300A Monitor must be powered up using the cigarette lighter adaptor supplied. Simply plug the power cord into the monitor like shown then connect the cigarette lighter plug to a D.C. Outlet Socket in the vehicle.

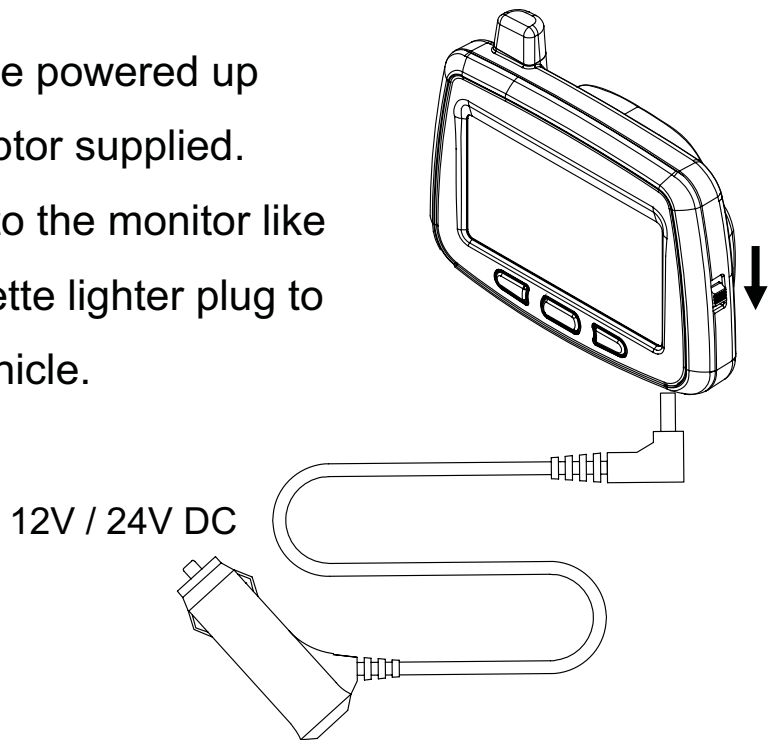

BATTERY POWER

The TD-2300A Monitor has a provision for 2 x AA Batteries which can be inserted for Trouble Shooting and Testing Purposes Only. When the Monitor is using Battery Power, the Monitor will automatically turn off after 60 seconds. Once the monitor turns off, you can press any button and it will turn back on for a further 60 Seconds.

Battery Power can be used for setting the warning thresholds, programming new relays, sensors etc..

Before reconnecting the monitor to hardwire (Cigarette Lighter Plug), we recommend removing the AA Batteries from the Monitor.

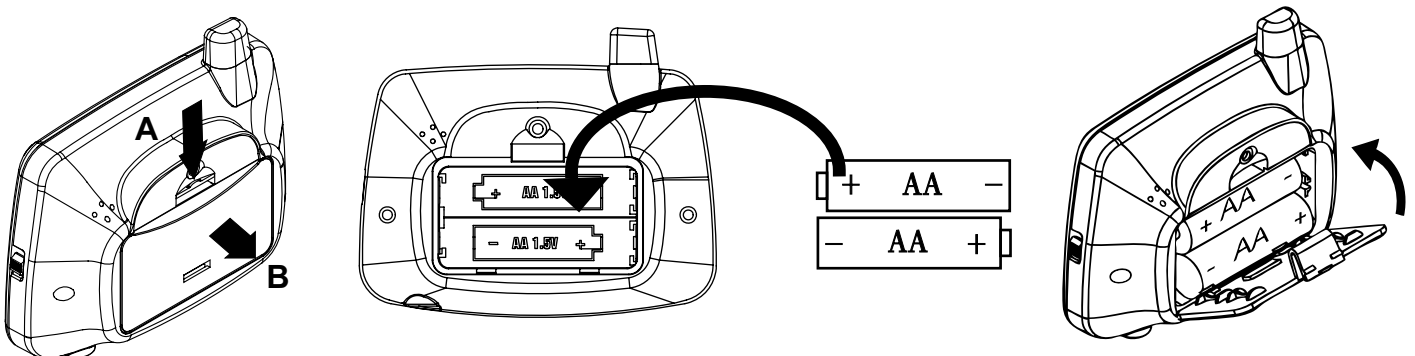

Installation - Monitor / Receiver Bracket

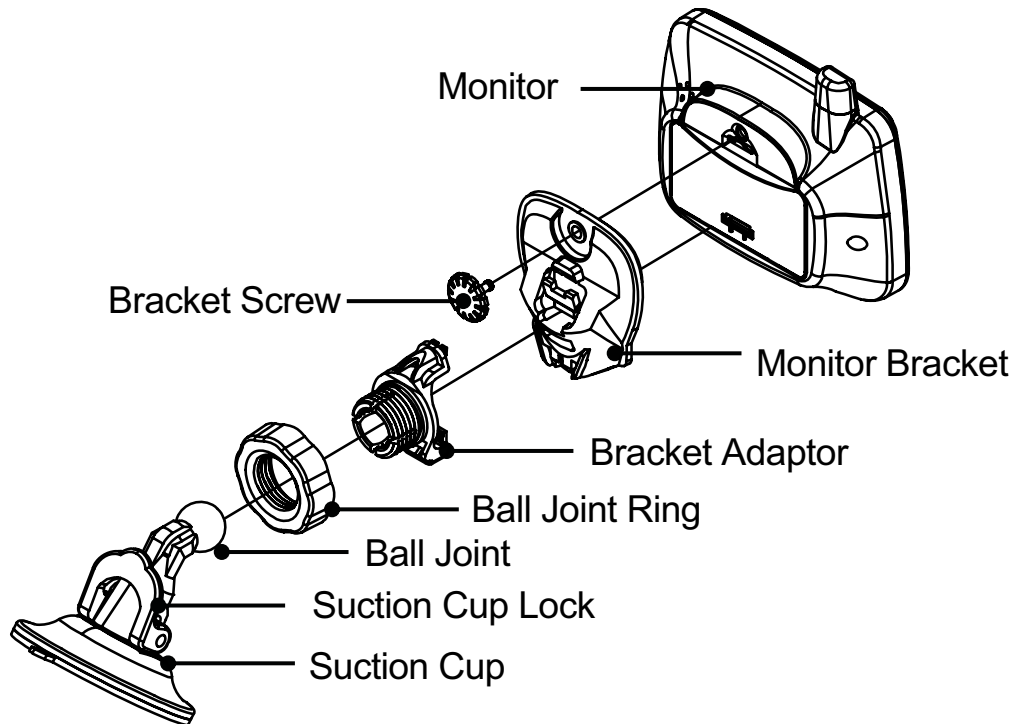

1. Slide the Ball joint ring over the Ball Joint.
2. Insert the Ball Joint into the Bracket Adaptor. You will here it 'Pop In'.
3. Screw the Ball Joint Ring onto the Bracket Adaptor until had tight.

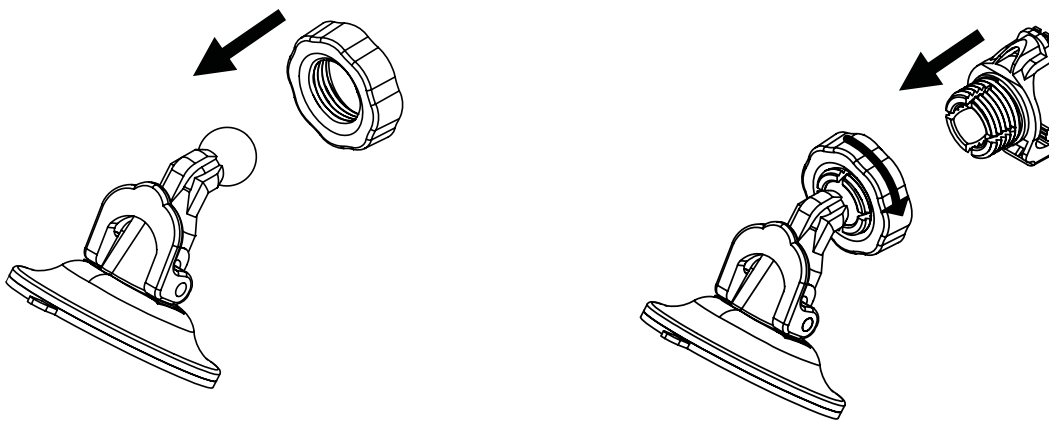

Installation - Monitor / Receiver Bracket

4. Place the Monitor Bracket into the Bracket Adaptor clips.
5. Gently push the Monitor Bracket against the adaptor clips and slide down until the Monitor Bracket locks in place.
6. Now connect the Monitor Bracket to the Monitor and screw it into place.

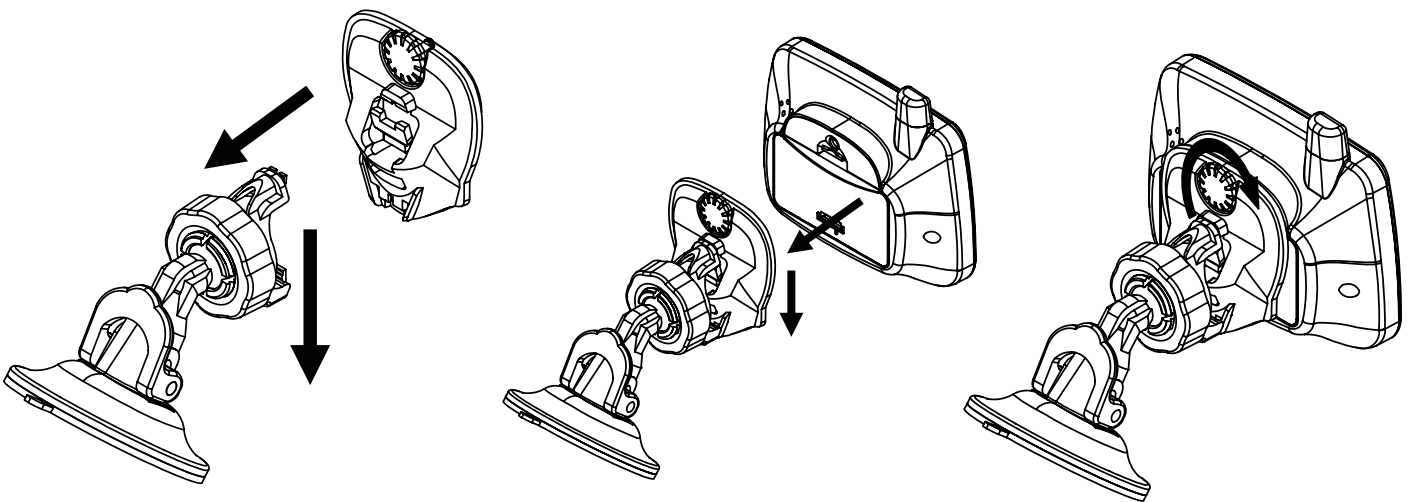

7. Position the Bracket Suction Cup to a suitable location on the windscreen ensuring it doesn't obstruct the view of the driver.
8. Once in position, push down on the base and lower the Suction Cup Lock to apply suction.
9. You can then adjust the monitor angle and tighten the Ball Joint Ring.

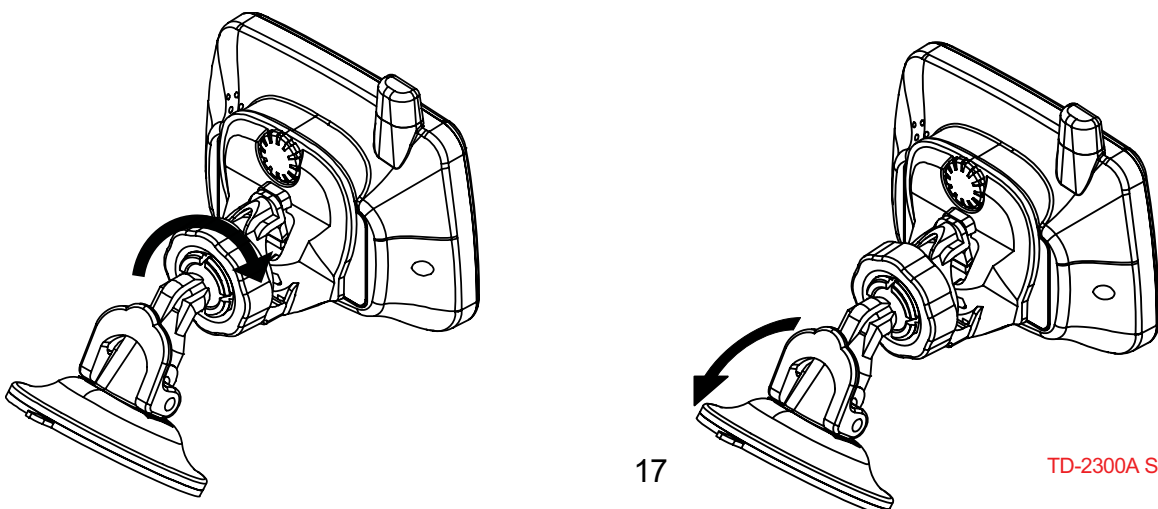

Installation - Sensors

1. Remove the Sensor Cap by rotating the cap anti-clockwise then insert the 3V Lithium Battery (CR1632) like shown below.

Note: Positive (+) of battery should be facing up.

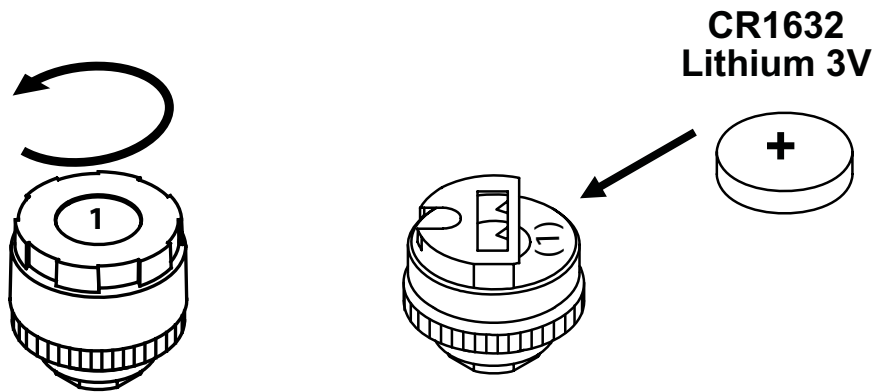

If the Monitor and Relay are both powered up, as soon as the battery is inserted into the sensor, you will hear the monitor beep and you'll see the sensor come online. It will also be flashing 'P.L' and '0'. This indicates the Pressure is Low and it's reading '0' PSI as the sensor has not been fitted to a Tyre.

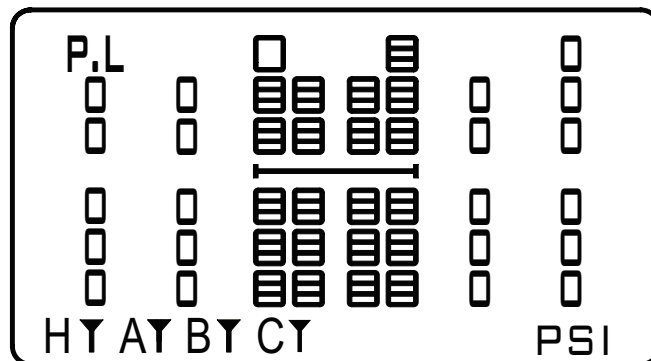

2. Once the Sensor comes online, re-fit the sensor cap ensuring it's nice and tight so no water will get in. (Don't use extreme force though as you don't want to break or crack the cap)
3. Repeat Steps 1 & 2 with the rest of the sensors ensuring you don't mix the sensors and caps up. These are identified with a marking '1 to 12'.

Installation - Sensors Continued..

Before fitting the sensors to the wheels, it's important that you know where each sensor should go.

The Diagram below shows the layout and sensor positions for the maximum 34 Wheel setup.

For all other configurations, start from the top (Front) and go from left to right.

Example 4 Wheel: Front Left Wheel (1), Front Right Wheel (2), Rear Left Wheel (3), Rear Right Wheel (4).

Example 6 Wheel: Front Left Wheel (1), Front Right Wheel (2), Rear Left Outer Wheel (3), Rear Left Inner Wheel (4), Rear Right Inner Wheel (5), Rear Right Outer Wheel (6).

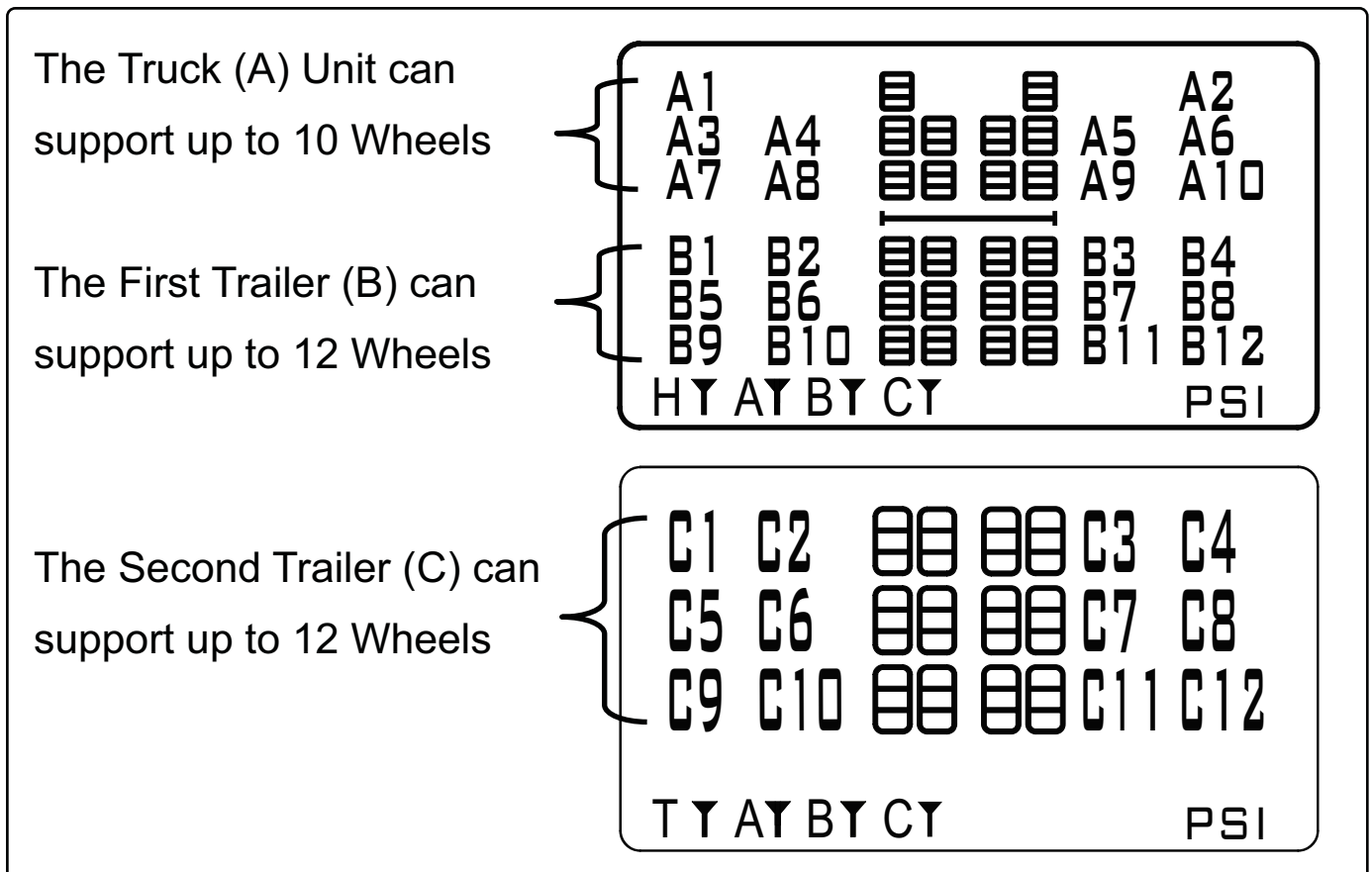

Installation - Sensors Continued..

Visually inspect your tyre's valves for any damage or defects before fitting the sensors to ensure that further damage doesn't occur. If you do notice that something is not right with your valves, have them checked by a tyre professional.

INSTALLATION

1. After removing the original valve caps, slide the SecureFit fixing ring over the valve stem with the flat surface towards the wheel.
2. Screw the Tyredog sensor on in a clockwise direction until you feel the valve stem come under pressure.
3. Slide the SecureFit fixing ring back up to the base of the sensor and line up the grooves. Once locked into place, tighten the hex screw with the supplied Allen key. (Don't over tighten otherwise you might damage your valve stem)

If you do not wish to use the SecureFit fixing ring, only follow step 2.

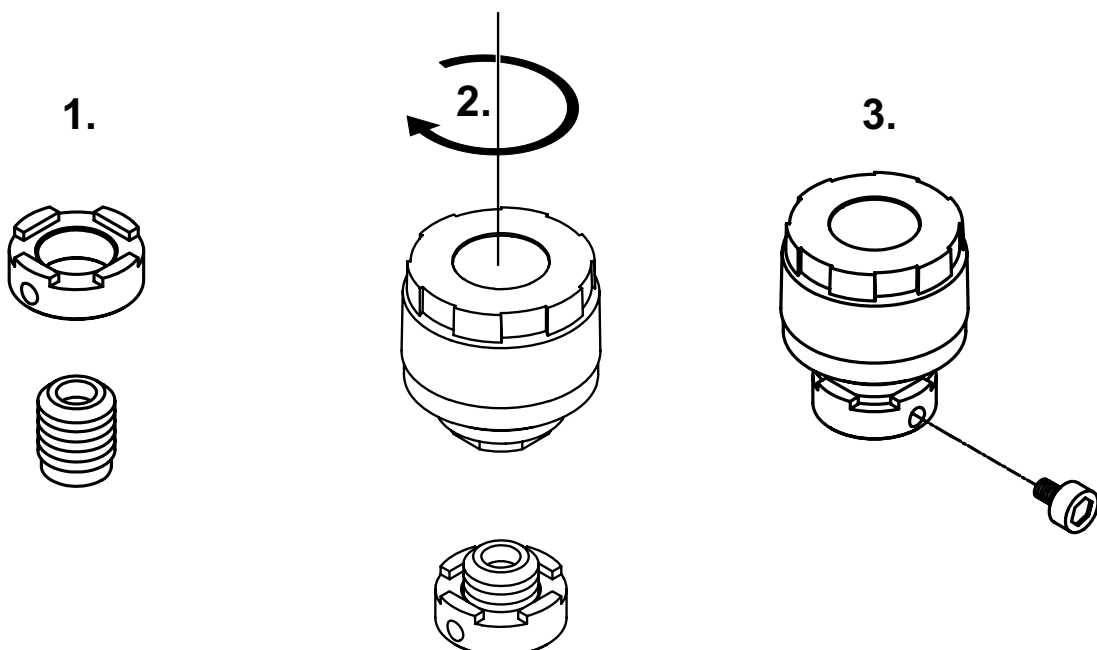

Monitor Switch & Buttons

Button Location and Features

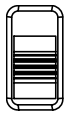
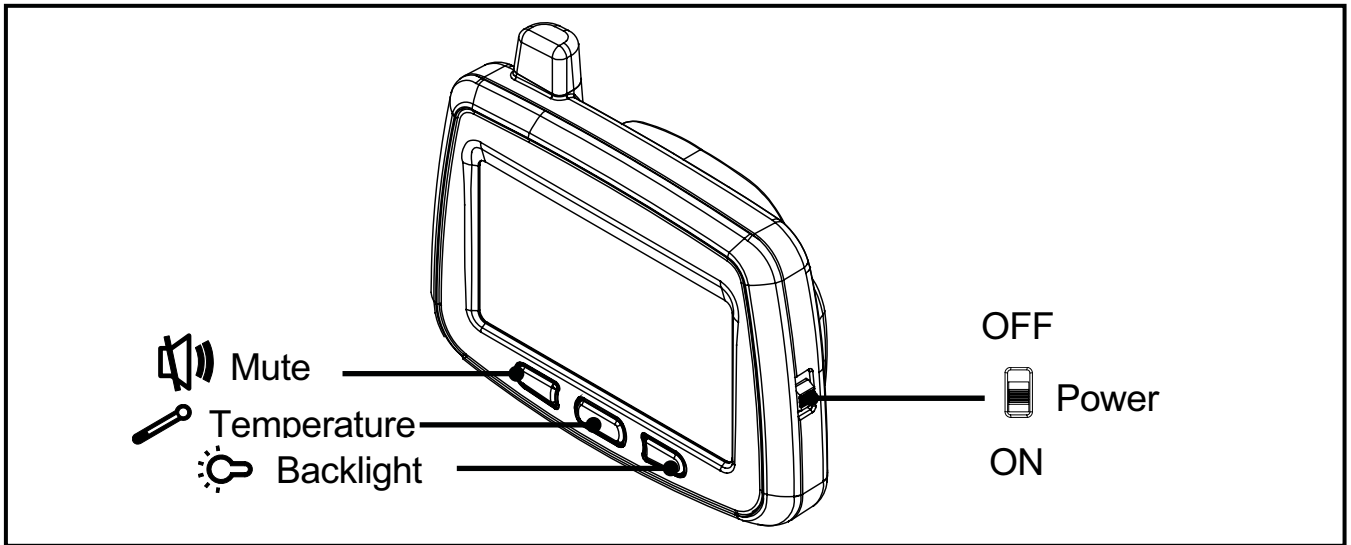

Power switch

When the unit is first switched on, the Monitor will show all sensors offline until it connects to and receives an update from the relay.

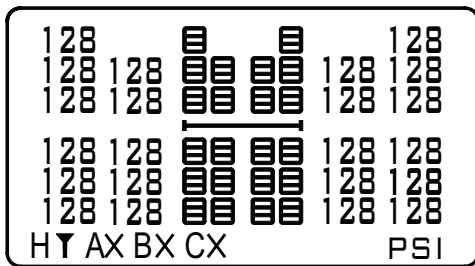

Display showing all sensors and relays offline.

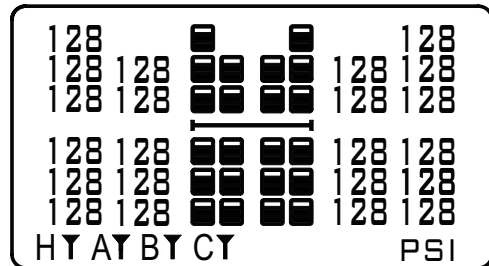

Display showing all sensors and relays online.

Monitor Switch & Buttons Continued..



Mute

When the alarm is sounding for low pressure, high pressure or high temperature, simply press this button once and this will silence / mute the sound until another warning alarm occurs.

You can also press and hold this button for 3 seconds to get into the settings menu.(Refer Page 24)

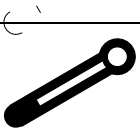

Temperature

Press the Temperature button once and this will display the temperature of each tyre for 10 seconds. (Or push the button again and it will go back to displaying the Pressure)

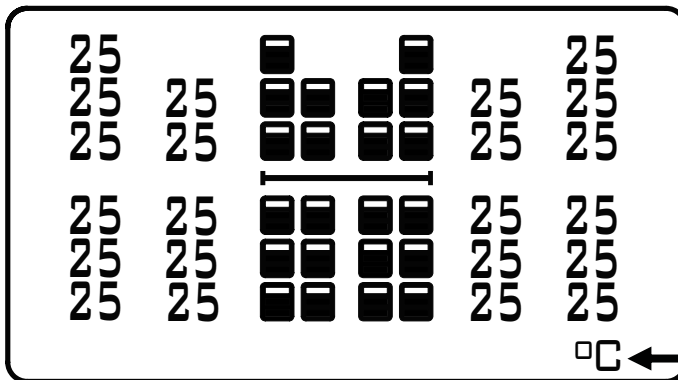

Temperature
measuring unit (°C / °F)

Monitor Switch & Buttons Continued..



- Backlight
- Switch between screen views

Press and hold the Backlight button for 3 seconds to turn the Backlight OFF. Press and hold for 3 seconds to turn it back ON.

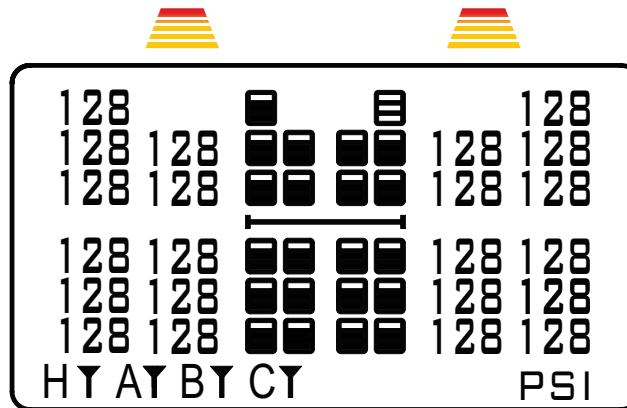

Due to the size of the display, the monitor can only display the first 2 Relays on the home screen. (Truck (A) and Trailer 1(B))

If you have a 3 Relay setup, to view the 3rd Relay simply press the Backlight button once and it will display the Pressure readings.

(Press the Temperature button to view the Temperature while viewing the 3rd Relay (Trailer 2(C)) if you want to see the Temperature readings). Press the Temperature Button once again to go back to the main screen.

Note: If there is a warning alarm, it will automatically display the affected wheel position / screen view.

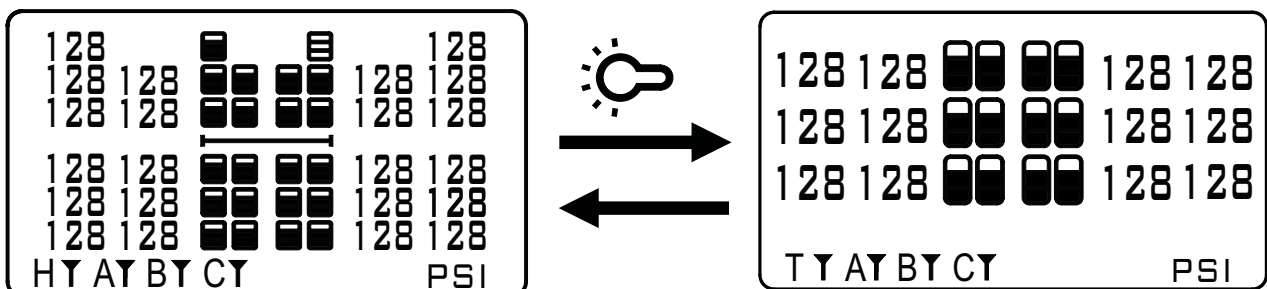

TPMS Settings Menu

To access the Main Settings Menu, press and hold the Mute Button for 3 seconds or until the Menu Screen appears.

From this Menu you can access the following settings:

MAIN MENU OPTIONS



A) Unit Setting - Pressure (PSI/KPA/BAR/KgCm) - Temperature (°C / °F).

B) Threshold of Alarm - Set Low & High Pressure / High Temperature.

C) Type of Vehicle - Set Wheel Layout for each Relay.

D) Add new Relay (Reset/Synch Relay) - Program New or Reset Relay/s.

E) Add new Sensor - Program replacement LEARNABLE Sensors.

Settings			
	Mute	Temperature	Backlight
Settings Menu	>> (Next)	ESC (Escape)	← (Select)
A) Unit Setting	∨ (Next Option)	>> (Change)	← (Enter/Save)
B) Threshold of Alarm	+ (Increase)	- (Decrease)	← (Next Option)
C) Type of Vehicle	∨ (Next)	∧ (Previous)	← (Enter/Save)
D) Add new Relay	∨ (Select Relay)	N/A	ESC (Escape)
E) Add new Sensor	N/A	N/A	ESC (Escape)

Unit Settings

The Tyredog TD-2300A can be set up to display the following Pressure and Temperature units.

Pressure - PSI / KPA / BAR / KgCm



Temperature - °C / °F

The unit is defaulted to display Pressure in PSI and Temperature in °C. If you wish to change this, please follow these steps below.

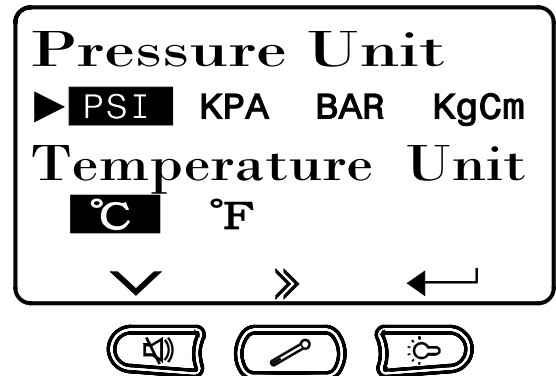
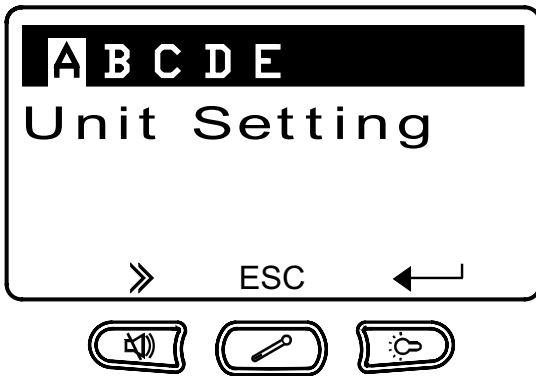
- 1) Press and hold the Mute Button for 3 seconds or until the Menu Screen appears like shown below then Press the Backlight Button to enter Unit Settings.



- 2) Use the Mute Button to select between Pressure and Temperature then press the Temperature Button to select your desired unit of measurement. Once you have made a selection press the Backlight Button to Save/Exit the Unit Setting Menu and return to the Main Menu Screen. From here you can either change more settings or press the Temperature (ESC) Button to exit the Main Menu and return to normal operation.

	Mute	Temperature	Backlight
A) Unit Setting	 (Next Option)	 (Change)	 (Enter/Save)

Threshold Settings

In the Threshold of Alarm settings menu, you can set the following values.

Low Pressure Alarm - Set value for Low Pressure Alarm Warning

High Pressure Alarm - Set value for High Pressure Alarm Warning

High Temperature Alarm - Set value for High Temperature Alarm Warning

These settings can either be applied per axle or for all tyres at once.

If you wish to change any Threshold settings, please refer below.

- 1) Press and hold the Mute Button for 3 seconds or until the Menu Screen appears. Use the Mute Button to select Threshold of Alarm Menu then press the Backlight Button to enter Threshold of Alarm Settings.

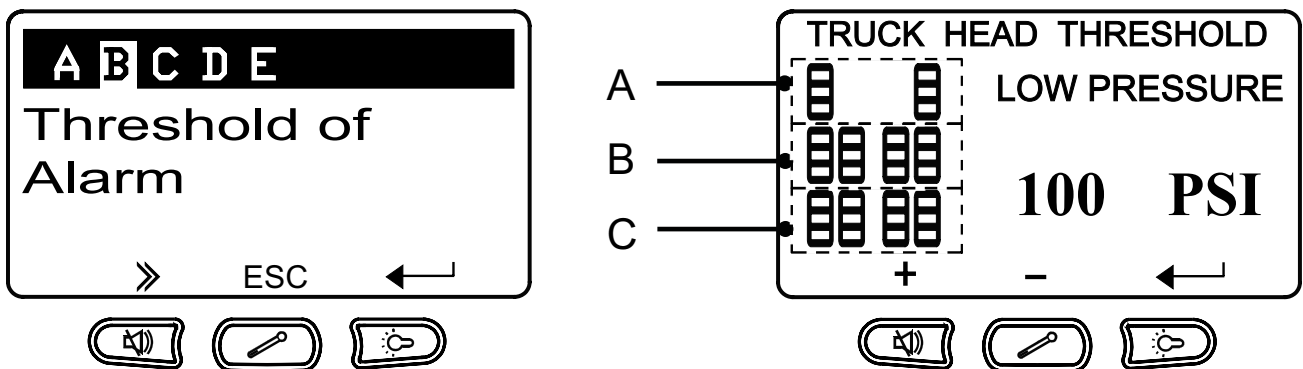

- 2) **Low Pressure value** - Simply use the Mute Button to Increase and the Temperature Button to Decrease the Low Pressure value. Press the Backlight Button to go to High Pressure setting.
High Pressure value - Simply use the Mute Button to Increase and the Temperature Button to Decrease the High Pressure value. Press the Backlight Button to go to High Temperature setting.
High Pressure value - Simply use the Mute Button to Increase and the Temperature Button to Decrease the High Pressure value. Press the Backlight Button to go the Low Pressure setting for the next axle or to save the new values to the Relay.

Threshold Setting Continued..

To set the same Low Pressure, High Pressure and High Temperature values for all Tyres at once, while you're in Threshold of Alarm menu, press and hold the Backlight Button for 3 Seconds or until the display shows ALL TIRES like below then refer to step #2 on page #26.

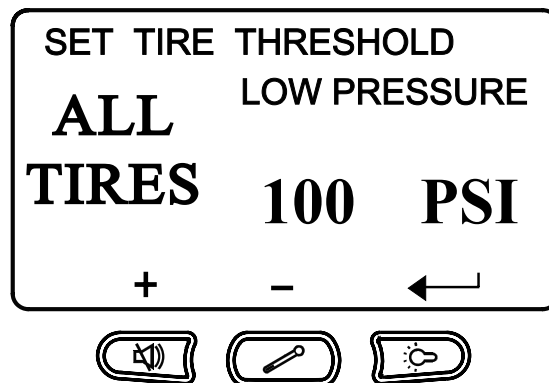

Once you have finished setting all the values for each axle or for all Tyres at once, you will then be prompted to save these values to the Relay. Press the Mute (YES) Button to save these values or if you don't wish to save any changes, press the Backlight (NO) Button.

Note: The Relay must have power and the Monitor must be within range of the Relay otherwise the changes will not be saved.

	Mute	Temperature	Backlight
B) Threshold of Alarm	+ (Increase)	- (Decrease)	← (Next Option)

Type of Vehicle (Wheel Layouts)

The Type of Vehicle settings menu allows you to choose your Vehicle Type / Wheel Layout configuration according to your application.



The TD-2300A-X Series supports up to 34 Wheels and 3 x Relays.

Refer to Page #30 for all available Wheel Layout Configurations.

To change your Type of Vehicle / Wheel Layout, please refer below.

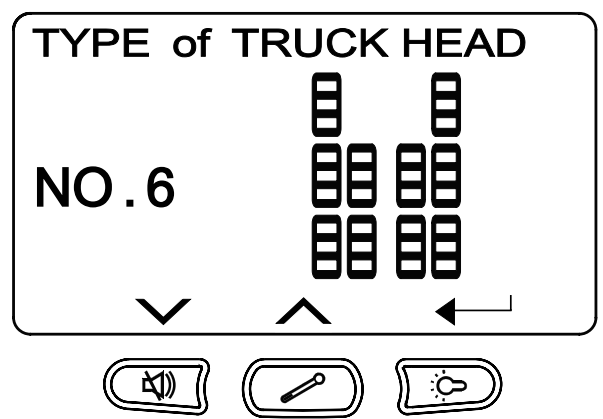
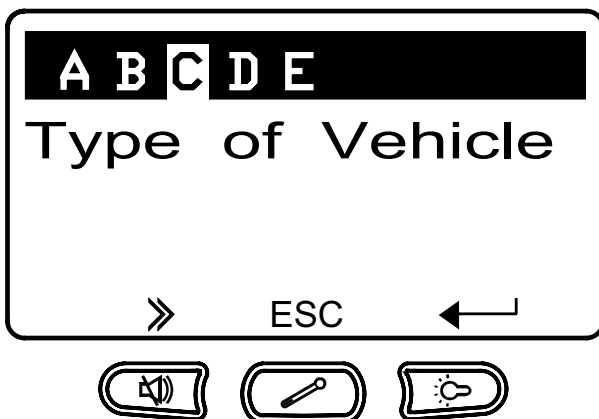
- 1) Press and hold the Mute Button for 3 seconds or until the Menu Screen appears. Use the Mute Button to select Type of Vehicle Menu then press the Backlight Button to enter Type of Vehicle Settings.



	Mute	Temperature	Backlight
C) Type of Vehicle	 (Next)	 (Previous)	 (Enter/Save)

- 2) **Truck Head Relay (A)** - Use the Mute and Temperature Buttons to change the Wheel Layout for this main Relay so it suits your application. Press the Backlight Button to continue.

Trailer 1 Relay (B) - Use the Mute and Temperature Buttons to change the Wheel Layout for Trailer 1 Relay (B). **Note:** If you only have a 1 Relay system, make sure Trailer 1 Relay (B) is set to NO. 1 NONE.

Type of Vehicle (Wheel Layouts) Continued..

Press the Backlight Button to continue. (If Trailer 1 Relay (B) is set to NO. 1 NONE, pressing the Backlight button will take you back to Main menu. *(Now refer to step #3 below)*)

If you do select a Wheel Layout for Trailer 1 Relay (B), once you Press the Backlight button, it will give you the option to configure Trailer 2 Relay (C).

Trailer 2 Relay (C) - Use the Mute and Temperature Buttons to change the Wheel Layout for Trailer 2 Relay (C). **Note:** If you only have a 2 Relay system, make sure Trailer 2 Relay (B) is set to NO. 1 NONE. Once you have selected the Wheel Layout for Trailer 2 Relay (C), press the Backlight Button and it will ask you want DISABLE or ENABLE the Switchable Trailer Feature. Use the Mute Button to select between DISBALE and ENABLE and press the backlight Button to Save and return to the Main Menu. (For further information regarding Switchable Trailer feature, please speak to your Authorised Tyredog Dealer)

Select **DISABLE** if you only have a Tyredog unit fitted to 1 Trailer.

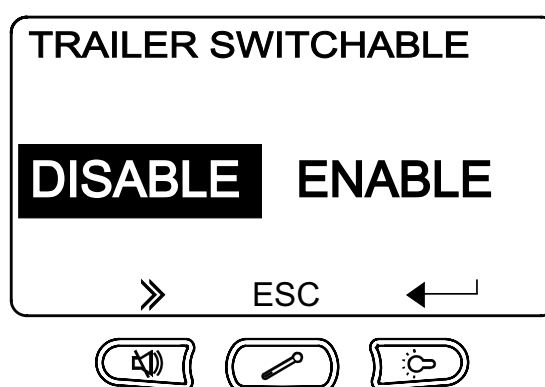

Select **ENABLE** if you have multiple Trailers which are fitted with Tyredog Relay Kits. This allows the monitor to auto detect and connect to your other trailers when you change over Trailers.

- 3) Once you have returned to the Main Menu, **you now must save these new Wheel Layout settings to the Relay (Reset Relay)** otherwise the unit will default back to the old / original Wheel Layouts. To save the new Layouts, please refer to Add new Relay Section on page #31.

Type of Vehicle (Wheel Layouts) Continued..

TD-2300A-X Series Car/Truck & Trailer Wheel Layout Options

	No.1	No.2	No.3	No.4	No.5	No.6
Truck Head Relay (A)						

	No.1	No.2	No.3	No.4	No.5	No.6
Trailer 1 Relay (B)	NONE					
AND	No.7	No.8	No.9	No.10	No.11	No.12
Trailer 2 Relay (C)						
	No.13	No.14	No.15			

TIPS: If you ever change the Type of Vehicle (Wheel Layout), you may have re-enter all your Threshold settings. (Especially if there are more or less axles in the new layout)

Also when changing any Wheel Layouts, please remember to save them to the Relay (Reset). This is explained on the next page.

Add new Relay (Reset Relay)

The Add new Relay function can be used for the following situations:

- 1) Adding new Relays to your system.
- 2) Resetting / Re-programming your existing Relay.
- 3) Save new Wheel Layout settings to each Relay.

Before you proceed any further please make sure your Type of Vehicle (Wheel Layout) is set up correctly (refer pages #28 - #30) as the procedure shown below will save these Wheel Layouts to the Relay/s.

To Add a New Relay, Reset a Relay or Save new Type of Vehicle (Wheel Layouts) please refer below.

Note: The Relay must have power and the Monitor must be within range of the Relay otherwise this procedure will not work.

- 1) Press and hold the Mute Button for 3 seconds or until the Menu Screen appears. Use the Mute Button to select Add new Relay Menu then press the Backlight Button to enter Add new Relay Settings.



	Mute	Temperature	Backlight
D) Add new Relay	 (Select Relay)	N/A	ESC (Escape)

Add new Relay (Reset Relay) Continued..

2) To program a New Relay, Reset a Relay or Save new Wheel Layouts to a Relay, firstly make sure the Display shows the correct Relay Location. Use the Mute Button to select between Truck Head Relay (A), Trailer 1 Relay (B) or Trailer 2 Relay (C).

If your Type of Vehicle (Wheel Layout) only consists of 1 Relay then you will only have the option to Program / Reset / Save new settings to the Truck Head Relay (A). If your Type of vehicle (Wheel Layout) consists of multiple Relays then you will have the option to Program / Reset / Save new settings to the Trailer Relay/s too.

3) Once the correct Relay/Location is selected, press the Reset Button on the corresponding Relay. The LED will light up and the Monitor will beep to confirm that the Relay has been added, reset or new settings were saved. Repeat this step for all other relays in your system if required. (Remember to make sure the Relay Location on the Display matches the Relay you're programming before pressing the Reset Button.

If you do program the wrong relay to the wrong location, don't worry as you can always go back and re-program it correctly.

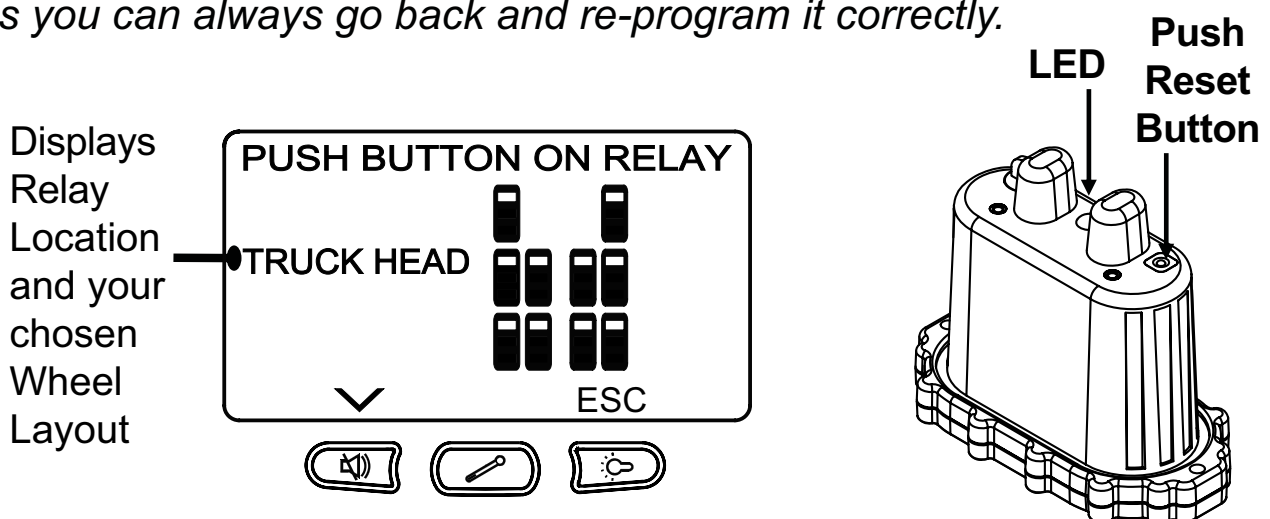

4) Once you've finished, press the Backlight (ESC) Button to exit menu.

Add new Sensor (LEARNABLE)

In the Add new Sensor menu, you can program new / replacement LEARNABLE sensors.

You cannot re-program old sensors back in or sensors from another TD-2300A-X Series Kit. They must be LEARNABLE type sensors only.

Replacement LEARNABLE sensors can be purchased through your authorised Tyredog Dealer or online at www.tyredog.com.au.

When ordering replacement LEARNABLE sensors, you must order the correct wheel position. (Which is marked on your sensor Cap)

Please refer below for the LEARNABLE sensor Part Numbers:

P/N	POSITION
TD-SN-2300A-X1	Wheel 1 (433Mhz)
TD-SN-2300A-X2	Wheel 2 (433Mhz)
TD-SN-2300A-X3	Wheel 3 (433Mhz)
TD-SN-2300A-X4	Wheel 4 (433Mhz)
TD-SN-2300A-X5	Wheel 5 (433Mhz)
TD-SN-2300A-X6	Wheel 6 (433Mhz)
TD-SN-2300A-X7	Wheel 7 (433Mhz)
TD-SN-2300A-X8	Wheel 8 (433Mhz)
TD-SN-2300A-X9	Wheel 9 (433Mhz)
TD-SN-2300A-X10	Wheel 10 (433Mhz)
TD-SN-2300A-X11	Wheel 11 (433Mhz)
TD-SN-2300A-X12	Wheel 12 (433Mhz)

Add new Sensor (LEARNABLE) Continued..

Once you have your new LEARNABLE replacement sensor, please follow the steps below.

Note: The Relay must have power and the Monitor must be within range of the Relay otherwise the procedure below will not work.

- 1) Press and hold the Mute Button for 3 seconds or until the Menu Screen appears. Use the Mute Button to select Add new Sensor Menu then press the Backlight Button to enter Add new Sensor Settings.

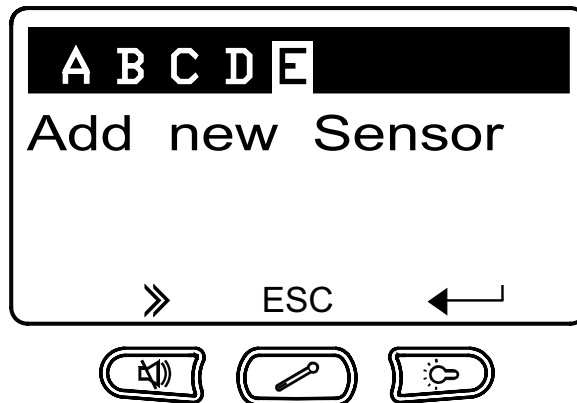

	Mute	Temperature	Backlight
E) Add new Sensor	N/A	N/A	ESC (Escape)

- 2) Now Press the Reset Button on the Relay which requires the new LEARNABLE sensor. Monitor will Beep and LED on Relay will illuminate Red.



Press the reset button on the relay

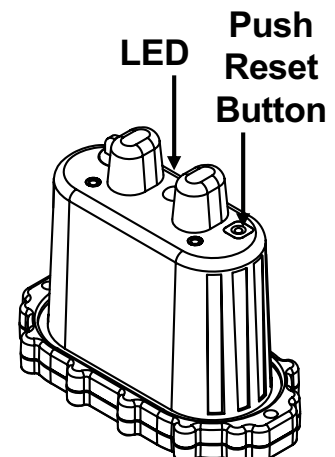

Add new Sensor (LEARNABLE) Continued..

3) While the Red LED on the Relay is still illuminated, insert a Battery into the LEARNABLE sensor like shown below. Once you insert the Battery, the monitor will Beep once. **Now Press the Reset Button again on the relay and make sure the Red LED turns OFF and this will complete the Learning Process.**

Note: If the LED on the Relay turns off before you have a chance to insert the Battery into the Sensor, simply press the Reset button on the Relay again. (The LED stays Illuminated for 50 Seconds)

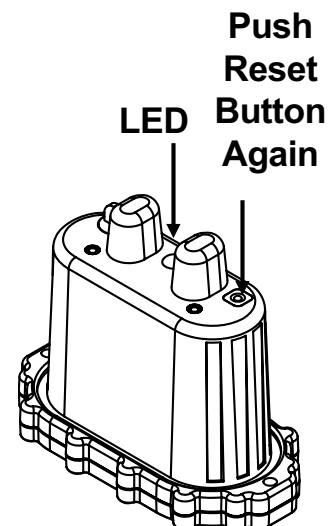
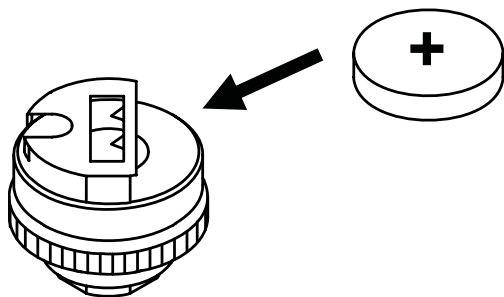

While in Sensor Learn mode, the Display will look like this. It will either say Truck Head, Trailer 1 or Trailer 2. Depending on which relay you are programming the sensor into.

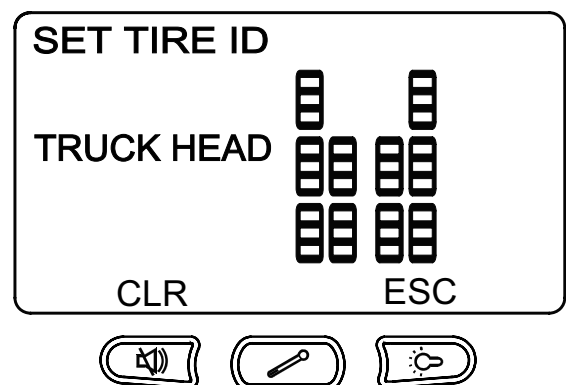

3) Once the LEARNABLE sensor has been programmed, simply press the Backlight (ESC) Button to exit.

How to use your TPMS system

When you first switch on your TPMS system, the screen will look similar to the example shown below. (Depending on your Type of Vehicle (Wheel Layout)).

Typical Start-up screen when first switched on

'H' Means the display is showing the Truck Head & Trailer 1 Relay Layout.

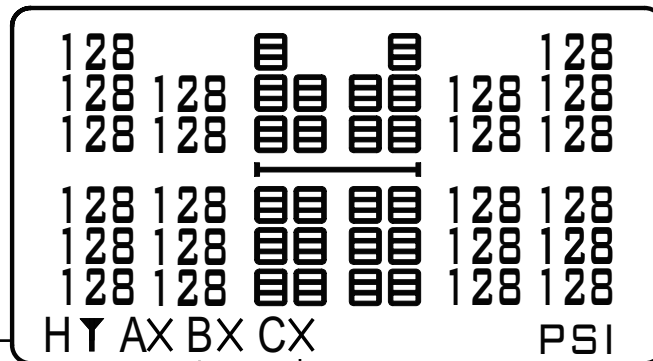

'↑' Symbol shows Monitor Receiver is working. This symbol will Flash.

'X' Means Relay not Connected
 'A' Indicates Truck Head Relay
 'B' Indicates Trailer 1 Relay
 'C' Indicates Trailer 2 Relay

Note: The Display will show the last PSI readings while Relay/Sensors are offline.

Typical screen after Relay Connects and Sensors are Online

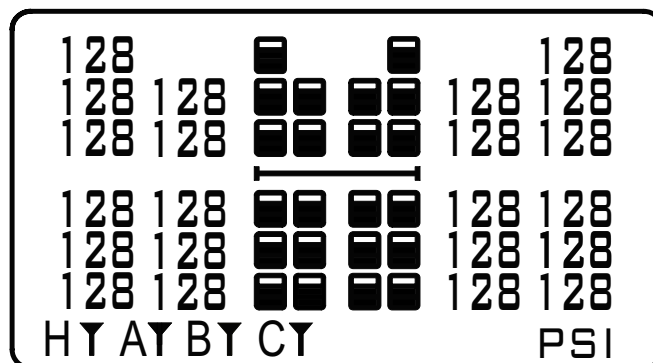

'↑' Means Relay is Connected

How to use your TPMS system Continued..

Now you know what the screen should look like when the Relay/s are connected and Sensors are Online, please refer below so you can understand how all the warnings work.

1) Low Pressure Warning / Indication

(Example when Low Pressure Threshold is set to 100 PSI)

If the Tyre Pressure drops below your Low Pressure Threshold setting, the Monitor will start Beeping and the affected wheel position will Flash between the actual Tyre pressure reading and P.L. (P.L. meaning Pressure Low). The Tyre symbol on the Monitor will also change to indicate the Tyre Pressure is Low. So this means you have both an Audible and Visual warning that there is something wrong with your Tyre. Check out the Screen shots below.

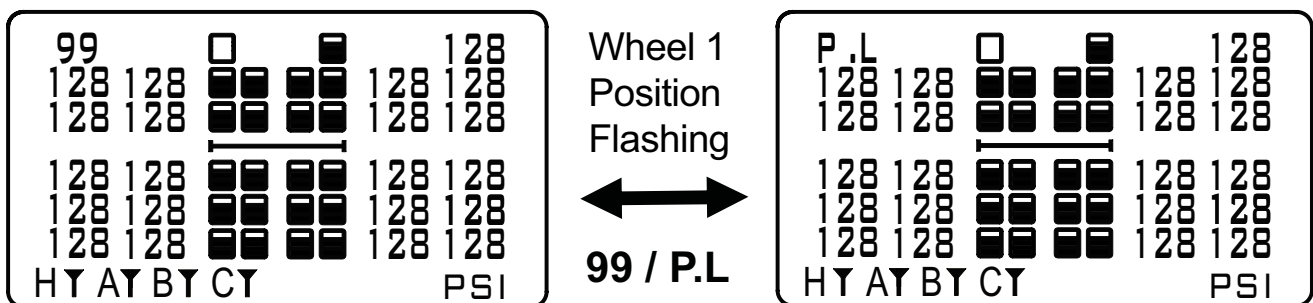

To stop the Monitor from Beeping, simply press the Mute Button. The Monitor will still show the visual indication.

If the Pressure continues to drop below the Low Pressure Threshold setting, it will continue to Alarm and Warn you. (Warning Signs!!)

The only way to stop it from Alarming / Warning you is to bring your Tyre Pressure back up above the Low Pressure Threshold setting. This could mean that you have to inflate your Tyre or get it replaced or repaired if the Tyre has blown out or is damaged.

How to use your TPMS system Continued..

2) High Pressure Warning / Indication

(Example when High Pressure Threshold is set to 140 PSI)

If the Tyre Pressure raises above your High Pressure Threshold setting, the Monitor will start Beeping and the affected wheel position will Flash between the actual Tyre pressure reading and P.H. (P.H. meaning Pressure High). The Tyre symbol on the Monitor will also change to indicate the Tyre Pressure is to High. So this means you have both an Audible and Visual warning that there is something wrong with your Tyre. Check out the Screen shots below.

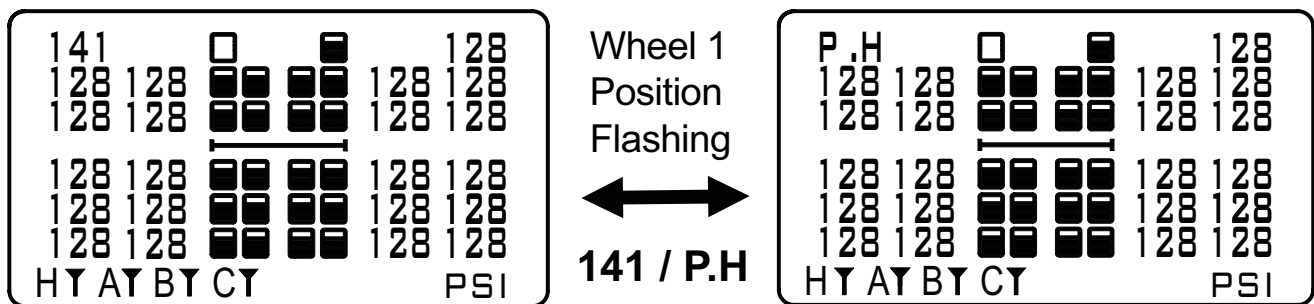

To stop the Monitor from Beeping, simply press the Mute Button. The Monitor will still show the visual indication.

If the Pressure continues to raise above the High Pressure Threshold setting, it will continue to Alarm and Warn you. (Warning Signs!!)

The only way to stop it from Alarming / Warning you is to bring your Tyre Pressure back below the High Pressure Threshold setting. This could mean that you might have to deflate your Tyre or allow them to cool down. Also check your Threshold settings and make sure your High Pressure Threshold setting is set correctly as it's normal for Tyre Pressure to increase slightly while driving and in higher temperatures.

How to use your TPMS system Continued..

3) High Temperature Warning / Indication

(Example when High Temperature Threshold is set to 70 deg C)

If the Tyre Temperature raises above your High Temperature Threshold setting, the Monitor will start Beeping and the affected wheel position will Flash between the actual Tyre pressure reading and T.H. (T.H. meaning Temperature High). The Tyre symbol on the Monitor will also change to indicate the Tyre Temperature is to High. So this means you have both an Audible and Visual warning that there is something wrong with your Tyre. Check out the Screen shots below.

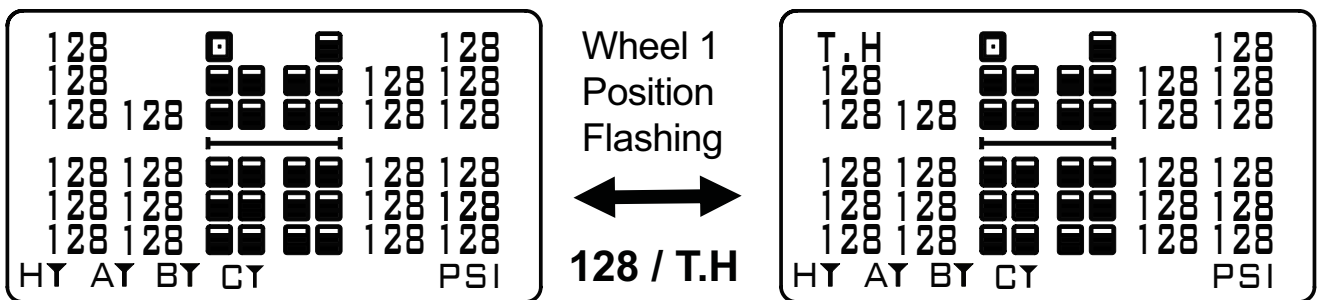

To see the actual Temperature reading of the affected wheel, you will need to press the Temperature button.

To stop the Monitor from Beeping, simply press the Mute Button. The Monitor will still show the visual indication.

If the Temperature continues to raise above the High Temperature Threshold setting, it will continue to Alarm and Warn you. (Warning Signs!!)

The only way to stop it from Alarming / Warning you is to bring your Tyre Temperature back below the High Temperature Threshold setting.

This could mean that you might have to pull over (When safe to do so) and check for any signs of damage or allow them to cool down.

High Tyre Temperature could be an early sign for a potential blowout.

How to use your TPMS system Continued..

4) Low Battery Warning / Indication

The TD-23000A Monitor will warn you when the Batteries in the Sensors, Relay and Monitor are getting low. Refer to Examples below.

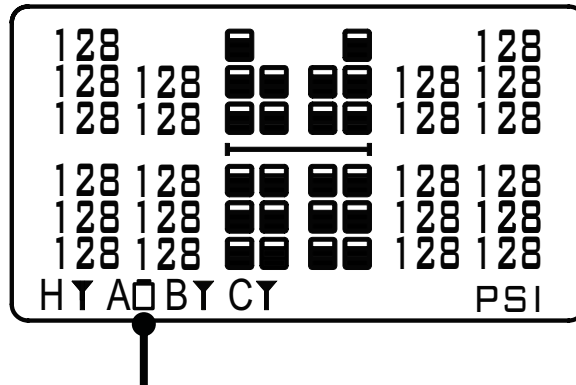

Example Truck Head **Relay** (A) Low Battery Warning.
Will Flash Between '□' and 'Υ'.

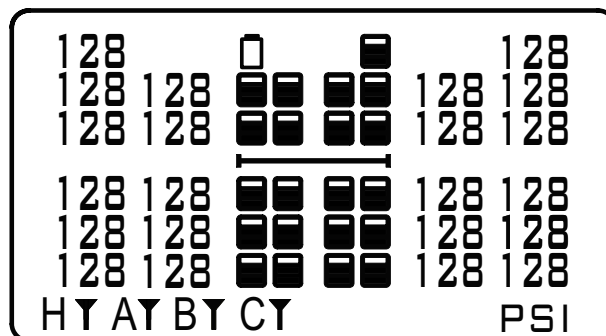

Example Wheel **Sensor** 1 Low Battery Warning.
Will Flash Between '□' and '■'.

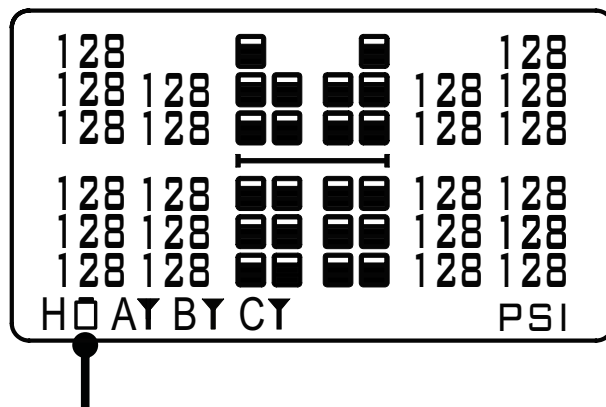

Example **Monitor** Low Battery Warning.
Will Flash Between '□' and 'Υ'.

Troubleshooting

Here we have listed some possible questions or scenarios you may encounter with your TPMS system.

1) One or More Sensors will not come online.

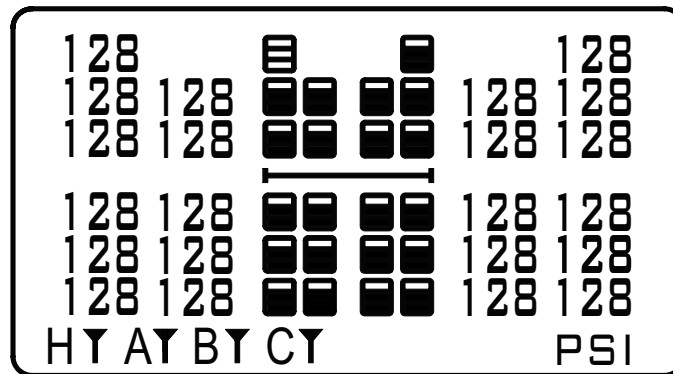

Example Shows Sensor 1 is Offline

What can I do?

Most of the time if a sensor doesn't come online it's usually due to a Low Battery problem. To check this you can try a new Battery (CR1632 3V). If you don't have a new battery simply remove a Battery from a known working Sensor and try this.

If replacing the Battery doesn't fix the problem then please contact your authorised Tyredog dealer.

TIP: Flat Batteries in Sensors may cause erratic readings or connection issues to the monitor. So if you notice the Low Battery Symbol appear on the monitor we recommend that you replace the sensor battery as soon as you can.

Troubleshooting Continued..

2) All Sensors from 1 of the Relays are Offline / Relay Offline.

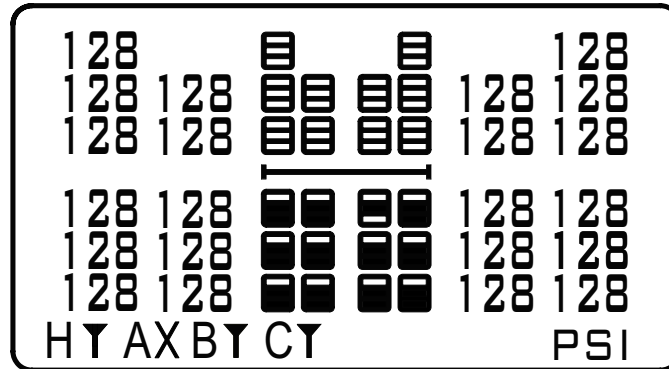

Example Shows all Sensors from 1 Relay are Offline

What can I do?

If All of your sensors from 1 Relay are Offline, this generally means that the Relay hasn't connected to the Monitor. (Relay has no Power)

This can be determined by checking the Relay status Symbol. If a 'X' is shown, this means there is definitely no connection.

Please check the following:

If the Relay is powered by 4 x AA Batteries, please replace with new Batteries and test again. (Also check Batteries are inserted the correct way)

If the Relay is hardwired, please check that the Relay is getting power.

You can do this by making sure the D.C. plug is still plugged in properly and if a fuse was installed, check that the fuse hasn't blown.

Once you are sure that the Relay is getting power and if it still won't connect to the Monitor, try resetting/programming the Relay. Refer Page #31.

If none of these recommendations fix the problem then please contact your authorised Tyredog dealer.

Troubleshooting Continued..

3) Sensor is Online but is not Reading Pressure

What can I do?

Firstly make sure the Sensor is screwed on properly. If it's not screwed on enough to open the valve then it cannot read pressure.

You can then try fitting the sensor to another Tyre to see whether it's a Sensor problem or Valve problem.

If the sensor still doesn't read pressure on another Tyre, please try a new Battery (CR1632 3V). If you don't have a new battery simply remove a Battery from a known working Sensor and try this.

If you tried the Sensor on another Tyre and it read pressure ok, then it's possible that the Sensor can't release the valve on that particular Tyre.

A Tyre fitter / Repair shop should be able to resolve this issue.

4) Erratic / Inaccurate Pressure Readings.

What can I do?

Firstly make sure the Sensor is screwed on properly. If it's not screwed on enough, this will cause Erratic pressure readings.

If the sensor still causes Erratic readings, please try a new Battery (CR1632 3V). If you don't have a new battery simply remove a Battery from a known working Sensor and try this.

You can also check Relay Connection Status and Power. (Especially if you're using AA Batteries to power the Relay)

If none of these recommendations fix the problem then please contact your authorised Tyredog dealer.

TroubleShooting Continued..

5) Wheel Layout keeps defaulting back to the old Wheel Layout

What can I do?

If you ever change the Wheel Layout configuration in the Type of vehicle menu, you must reset /save these new layouts to the Relay/s. Refer Page #31.

6) I can't Program / Add a new Sensor

What can I do?

To program new Sensors, they must be a LEARNABLE TD-SN-2300A-X type Sensor only. Please refer to Pages #33 - #35 and make sure the full procedure was followed.

7) I can't Program / Add a new Relay

What can I do?

To program new Relay/s, they must be a TD-RLY-2300A type Relay only. Make sure Relay/s have power and Batteries are not flat.

Please refer to Pages #31 - #32 and make sure the full procedure was followed.

8) What happens if I lose or damage a Sensor

What can I do?

If a Sensor is lost or Damaged you can order a replacement LEARNABLE sensor. Please refer to page #33 for further information.

TroubleShooting Continued..

9) Can I upgrade my TD-2300A-X system?

What can I do?

Yes you can. Example: If you have a 6 Wheel TD-2300A-X system you can convert it to a 10 Wheel system by ordering LEARNABLE sensors 7,8,9,10 and programming them in using the Add new Sensor Menu.

You can also add up to 2 additional Relay Kits (Trailer Kits).

The TD-2300A-X can support up to 3 Relays and can monitor 4 to 34 Wheels.

10) The Monitor keeps turning OFF after 50 Seconds

What can I do?





The TD-2300A Monitor is designed to run off 12V/24V DC hardwired power (Using Cigarette Lighter Adaptor).

If you use Batteries in the Monitor it will turn OFF 50 Seconds after the last Press of any Button.

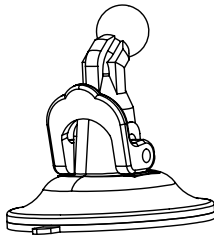
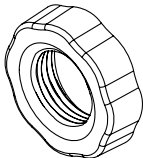
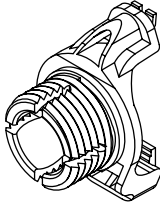

If none of these recommendations or answers fix the problem then please contact your authorised local Tyredog Dealer / Distributor.

Product package content

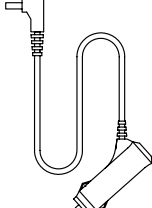
Monitor

Items	Content	Quantity
TD-2300A-X LCD Monitor		1 piece
AA 1.5V battery		2 pieces
User guide		1 piece
Suction cup bracket holder		1 set
Fixed lock ring		1 piece
Holder arm base		1 piece
Monitor holder		1 piece
Cigarette power cord		1 piece

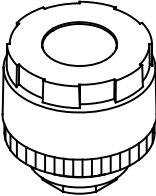
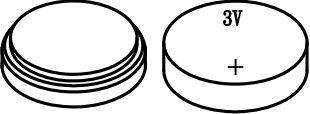
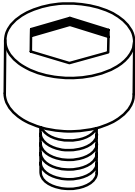
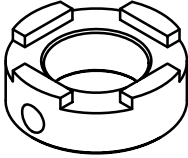
Relay kit

Item	Item photo	Type					
		X04	X06	X08	X10	X12	Unit
Relay		1	1	1	1	1	set
TD-SN2300A-X Sensors		4	6	8	10	12	piece
CR 1632 battery for sensors		4	6	8	10	12	piece
Hex socket screw		4	6	8	10	12	piece
SecureFit Ring		4	6	8	10	12	piece
Allen Key		1	1	1	1	1	piece
AA 1.5V battery for relay		4	4	4	4	4	piece

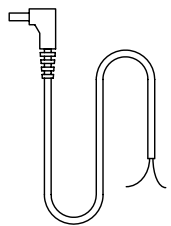
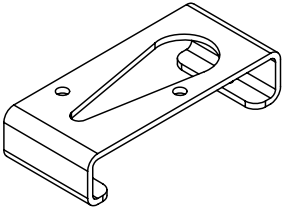
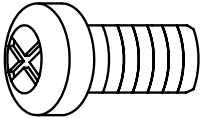
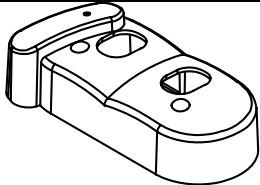
Relay hardwire harness		1	1	1	1	1	1	piece
Relay Mounting Bracket		1	1	1	1	1	1	piece
4mm screw		2	2	2	2	2	2	piece
Relay Cover		1	1	1	1	1	1	piece

Optional Accessories

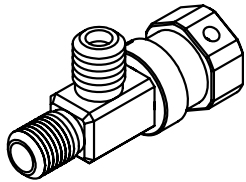
3 way adaptor		4	6	8	10	12	Set
---------------	---	---	---	---	----	----	-----

Product specification

Sensor Specifications	
Frequency	433.92MHz
Pressure range	0-180 PSI
Accuracy	Pressure : ± 3 PSI, Temp : ± 2 Degrees Celsius
Operating voltage	3 Volts DC (Lithium CR1632 3V)
Operating temperature	-40~125 Degrees Celsius
Operating humidity	100%
Battery life	6 or up to 12 Months (Depending on operation time)
Dimensions	20.5mm Diameter X 20mm Height
Weight	10 g (± 1)
Relay Specifications	
Frequency	433.92MHz
Operating Voltage	12V DC / 24V DC
Battery life	6 or up to 12 Months (Depending on operation time)
Operating temperature	-40~85 Degrees Celsius
Operating humidity	100%
Dimensions	105mm (L) X 50mm (W) X 85mm (H)
Weight	200g

Specifications are correct at time of publication. Subject to change without notice.

Monitor Specifications	
Frequency	433.92MHz
Operating voltage	12 / 24V DC Only (External)
Operating temperature	-20~70 Degrees Celsius
Dimensions	102mm (L) X 72mm (W) X 29mm (H)
Weight	143 g

Specifications are correct at time of publication. Subject to change without notice.

1 Year Warranty

Zylux Distribution Pty. Ltd. warrants to the Customer that this product is substantially free from defects in materials and workmanship under normal use for a period of 1 Year from the Date of Purchase (Excl. Batteries) when Purchased through an Australian / New Zealand Authorised Dealer / Retailer.

Please ensure you keep a copy of your receipt on file as this will be required for proof of purchase and to validate your warranty.

Obtaining Warranty Service

Within the warranty period, the Customer must contact the authorised Dealer / Retailer where the product was purchased or alternatively you can contact the Zylux (Tyredog) service centre through one of the following methods:

Hotline: (03) 9482 2203

Website: www.tyredog.com.au

If the Authorised Supplier and / or Zylux (Tyredog) service centre concludes that while under normal use, a product failure or malfunction occurred during the warranty period and was caused by a defect in material or workmanship (see Exclusions), the Customer will be asked to ship to the nearest service point. The product must be packaged appropriately for safe shipment. To prove that the product is under warranty, the customer should enclose a copy of their receipt for proof of purchase. It is recommended that returned products be sent by registered mail as Zylux Distribution Pty Ltd. accepts no responsibility / liability for goods lost or damaged in transit. Return Shipping costs to be incurred by the Customer.

1 Year Warranty Continued..

Repairing / Replacing Faulty Products under Warranty

Products presented for repair may be replaced by refurbished products of the same type rather than being repaired. Refurbished parts may be used to repair the products.

Replacement of the product or a part does not extend or restart the Warranty Term.

Warranty Exclusions

If upon receiving a product for repair and if testing and examining the product has disclosed that the alleged defect or malfunction in the product does not exist or was caused by the Customer or any third persons misuse, physical abuse, water damage, unauthorised attempts to open, repair or modify the product or improper installation, this will not be covered under this warranty.

This Warranty is void if:

1. The product has been tampered or repaired by unauthorised personnel.
2. The warranty seal is broken or altered.
3. The warranty period has expired.
4. If Purchased via Ebay, Overseas or a non approved Dealer / Supplier.
5. Reverse Polarity power or Battery connection.

For further information regarding Warranty Obligations and Rights, you can check with your local Government Authority.



Truck & Trailer
TYREDOGTM
TD-2300A-X Series



Zylux Distribution Pty. Ltd. (Australia)
Website: www.tyredog.com.au