

AUTOMOBILE

TYREDOG™

WIRELESS TIRE PRESSURE MONITORING SYSTEM

TD1300A-X v1.1

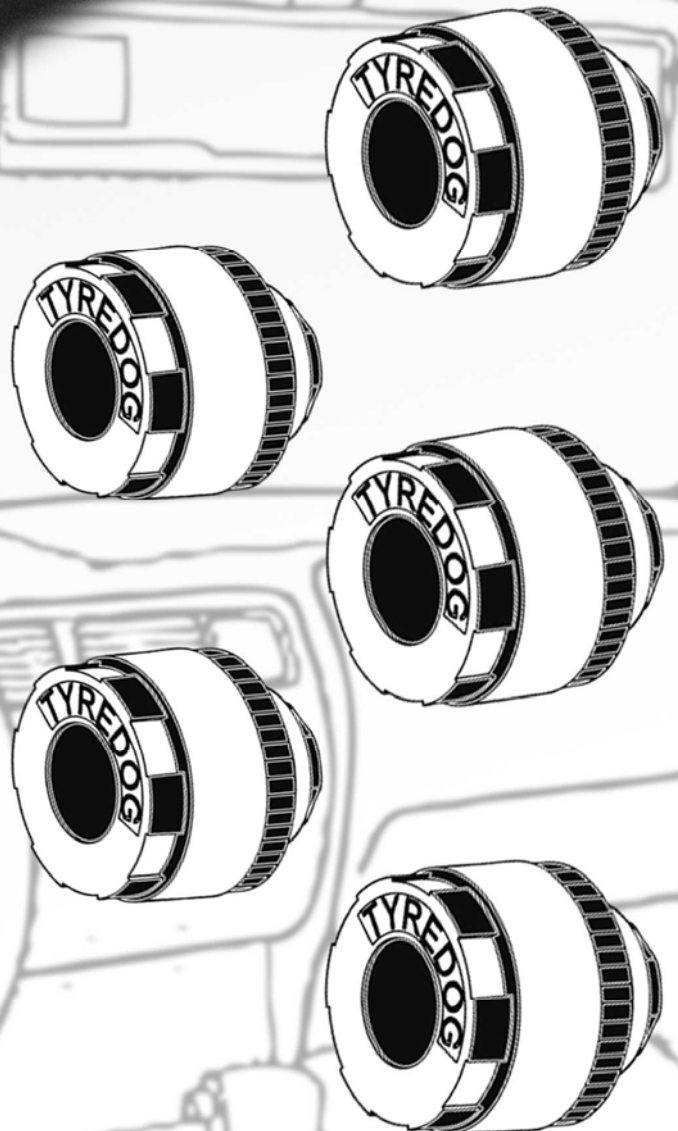
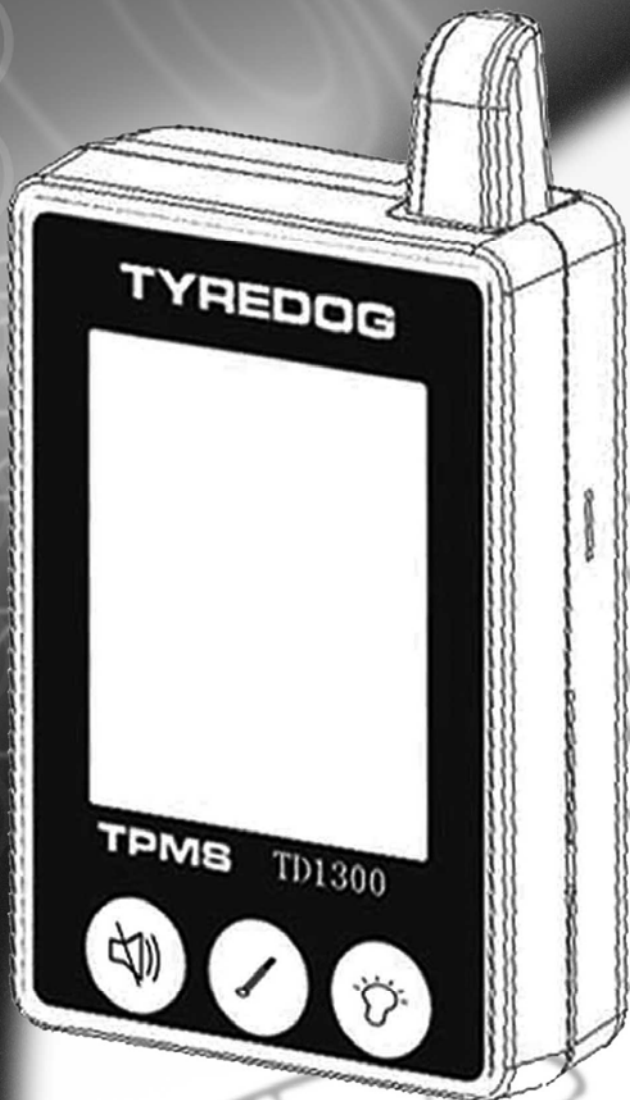

IMPORTANT INFORMATION	3
TPMS ADVANTAGES	4
EXCLUSIVE FEATURES	5
INSTALLATION	5
OPERATION	6
DESIGN	6
TYRE PRESSURE & SAFETY INFORMATION	7
PACKAGE CONTENTS / PARTS CHECKLIST	8
SYSTEM COMPONENTS	10
GUI LAYOUT	12
INSTALLATION	13
MONITOR	13
SENSORS	14
MOUNTING BRACKET	16
OPERATION	17
MAIN BUTTON LOCATIONS	17
MAIN BUTTON FUNCTIONS	18
SETTING WARNINGS	19
SENSOR LEARN MODE	20
SLEEP MODE	21

WARNINGS	22
LOW PRESSURE WARNING	22
HIGH PRESSURE WARNING	23
HIGH TEMPERATURE WARNING	24
LOW BATTERY WARNING	25
BATTERY INFORMATION	26
TROUBLESHOOTING	27
SPECIFICATIONS	28
REFERENCE CHART	29
NOTES	30

IMPORTANT INFORMATION

- This product is designed to indicate the conditions of the air inside your vehicle's tyres. It should not be considered as a device that will prevent any traffic accident, injury or death.
- Tyres and valve stems must be checked before installation. It is very common for rubber valve stems to require replacement without showing signs of wear.
- Never overload your vehicle. Overloading is extremely dangerous and can cause failure of tyres, suspension and driveline components. A vehicle should never be operated if the GVM is greater than the design specification. Even a correctly inflated tyre can fail when overloaded.
- It is the driver's responsibility to ensure safe driving conditions are met before setting off on any trip or journey.

TPMS Advantages

A Tyre Pressure Monitoring System (TPMS) is an efficient and effective solution to many current automotive safety issues. TPMS will help minimize driving risks and reduce fuel consumption. Some benefits include:

- Ensures safe driving conditions.

Tyre pressures can alter ride comfort and handling response.

- Minimises chances of tyre blowout.

Blowouts are a growing cause of road accidents. Even if a car can recover from a blowout, the damaged tyre left behind is an even greater hazard.

- Reduces time taken to inspect tyres.

It can be very time consuming to walk around large vehicles to inspect each tyre. A TPMS will help pinpoint a faulty tyre to save time. Everybody from driving enthusiasts, to small business owners, even nation-wide fleet operators can benefit from the time saved by a TPMS.

- Reduces running costs.

A properly inflated tyre ensures maximum fuel efficiency in all driving conditions. When a tyre is underinflated, it causes more rolling resistance, significantly increasing fuel consumption and engine and transmission wear.

- Extends tyre life

Tyres can be an expensive necessity especially in trucks or sports cars. An underinflated tyre wears quicker meaning it needs replacing sooner.

Exclusive Features

TYREDOG is a powerful tool for maximizing uptime and improving safety. TYREDOG sets a new standard in wireless tyre pressure monitoring systems.

A leading wireless TPMS solution for the light to heavy-duty car and trucking industries, TYREDOG is continuously developing new and better TPMS designs and manufacturing technologies. TYREDOG has helped major players in the trucking industry improve safety and reduce operational costs. The major feature of TYREDOG TPMS is the use of the world's smallest valve cap sensor. The extremely lightweight, compact sensor has been designed to simplify installation and remove the need to have wheels balanced when fitted. Through wireless technology, tyre pressure and temperature information is displayed on the friendly Graphic User Interface (LCD monitor).

Installation

- **D.I.Y:** System can be fitted quickly without any technical knowledge.
- **Wireless:** All signals are sent via radio frequency with no wires.
- **Battery powered:** Sensors and monitor are battery powered, and monitor can be operated with supplied cigarette lighter adaptor.
- **Security:** All kits include the SecureFit locking mechanism meaning your sensors will not come loose unexpectedly.

Operation

- **Real-time:** Tyre pressures are updated automatically so there is no need to push buttons to check up on your tyres (except temperature).
- **Graphical user interface (GUI):** All information is displayed together so unlike other systems, there is no need to scroll through each wheel to view status.
- **Adjustable:** High and low warning alarms offer great flexibility.
- **Audible:** You can't be expected to always keep watch of your tyres, so a built in alarm will sound when there is a sudden change in pressure or temperature, giving you peace of mind.



Design





- All sensors can be securely locked onto tyre valves for added safety.
- Learnable sensors are available so in the event of theft or damage, sensors can be quickly and easily replaced.
- Sensors have unique individual codes to ensure there is no interference from other 433MHz devices, even other TYREDOG systems.
- All TYREDOG kits undergo strict field testing to ensure quality.
- The TD1300A-X can monitor tyres with pressures up to 60psi so almost all car/4wd applications are supported.
- Sensors are treated for anti-corrosion during manufacture and use rubber seals to prevent liquid and fine particles from coming in contact with the circuitry.

Tyre Pressure & Safety Information.

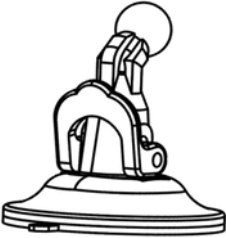
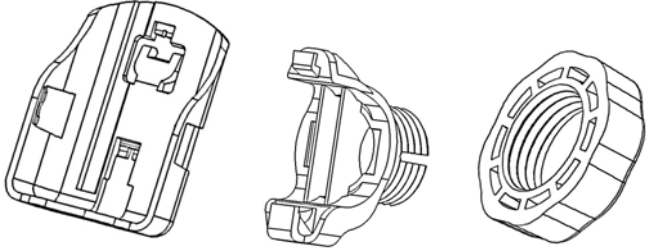
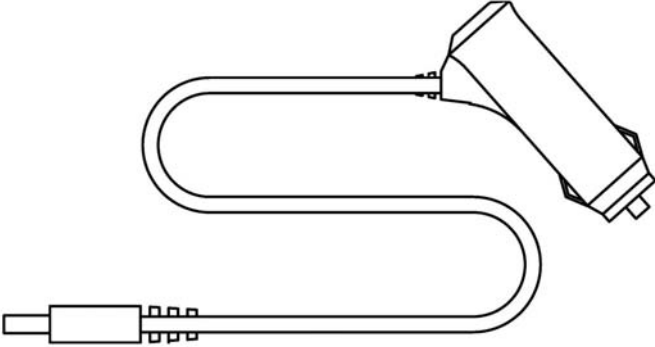
- Please take the time to choose a suitable location so operation can be performed quickly and safely.
 - Be sure that the LCD monitor is firmly fixed to the windshield or dashboard using the supplied mounting hardware.
 - Please practice safe driving and only take the time necessary to read the information displayed on the screen.
- Ensure the sensors communicate with the LCD monitor before initially fitting them to your tyres to save time and hassle.
- Tyredog TPMS has a unique SecureFit mechanism to prevent sensors from coming loose. You can decide whether to install it or not.
- Regularly check if sensors are fitted tightly. If necessary, spread water with detergent on the valve stem to see if your valves are leaking.
- If a rapid deflation warning sounds, stop the car immediately to check the tyre for damage. Remember to be safe when pulling over.
- The monitor will automatically make connections when it is powered on. It is normal for some readings to freeze until sensor updates are received.
- All Tyredog sensors have their own unique codes and are designed to reject interference from other devices operating on the same frequency.
- Many factors can cause tyre pressure to rise and fall. For example, warm weather or long distance trips will lead to a rise in tyre pressure.
- It is normal for tyre pressure to decrease over long periods of time. Periodically re-inflate tyres especially if your car is not regularly driven.
- If you have any questions or problems concerning your unit that are not covered in this manual, please consult your nearest Tyredog dealer.

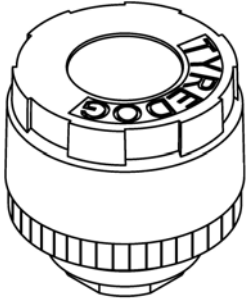
Package Contents / Parts Checklist

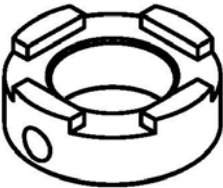
Item	QTY	
LCD Monitor		ONE
User Guide		ONE
AAA Battery (LR03)		TWO
Bracket Base		ONE
Bracket base.		ONE SET
Cigarette lighter adapter.		ONE

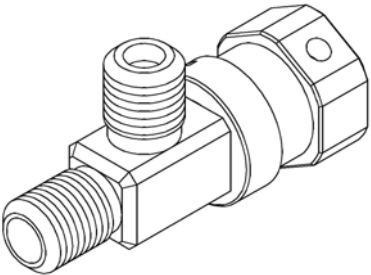
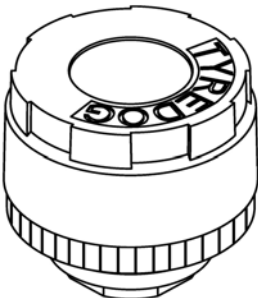
Tyredog Sensor		FIVE
CR1632 Lithium Battery		FIVE
SecureFit fixing ring		FIVE
Hex screw		FIVE
Allen Key		ONE
Optional Accessories		
3-way adapter set supplied with fixing screws.		<p>The 3-way adapter is sold individually and only available from an authorized TYREDOG re-seller.</p> <p><i>(RECCOMENDED ONLY FOR DEEP DISH OR TRUCK WHEELS)</i></p>
Replacement learnable sensor. <i>Must be ordered as specific wheel replacements only.</i>		Replacement sensors are sold individually and only available from an authorized TYREDOG re-seller. Supplied with SecureFit fixing ring.

System Components

Monitor

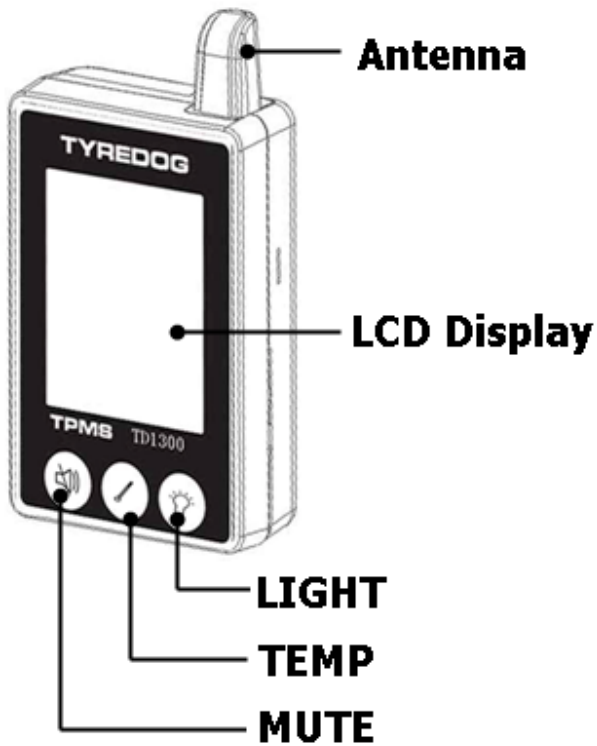

Front of Monitor

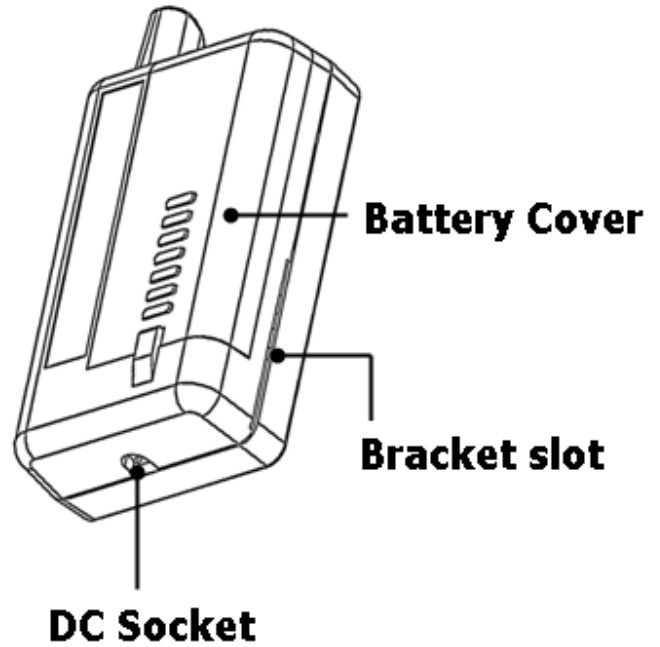

Back of Monitor

Mounting Bracket

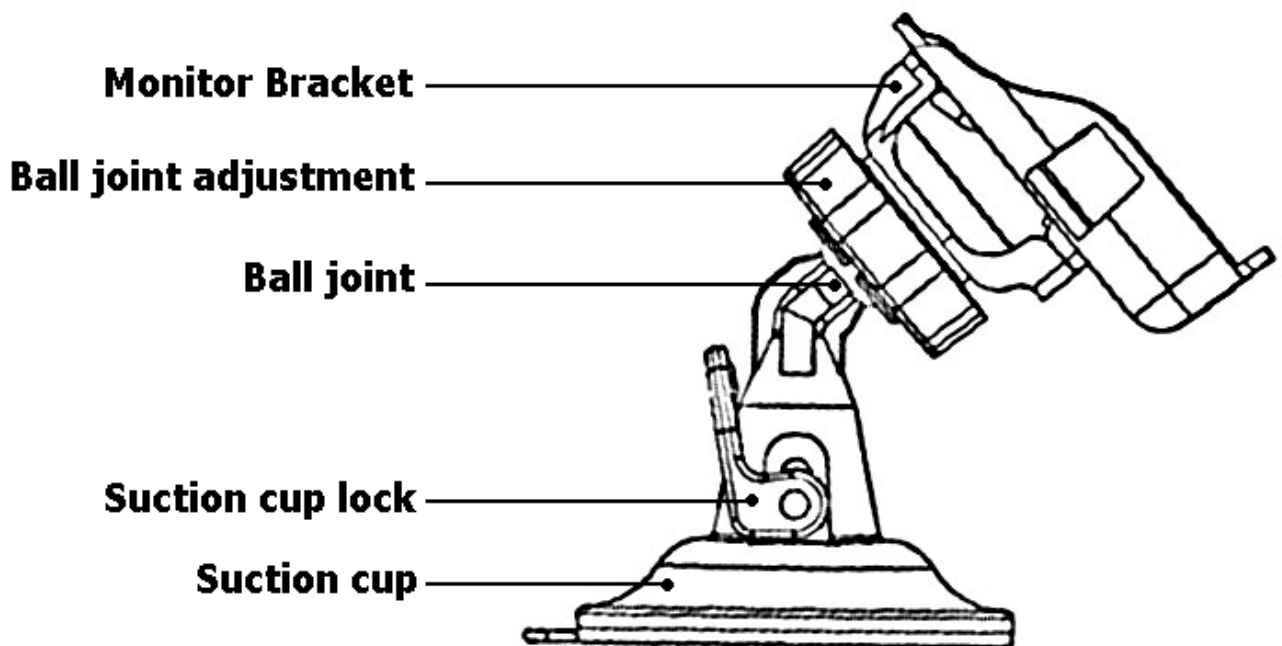

Tyredog Sensor

The sensor has two sections: The sensor cap and sensor body. Its lightweight design and external application is intended to aid the user to install tyre pressure system at home without any technical knowledge or assistance.

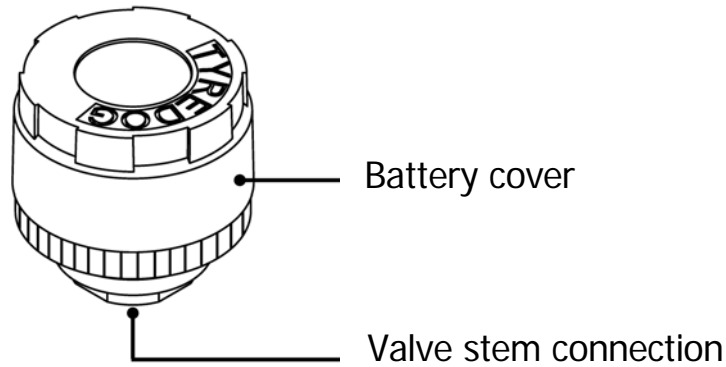

3-way adapter

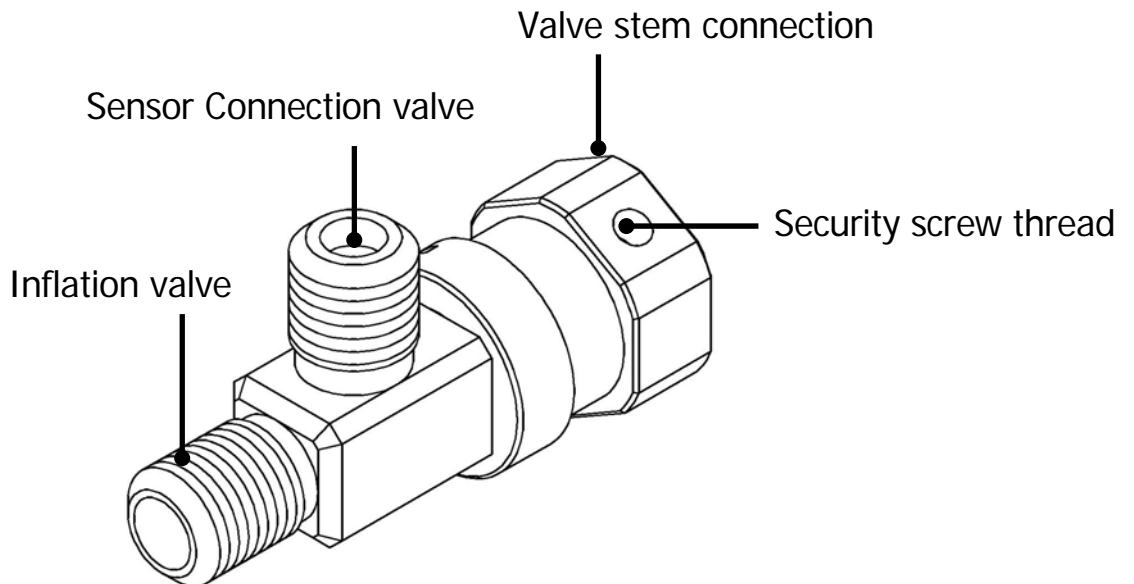

The 3-way adapter is an optional accessory and must be purchased separately.

(RECOMMENDED ONLY FOR DEEP DISH OR TRUCK WHEELS)

GUI Layout

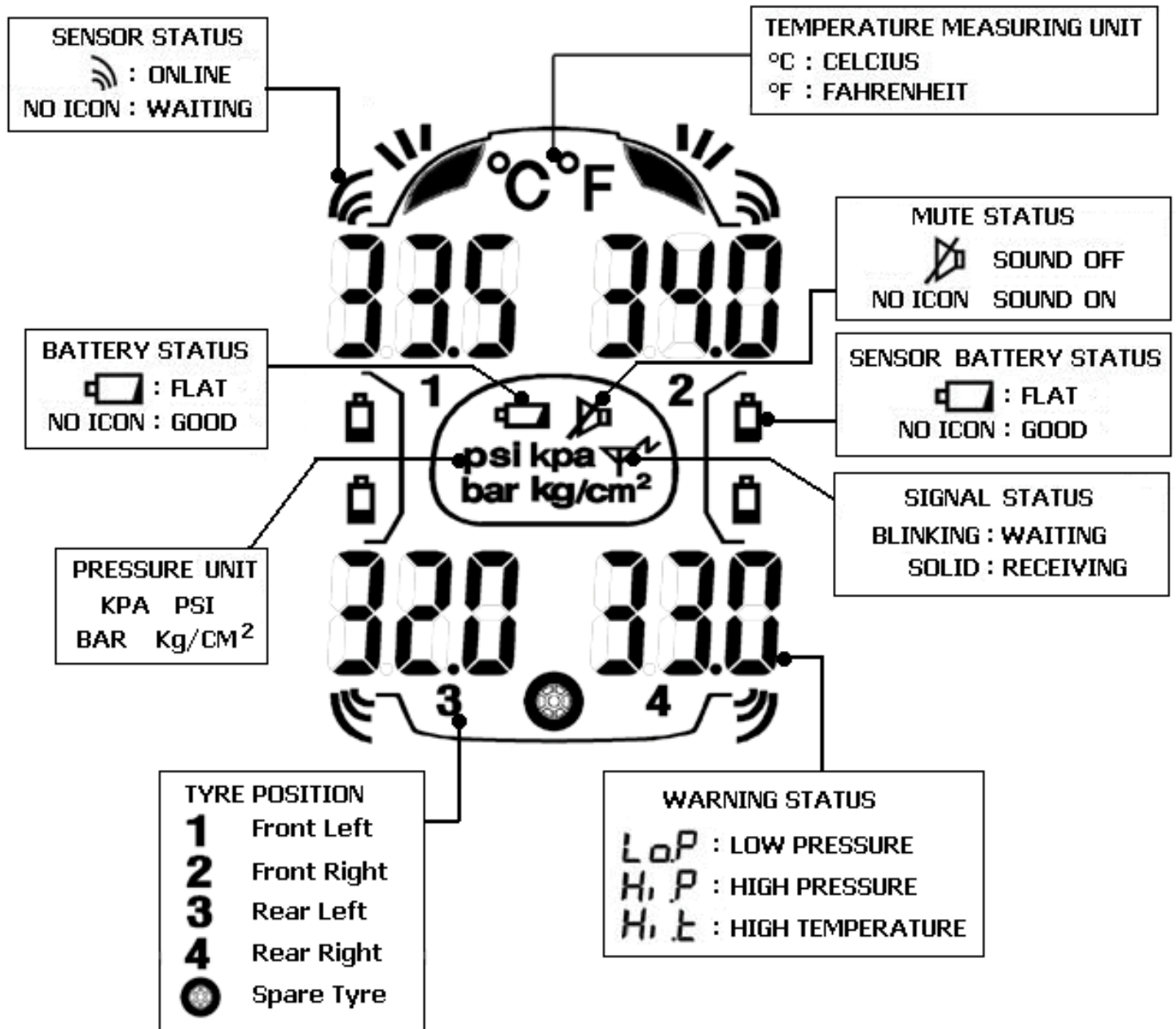

Installation

The LCD monitor can be powered by 2x AAA batteries, or your car's power by using the supplied cigarette lighter adapter. Please follow the steps below outlining how to install batteries into the monitor and sensors and powering up the system for the first time.

Using your thumb, slide the battery cover toward the top of the monitor.

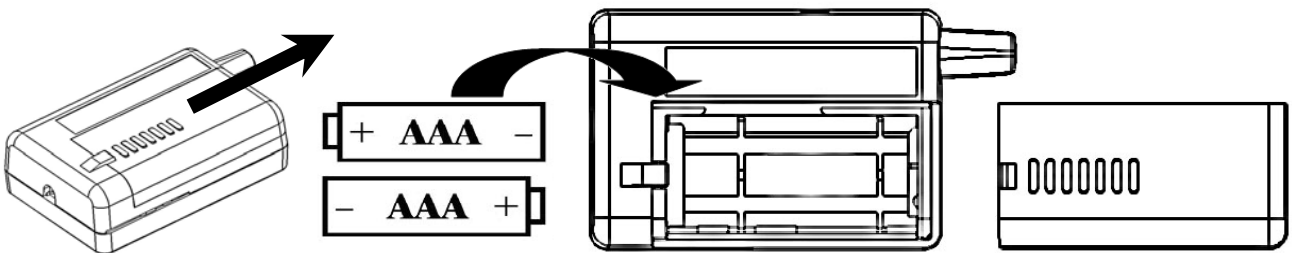

Insert the negative end of the battery onto to the spring side of the battery holder and push the other end in until it locks in place. Be sure the battery polarity is correct and replace the cover. The polarity is also marked inside the battery area. When the batteries are inserted correctly, the monitor will power up, and the home screen will be displayed within a few seconds.

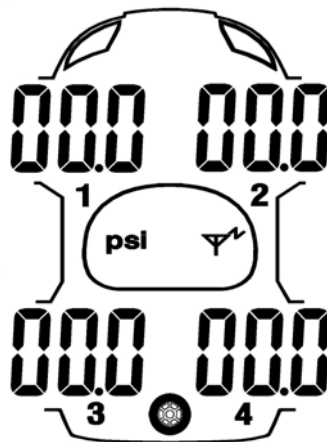

The home screen will be shown like this for the first time until sensors are online and/or reading pressure.

Remove the sensor cap and insert the battery like shown.

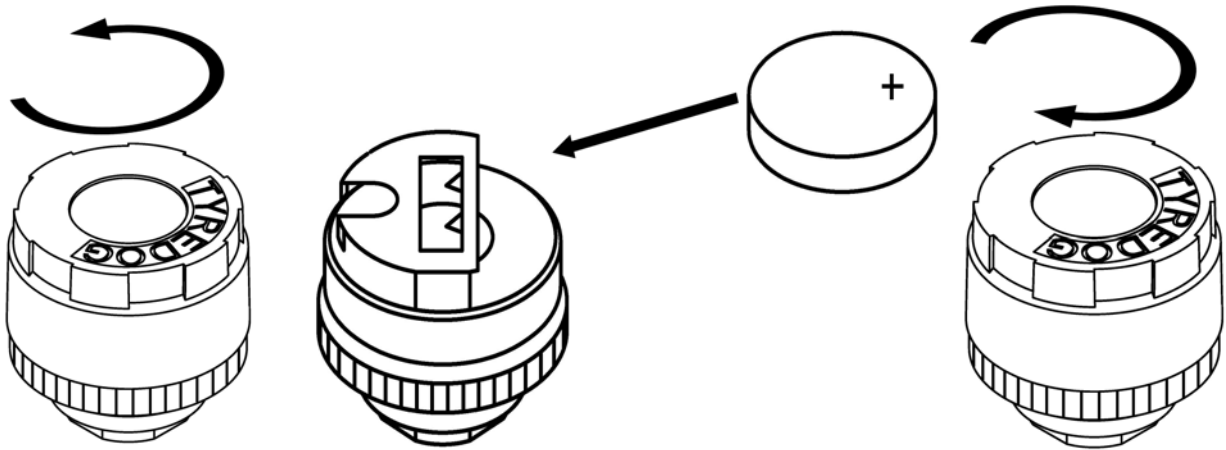

The LCD monitor will beep, and the corresponding display for that sensor flash, alternating between 'Lo.P' and '00.0'.

Replace the battery cover and ensure it is screwed on tight.

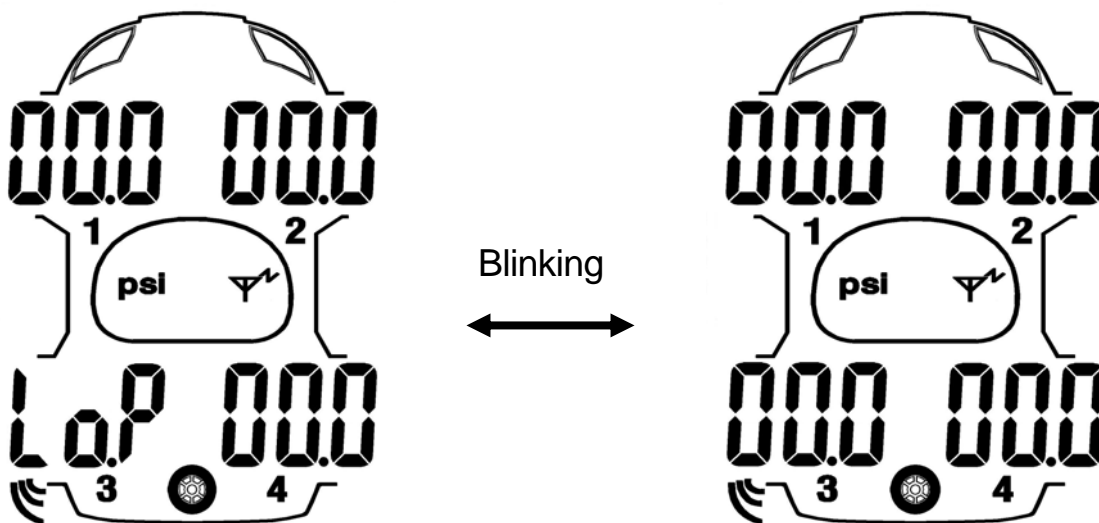

EG: Sensor RL is online, but no pressure is detected.

This is indicating that the sensor is online, but not yet mounted. Repeat this process with the remaining sensors until all sensors are online. If any sensors fail to come online, please try a battery from another working sensor, or consult your nearest Tyredog dealer. Once all sensors are online, proceed to fitting the sensors to your tyre valves.

Visually inspect your tyre's valves for any damage or defect before fitting to ensure further damage does not occur. If you do notice that something is not right with your valves, have them checked by a tyre professional.

1. After removing the original valve caps, slide the SecureFit fixing ring over the valve stem with the flat surface towards the wheel.
2. Screw the Tyredog sensor on in a clockwise direction until you feel the valve stem come under pressure.
3. Slide the SecureFit fixing ring back up to the base of the sensor and line up the grooves. Once locked into place, tighten the hex screw with the supplied Allen key.

If you do not wish to use the SecureFit fixing ring, only follow step 2.

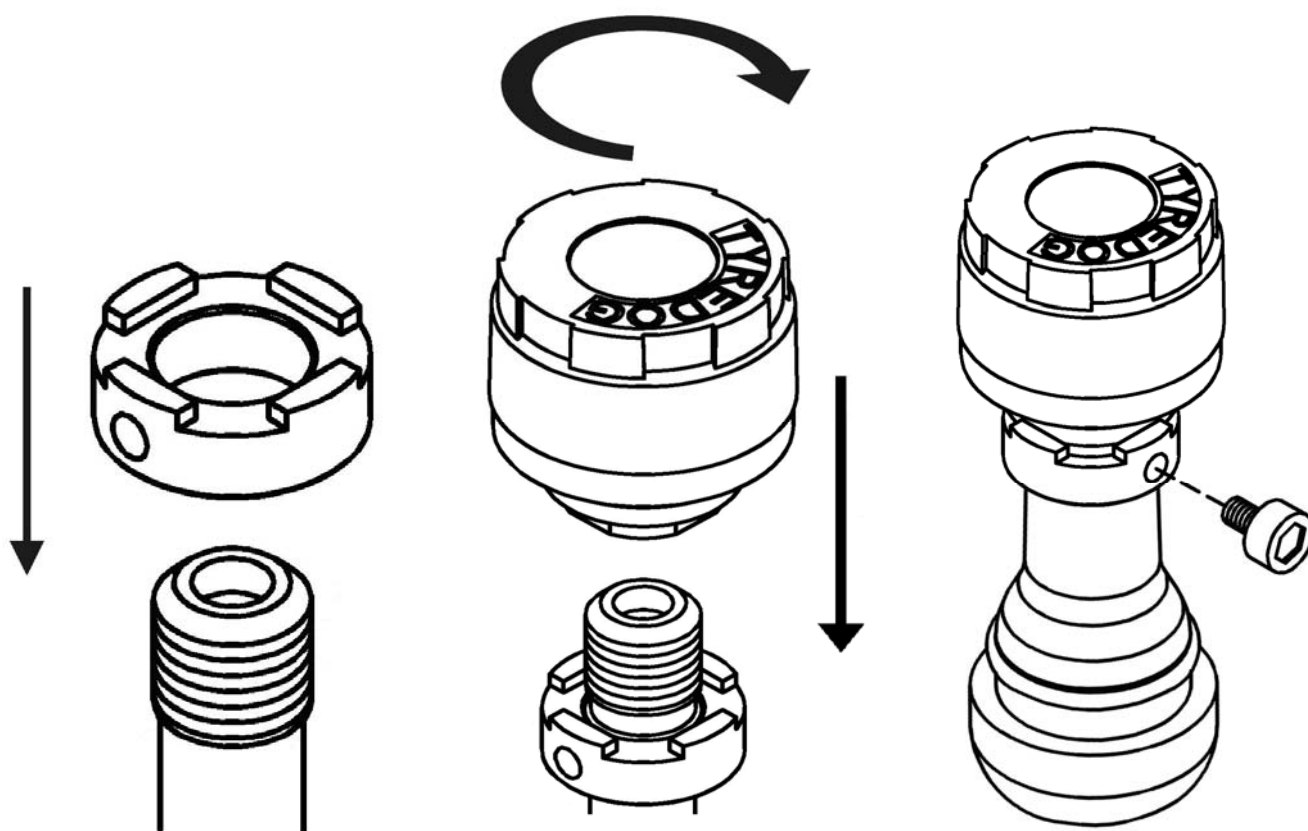

As each sensor is fitted to the respective tyres, the monitor will display the pressure for that sensor. It is normal for the monitor to warn of high or low pressure upon initialisation because the warning thresholds are yet to be set. If a pressure fails to be shown on screen, try the sensor on a different tyre to ensure there is not fault with the valve.

Assembling the mounting bracket

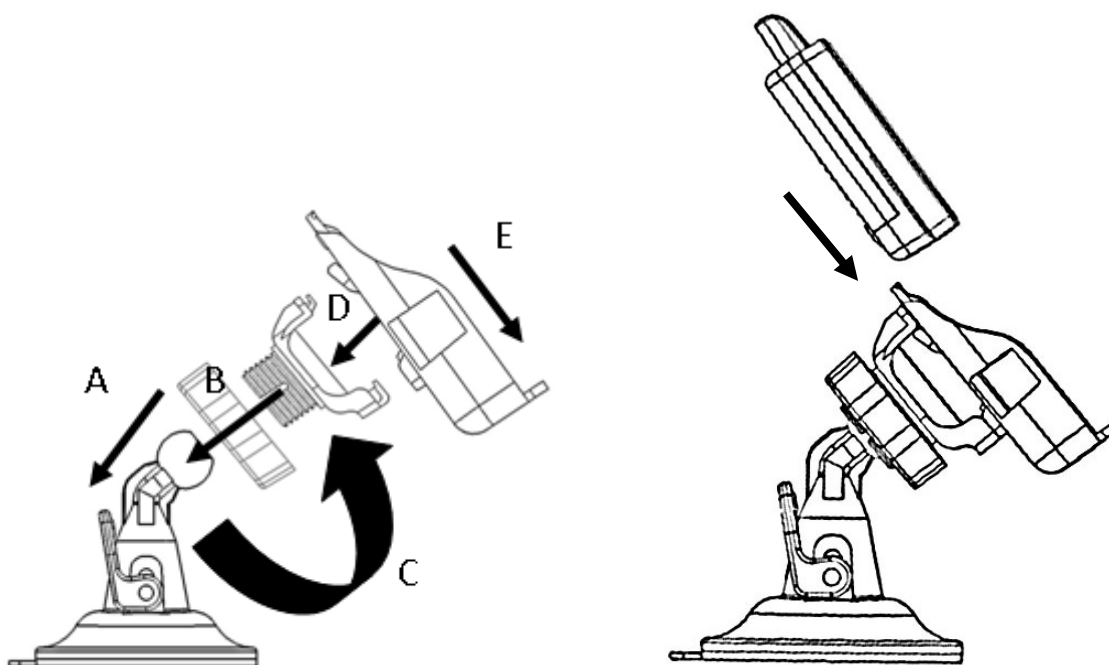

Screw the monitor arm to the base you have chosen making sure the ball joint is seated correctly in the socket.

Hook the bracket into the slot at the rear of the unit and tighten the screw.

Adjustments can be made by using the angle adjustment and the pivoting ball joint on the mounting base.

Operation

Main button locations

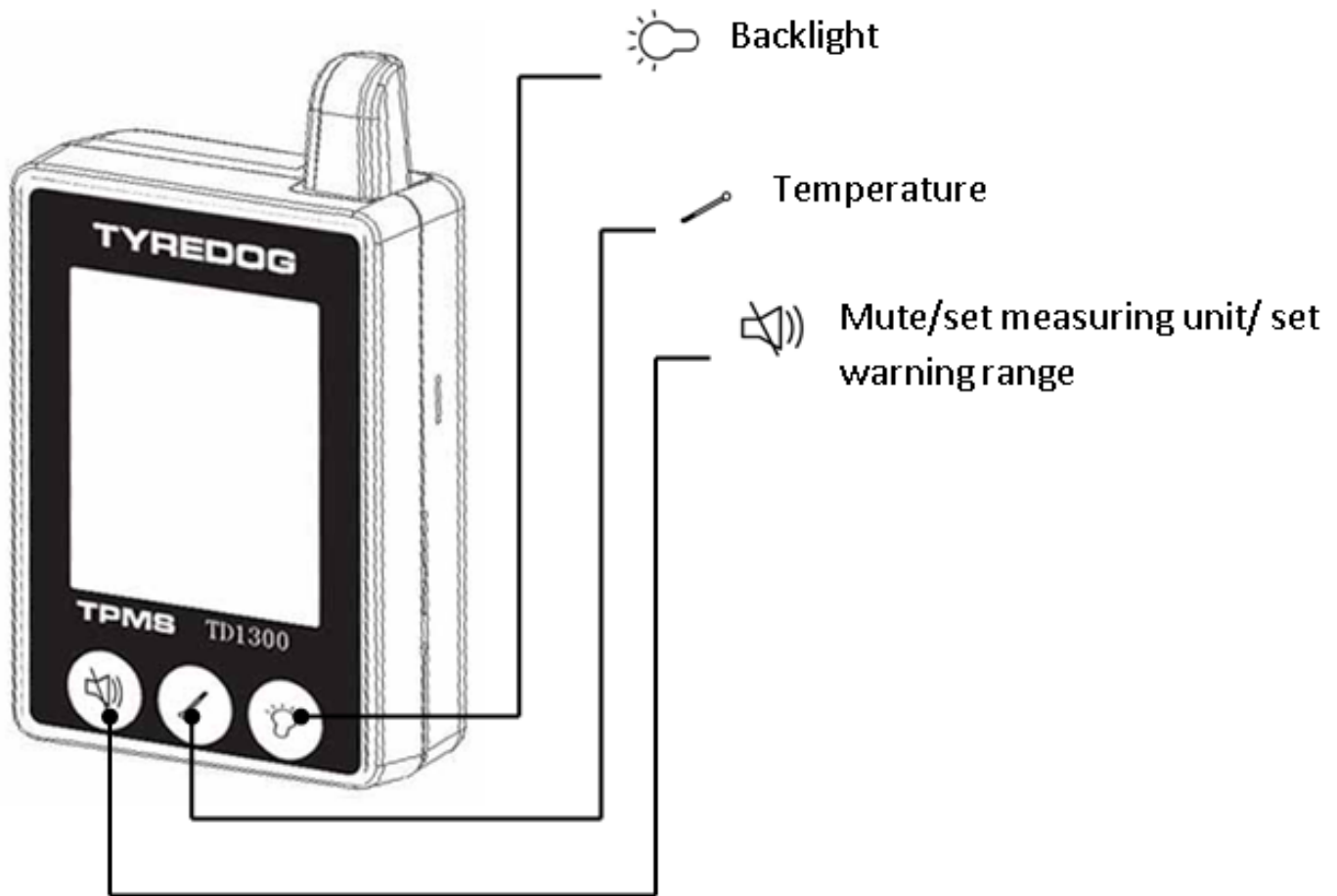





Important Note:

The TD-1300A does not have a power switch.

The internal vibration sensor is equipped with a 15 minute timer that controls when the unit is powered on/off.

This is a design intention to aid the compact and convenient design.

Main button functions

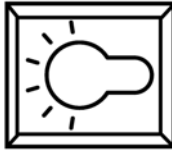
	<p>Mute</p>	<p>Holding the MUTE button for 4 seconds will mute audible warnings. This is indicated by the speaker icon with a strike through it on the GUI.</p>
<div style="text-align: center;">  </div> <p style="text-align: center;">When muted, button press beeps are still active.</p>		
	<p>Temp</p>	<p>Pressing the temperature button will illuminate the display and show all temperatures for 5 seconds. After 5 seconds, the Spare Tyre status will be shown. Temperature is shown in the FR area and pressure in RR.</p>
<div style="display: flex; justify-content: space-around; align-items: center;"> <div style="text-align: center;">  </div> <div style="text-align: center;">  </div> </div>		
	<p>Light</p>	<p>When on battery power, pressing the backlight button will illuminate the screen for 5 seconds. Note: The screen is constantly illuminated when operating on cigarette lighter power.</p>

Setting Warnings

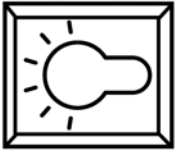
	<p>Light</p>	<p>Holding the Light button for 4 seconds will enable the settings menu. The settings menu has 11 sub-levels which are shown below.</p>
--	--------------	---

The Temperature and Mute buttons are used to adjust the setting values.

Press LIGHT again to advance through each of the remaining 10 settings.

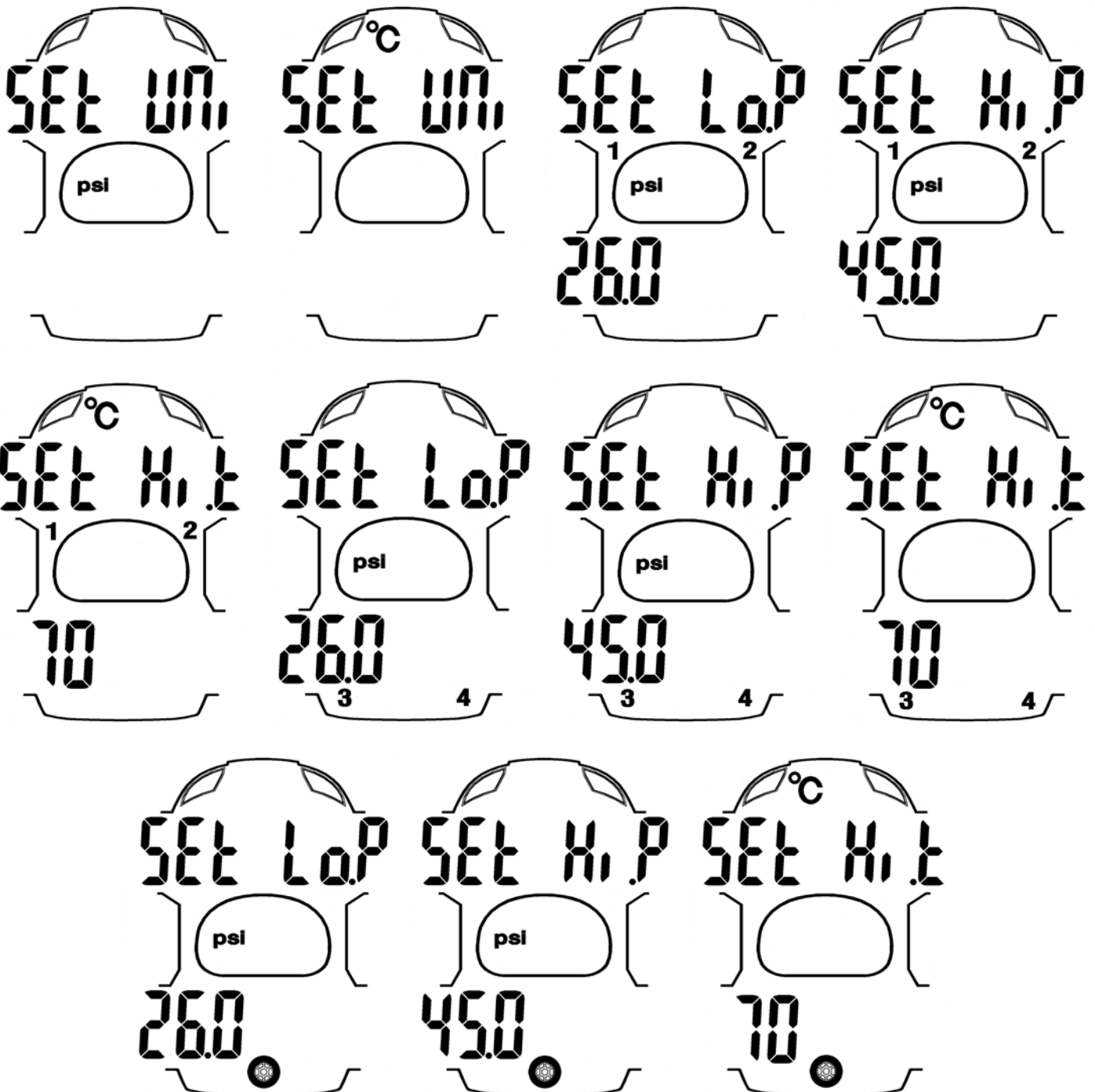

Warning values can be set for each axle and the spare tyre separately.

When setting each warning value, the corresponding axle will flash with the value being adjusted (1+2, 3+4, Spare)

When Light is pressed after the last setting, the home screen will be shown.

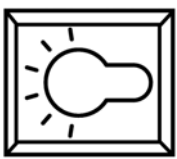

+

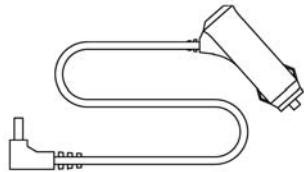

Replacement Sensor Learn Mode

If in any case a sensor is lost, stolen or damaged, it can be replaced with a 'Learnable Sensor.' These sensors have their own special code and can only replace those of the same type and wheel location. For example, if sensor FR is damaged, it can only be replaced by a 'FR Learnable sensor.' Learnable sensors can be purchased individually at an authorized Tyredog reseller.

To enter learn mode, provide power to the monitor while holding the LIGHT button. Continue holding the LIGHT button until 'LEN' is shown in the four corners of the screen. You must continue holding the LIGHT button until 'LEN' is displayed or Learn Mode will not be initiated.

Once the system is in learning mode, you can proceed to program your new learnable sensors. Simply insert the battery into the learnable sensor to activate its code in the monitor's memory. When the code is learnt, the monitor will beep once, and the new code will be displayed in the corresponding wheel location on the display as shown in the following image. To avoid programming confusion, ensure there are no existing sensors with batteries fitted at the time.

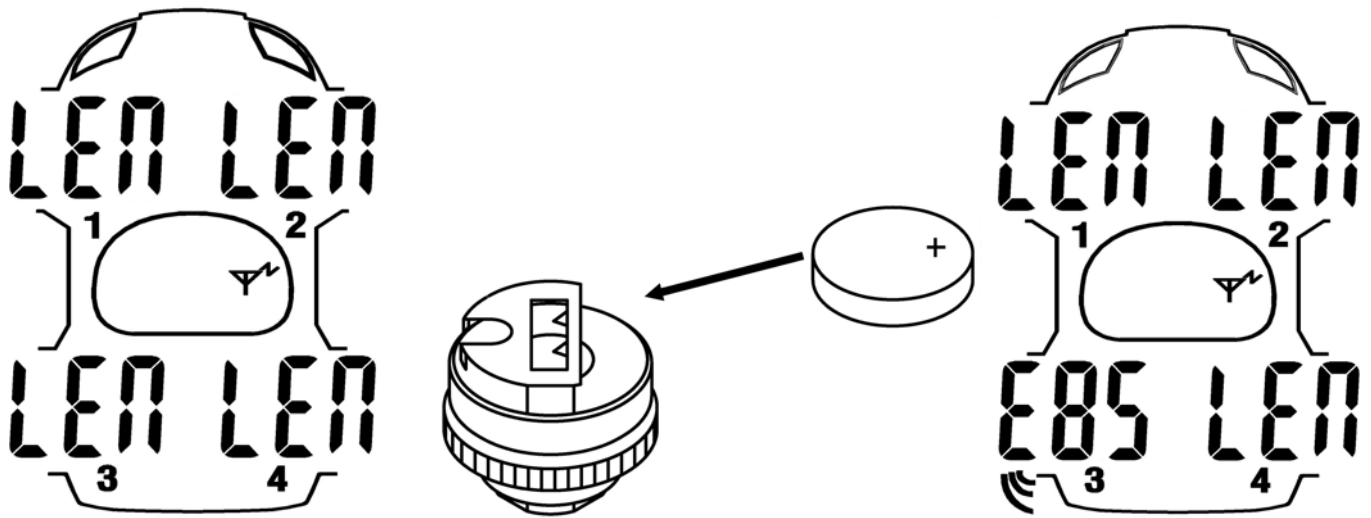

If a battery is inserted to a non learnable existing sensor whilst the monitor is in learning mode, the monitor will beep 3 times to indicate that it's not a learnable code. If you hear 3 beeps with your learnable sensor, please contact your reseller to obtain a replacement.

Note: it is normal for sensors to take some time to initiate. If no beeps are heard when the battery is inserted, wait a few moments.

Sleep Mode

As previously mentioned on page 17, the Tyredog monitor has a built in vibration sensor which is used to switch power. If the unit is left still for 15 minutes, it will automatically turn off. This also eliminates the need for a power switch, which helps minimize the size of the monitor. If the monitor receives any vibration or a button is pressed, it will automatically power up to its previous state.

Warnings

Low Pressure Warning

If a tyre's pressure drops below the low pressure threshold, the monitor will beep three times and back light will illuminate for four seconds. The corresponding sensor location will alternate between the current pressure and "Lo.P." The monitor will continue to beep 3 times for every 1 PSI the pressure drops until the problem is rectified. If the pressure drops rapidly, the monitor will beep 10 times.

The picture below indicates that the rear-left tyre has low pressure.

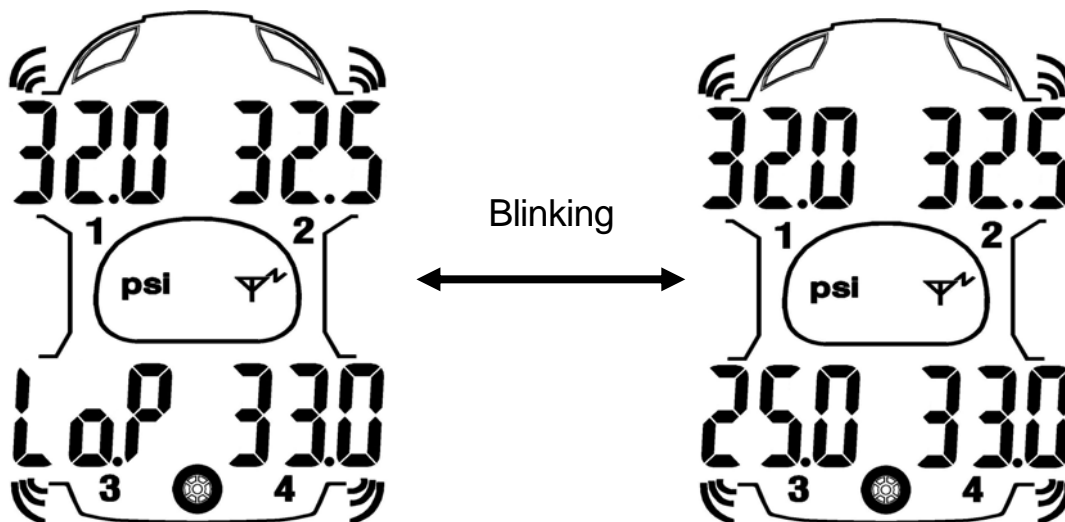

High Pressure Warning

If a tyre's pressure rises above the high pressure threshold, the monitor will beep three times and back light will illuminate for four seconds. The corresponding sensor location will alternate between the current pressure and "Hi.P." The monitor will continue to beep 3 times for every 1 PSI the pressure rises until the problem is rectified. If the pressure rises rapidly, the monitor will beep 10 times.

The picture below indicates that the rear-left tyre has high pressure.

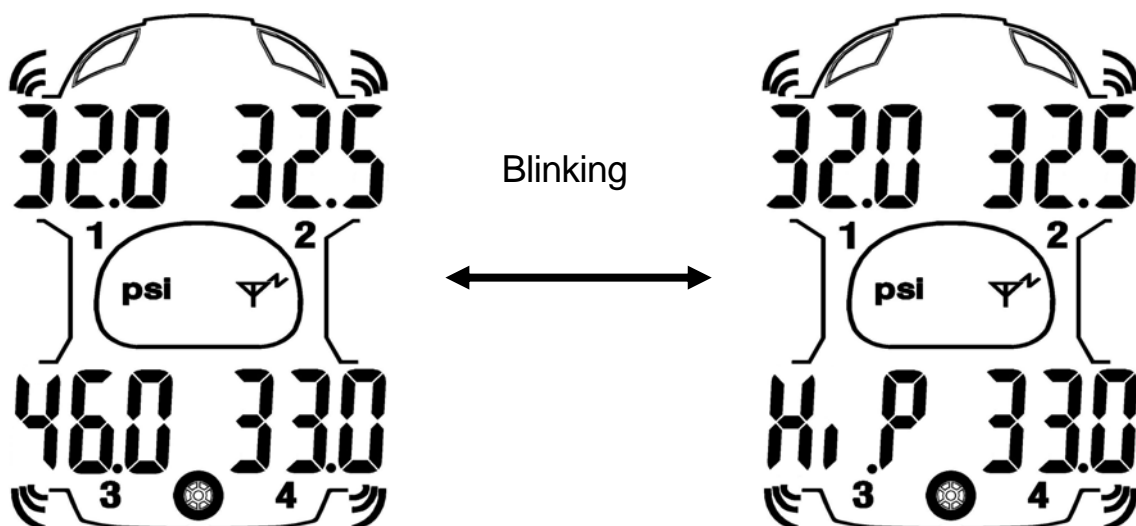

High Temperature Warning

If a tyre's temperature rises above the high temperature threshold, the monitor will beep three times and back light will illuminate for four seconds. The corresponding sensor location will alternate between the current pressure and "Hi.t." The monitor will continue to beep 3 times for every 1 degree the temperature rises until the problem is rectified.

The picture below indicates that the rear-left tyre has high temperature.

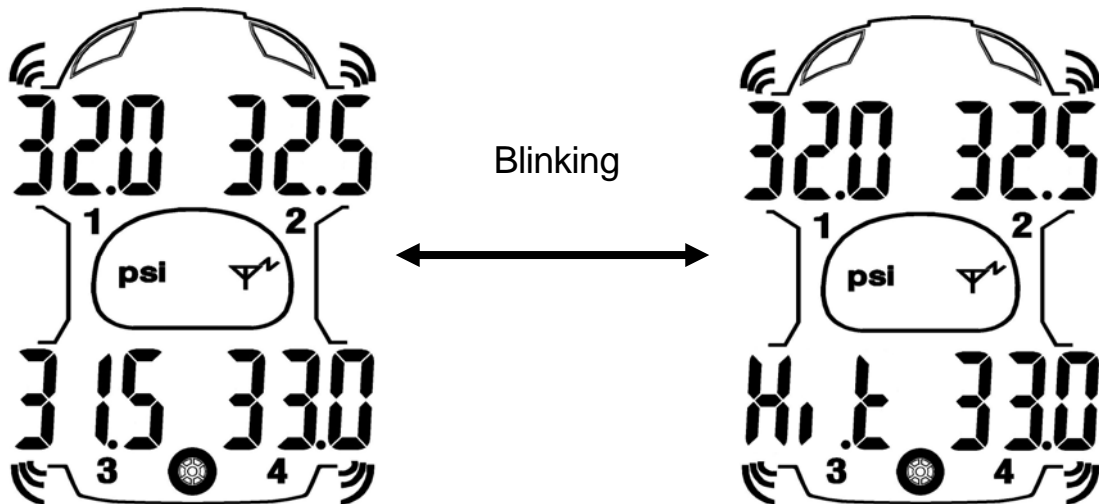

Low Battery Warning

With daily use, the battery level will decrease. Usual battery life is expected to be between 6 and 12 months for the sensor.

When the monitor batteries are running low, a horizontal low battery indicator will be displayed in the middle section of the screen. (LEFT)

When a sensor battery is running low, a vertical low battery indicator will be displayed in the corner of the screen respective to the sensor. (RIGHT)

A low battery indicates around 2 weeks left of battery charge is remaining in that particular batter. Please be aware that the system may function improperly when batteries are low.



Low Monitor Battery Indicator



Low Sensor (RL) Battery Indicator

Battery Information

Under normal conditions, sensor batteries will last approximately 12 months. Depending on operation conditions and frequency of use, battery life can be shorter or longer.

Tyredog Sensors use battery type 'CR1632' (3 Volt Lithium Button Cell)
CR1632 batteries are available for purchase from your nearest Tyredog reseller.

Notes on batteries

- Keep lithium batteries out of reach of children.
- Should a battery be swallowed, immediately consult a doctor.
- Wipe the battery with dry cloth to ensure a good contact.
- Always be sure of correct polarity when installing batteries.
- Observe the expiry date on old batteries.
- Batteries may explode if shorted or mistreated.
- Do not charge non-rechargeable batteries.
- Do not attempt to disassemble batteries.
- Never dispose of batteries in fire.

Troubleshooting

If any sensors are failing to give a reading, or you feel an incorrect reading is being given, follow this procedure;

1. Turn the monitor off.
2. Remove batteries from all sensors.
3. Remove all sensors from valves.
4. Turn the monitor back on.
5. Insert batteries into sensors one by one.
6. Fit sensors to valves one by one.

If you feel your system has a fault which cannot be rectified by this procedure, please contact your Tyredog dealer.

Always ensure batteries have enough power before inserting into sensors.

If unsure, use a battery from a known working sensor.

It is normal for the screen to turn dark after extended exposure to sunlight.

Always be aware that heat and extended driving periods can greatly alter tyre pressure and drivability.

Note: Sensors may not always come online straight away when the monitor/receiver is turned on as they require movement / vibration. This may take a few minutes once the wheels begin rotating.

Product specifications

Sensor specification	
Frequency	433.92MHz
Pressure range	0-60 PSI
Accuracy	Pressure: ± 1.5 PSI – Temp: ± 2 Degrees Celsius
Operating voltage	3 Volts DC
Operating temperature	-40~125 Degrees Celsius
Battery life	6 months (depending on daily operation time)
Dimensions	20.5mm Diameter x 20mm Height
Weight	10 g (± 1 g)



















Monitor specification	
Frequency	433.92MHz
Operating voltage	3 Volts DC (Battery) 12 Volts DC (External)
Battery life	6 months (depending on daily operation time)
Operating temperature	-20~80 Degrees Celsius
Dimensions	63mm (L) X 42.5mm (W) X 20mm (H)
Weight	60 g

Specifications are correct at time of publication. Subject to change without notice.

Replacement Parts

Wheel (1) Front Left	- Model no. SN-1000A-X-FL
Wheel (2) Front Right	- Model no. SN-1000A-X-FR
Wheel (3) Rear Left	- Model no. SN-1000A-X-RL
Wheel (4) Rear Right	- Model no. SN-1000A-X-RR
Wheel (5) Spare	- Model no. SN-1300A-X-5

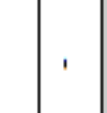
Quick Reference Chart

Model / Application	2 Wheels		4 Wheels		5 Wheels		6 Wheels			8 Wheels		10 Wheels
	 Motorcycle	 Car / 4WD OR  Heavy Duty	 Car / 4WD OR  Car and Trailer or Caravan 	 Light Duty Ute or Van OR 	 Car and Trailer OR 	 Car and Caravan OR 						
TD-4000A-X	✓	-	-	-	-	-	-	-	-	-	-	-
TD-1000A-X	-	✓	-	-	-	-	-	-	-	-	-	-
TD-1300A-X	-	-	✓	-	-	-	-	-	-	-	-	-
TD-2000A-X04-R	-	-	-	✓	-	-	-	-	-	-	-	-
TD-2000A-X06-R	-	-	-	-	✓	-	-	-	-	-	-	-
TD-2000A-X08-R	-	-	-	-	-	-	-	-	✓	-	-	-
TD-2000A-X10-R	-	-	-	-	-	-	-	-	-	-	✓	-

Units with relay/repeater (For use with Car and Trailer/Caravans, Motor Homes, Trucks and Buses)

1 Year Product Warranty

Zylux Distribution Pty. Ltd. warrants to the Customer that this product is substantially free from defects in materials and workmanship under normal use for a period of 1 Year from the Date of Purchase. (Excl. Batteries)

Please ensure you keep a copy of your receipt on file as this will be required for proof of purchase and to validate your warranty.

Obtaining Warranty Service

Within the warranty period, the Customer must contact the authorised supplier / retailer where the product was purchased or alternatively you can contact the Zylux (Tyredog) service centre through one of the following methods:

Hotline: (03) 9482 2203

Website: www.zylux.com.au

If the Authorised Supplier and / or Zylux (Tyredog) service centre concludes that while under normal use, a product failure or malfunction occurred during the warranty period and was caused by a defect in material or workmanship (see Exclusions), the Customer will be asked to ship to the nearest service point. The product must be packaged appropriately for safe shipment. To prove that the product is under warranty, the customer should enclose a copy of their receipt for proof of purchase. It is recommended that returned products be sent by registered mail as Zylux Distribution Pty Ltd. accepts no responsibility / liability for goods lost or damaged in transit. Return Shipping costs to be incurred by the Customer.

Exclusions

If upon receiving a product for repair and if testing and examining the product has disclosed that the alleged defect or malfunction in the product does not exist or was caused by the Customer or any third persons misuse, physical abuse, water damage, unauthorised attempts to open, repair or modify the product or improper installation, this will not be covered under this warranty.

This Warranty is void if:

1. The product has been tampered or repaired by unauthorised personnel.
2. The warranty seal is broken or altered.
3. The warranty period has expired.



Distributed by:

ZYLUX DISTRIBUTION PTY. LTD.
166 Christmas Street, Fairfield, Vic, 3078
Website: www.zylux.com.au
Email: info@zylux.com.au
Tel: (03) 9482 2203