

Instruction Manual

Hi-Flame R4 and R4-LS Compact

Ecodesign Ready / Defra Smoke Exempted
Free-standing Wood Burning Stove

hi-flame

OUTSTANDING ECODESIGN STOVES

www.hi-flame.co.uk

www.hi-flame.ie

Please note that this appliance has been independently CE and DIN+ tested by an EU Notified Laboratory and is approved by Defra as an 'exempted appliance' to allow the burning of wood in designated UK Smoke Control Areas (see page 16). Fully seasoned wood, with less than 20% moisture content, must always be used and the appliance must also be operated at all times in accordance with these instructions to minimise the amount of smoke produced.



IMPORTANT: USER WARNING NOTE

Properly installed, operated and maintained this stove should NOT emit smoke or fumes into the dwelling.

Occasionally fumes from refuelling may occur. However, persistent smoke or fume emission is potentially dangerous and must not be tolerated. If this persists, then the following immediate action should be taken:

- Quickly open the doors and windows to ventilate the room.
- Make sure that the stove door is closed and that the combustion air control is fully open. It may be that the open door or a fully closed control have contributed to the problem. The above actions should then ensure that any remaining fuel will combust as normal and not smoulder to create more unwanted smoke or fumes. However, if smoke and fumes persists then leave the premises and let the fire go out.
- Check for a flueway, connecting flue pipe or chimney blockage and clean out if required.
- Check that the wood logs you have used are fully seasoned with a moisture content of less than 20%. Wet wood will always produce excessive smoke as well as create an acrid smell.
- Do not attempt to relight the fire until the cause of the smoke or fume emission has been identified and corrected. If necessary seek expert advice, preferably from a Hetas installer.

The most common cause of smoke or fume emission is flueway or chimney blockage. For your own safety these should be inspected regularly and must be kept clean at all times. See page 31.

If the CO alarm (which should be fitted at the time of installation) sounds, please follow the advice above.

CONTENTS	Page
Packing List	3
Product Verifications	3
Introduction	4
Installer Safety First	4
Product Fiche	5
ErP Energy Label	6
Technical Data	7
Critical Safe Distances	8
General Dimensions	9
Standard Features	10
Assembling the Stove	11
Installation Regulations	12
Further Information Points	12
Basic Installation Check-list	13
General Installation Guidelines	14 – 15
Clean Air Act / Smoke Control Areas	16
Recommended Fuel	17
Fuels you must always avoid	18
When you first light your stove	18
Essential Safety Advice	19
The better way to burn wood	20
Operating your stove	21 – 23
Some simple tips	24
Removing Ash	24
Trouble-shooting	25 – 30
Routine Checks	30
Stove Maintenance	31 – 33
Using Direct External Air	34
Spillage & Flue Interference Tests	35 – 36
Commissioning	37
Standing Down	38
Hi-Flame Warranty	38
Annual Service	39
Annual Service Record	40 – 41
Notes	42 – 43
Spares Service	Back Cover

PACKING LIST

As soon as you receive your new stove please check that you have a full set of components as set out in the list below. In the unlikely event of a shortage, please report this immediately to the dealer you bought the stove from. Never attempt to operate the stove with missing or damaged components.

Product Information

1 This instruction Booklet

Stove Components

1 Stove with Flue Collar

1 Log Retaining Bar(s)

1 Air Control Operating Tool

R4/ R4-LS PRODUCT VERIFICATIONS

These stove models have been tested to **CE EN13240** standards and has passed the latest **EU Ecodesign 2022** emissions and efficiency requirements.

It is officially recognised and listed in the United Kingdom as a clean burning **Defra Smoke Exempted Appliance**. The CO, NO_x, PM and OGC emissions, heat output and efficiency data have been independently verified by Hetas for the **SIA (Stove Industry Alliance) Ecodesign Ready** scheme. This appliance has also been registered on the **HARP Database** which can be accessed for **BER** and **SAP** calculations.



This instruction manual is also used for a number of other free-standing stove models in the Hi-Flame product range and therefore some of the stove photographs, which are used for guidance purposes only, may differ slightly from your new stove. However, the principles illustrated remain the same.

© 2019 / 2020 Hi-Flame Fireplace UK Limited

INTRODUCTION

Thank-you for purchasing this new Hi-Flame Ecodesign wood burning stove. We are confident that with its state-of-the-art combustion technology and ultra-low emissions it will not only provide you with highly efficient carbon neutral heat but also give you very many years of pleasure at it takes centre stage in your home.

However, before you install or operate your new stove please carefully read this booklet which contains important safety advice as well as instructions which will help you make the most of your new stove.

All users of this stove should be aware of the contents of this handbook and in particular how to operate the stove efficiently to help minimise smoke and emissions. If other people are going to operate the stove then please keep this booklet handy so that it can always be quickly referred to. Never let anyone use the stove who is unfamiliar with its correct operation.

INSTALLER SAFETY FIRST

BS 8303 Code of Practice

Please refer to the current issue of British Standard BS8303, Code of Practice for installation of domestic heating appliances burning solid mineral fuel (this has recently been revised). Make reference to Building Regulations, Local Authority byelaws and other specifications / regulations as they affect the installation of this appliance. See page 12.

Health and Safety

During the installation of this stove and any related building works you must comply with any current Health & Safety at Work regulations. When the stove is fired up always

wear protective gloves (not included) and use the tool supplied when adjusting the stove's air control.

Asbestos

This stove does not contain Asbestos. However, check that there is no possibility of disturbing any asbestos-based materials during its installation. You may intend removing an older appliance prior to installing your new stove, and you should be aware that the old appliance or installation could incorporate heat protective asbestos sheet. Use appropriate protective equipment and seek specialist guidance at www.hse.gov.uk/asbestos – do not underestimate the potential dangers of Asbestos.

Fire Cement

Some types of fire cement are caustic and should not be allowed to come into contact with the skin. Protective gloves and glasses should be worn when applying fire cement. In case of contact wash immediately with plenty of water. Always read and follow the fire cement manufacturer's instructions. Care should also be taken to avoid unnecessary contact between the stove's surfaces and the fire cement as this could damage the paintwork. Any excess fire cement should be quickly removed before it hardens.

Handling

This stove is extremely heavy and therefore adequate facilities must be available for its safe loading, unloading and site handling. This will normally require two people.

Metal Parts

When installing or servicing this stove care should be taken to avoid the possibility of personal injury from the stove's metal parts. Particular care should be taken to avoid sharp edges when handling or attaching the flue liner.

ECODESIGN REGULATIONS PRODUCT FICHE

EU Commission Delegated Regulation 65 / 2014

hi-flame

OUTSTANDING WOOD BURNING STOVES

www.hi-flame.co.uk

www.hi-flame.ie

Trademark	Hi-Flame
Product Name & Model Number	Hi-Flame R4
Product Description	Solid Fuel Roomheater (Wood)
CE EN Standard Type Test	EN 13240:2001 + Amd 2:2004
EU Notified Test Body / Number	SGS Nederland BV Notified Body 0608
Nominal Heat Output	3.7 kW
Nominal Net Efficiency	76.4%
Nominal Gross Efficiency	69.5%
Seasonal Efficiency / EEI <small>Under average climate</small>	100.7
Seasonal space heating energy efficiency band	A

NB See the specific instructions for assembly, safely installing and maintaining this stove.



ENERG

енергия · ενεργεια



hi-flame
MULTI FUEL STOVES

Hi-Flame R4 / R4-LS
Wood Burning Stove

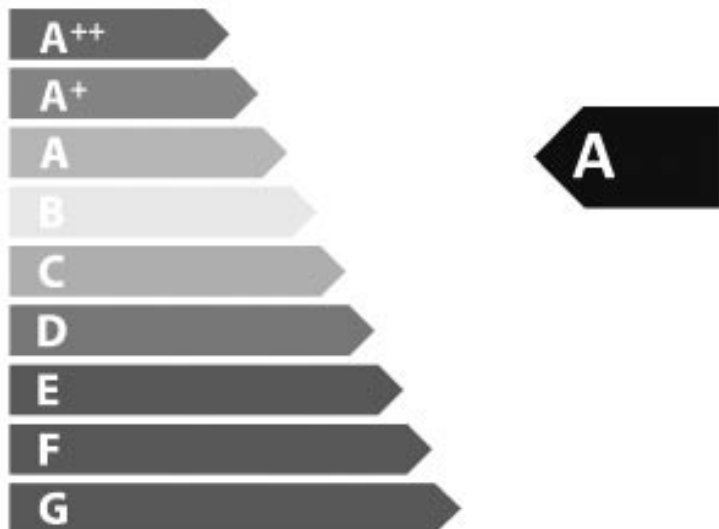

ENERGIA · ЕНЕРГИЯ · ΕΝΕΡΓΕΙΑ · ENERGIJA · ENERGY · ENERGIE · ENERGI

2015/1186

R4 / R4-LS TECHNICAL DATA

Hi-Flame Fireplace (UK) Limited declare that the test stove submitted for type testing of the R4 model represented the full production model specifications in all critical technical parameters needed to fulfil the requirements of the testing standard EN 13240:2001 and EN 13240-A2:2004. No modifications were required to the items tested in order to meet the requirements of the standard. All applicable criteria on the type test have been passed in respect of the materials, design and construction as well as the instructions and marking. Data shown here is derived from SGS Nederland BV (Notified Body) tests during November 2018 (report number EZKA/2018-05/00015-5).

General Specification

Model Name	Hi-Flame R4
Model Number	R4 / R4-LS (with stand)
Dimensions (mm) R4	H455 W370 D323
Dimensions (mm) R4-LS	H565 W370 D323
Net Weight R4	45.0kg
Net Weight R4-LS	56.0kg

Data from CE and Ecodesign Tests

Nominal Heat Output	3.7 kW
Efficiency (net)	76.4%
Mean CO Emission (at 13%) Vol%	0.10
NOx (at 13%) mg/m ₀ ³	116
OGC (at 13%) mg/m ₀ ³	105
PM / Dust (at 13%) mg/m ₀ ³	22
Mean Flue Gas Temperature	240°C
Flue Gas Mass Flow	4.2 g/s

Minimum Distance to Combustibles

Rear	400 mm
Sides	400 mm

12mm Hearths

The R4 and R4-LS are suitable for installation on 12mm non-combustible decorative hearths – subject to Building Regulations.

Tested hearth temperature >85°C

Flue

This stove must not be installed in a shared flue

Flue configuration	Top only
Flue pipe diameter	125 mm
Minimum diameter required for chimney system and connecting flue pipe	125 mm
From centre of top flue to back	*132 mm

This excludes any gap required between the DEAS inlet and the back wall of the fireplace.

Minimum flue height required from the top of the stove	4500 mm
Minimum flue pressure	12Pa
Recommended flue pressure range	12 – 18Pa

See pages 35 to 37 regarding the appropriate flue pressure and spillage tests required during commissioning installations with DEAS.

Air Supply

In pre-2008 dwellings a dedicated air vent' is not usually required for this stove (subject to Building Regulations). In dwellings built after 2008 then a dedicated air supply is required to ensure the safe operation of the stove. This air can either be supplied via a vent to the room or via a direct external air supply (DEAS) using the stove's air inlet and appropriate non-combustible ducting. See page 35 to 37.

DEAS inlet external diameter	75 mm
------------------------------	-------

Fuel

Seasoned wood logs with a moisture content of less than 20%

Recommended maximum log length	250 mm
Recommended fuel load	0.80 kg (1lb.12oz)

For more information about wood burning and buying seasoned wood please visit the Ready to Burn scheme (supported by Defra) www.readytoburn.org.

Modifications

This stove must not be modified in any way – modifications could affect its safe performance.

CRITICAL SAFE DISTANCES

Fireplace Openings

When this stove is installed within a fireplace opening the appropriate air space must be provided to ensure the free movement of the radiated heat and hot air. If this is restricted it could affect the stove's safe and efficient operation as well as shorten the lifespan of the stove components and, in particular, the vermiculite insulating panels and baffle plate. Reducing these distances could also create 'hot spots' which could potentially damage the fabric of the fireplace or chimney breast.



See Hearth Requirements below

Recommended Minimum Air Space inside a Fireplace

A Sides	100 mm (4")
B Rear	75 mm (3")*
C Top	150 mm (6")

*To ensure the stove's safe operation when not using the direct external air supply (DEAS) you must allow sufficient space for the free movement of air around the rear air inlet at the base of the stove (this supplies all of the combustion air to the stove).

If space is limited between the back of the stove and the rear wall of the fireplace then, if necessary, it is acceptable for the installer to trim the air inlet to provide the required 35mm gap between the inlet and the wall to ensure an ample air supply. Under no circumstances should the air inlet butt up against the fireplace wall.

When using DEAS you must allow clearance space for any non-combustible ducting.

CE Tested Minimum Distances to Combustible Materials

Rear	400 mm (8")
Sides	400 mm (16")

Always Allow Space for Maintenance

You must leave sufficient space around the stove to allow easy access for regular maintenance. This is particularly important if you intend to use the rear fitting flue option with a T-piece flue pipe as you will need to be able to access the T-piece trap and be able to easily and securely refit the cap after cleaning.

Hearth requirements

CE tested maximum surface temperatures for this appliance:

Floor below the stove	53°C
Floor 500mm in front of the stove	61°C
Floor 900mm in front of the stove	61°C

R4 MODEL GENERAL DIMENSIONS

All dimensions in mm. Check critical dimensions on site.

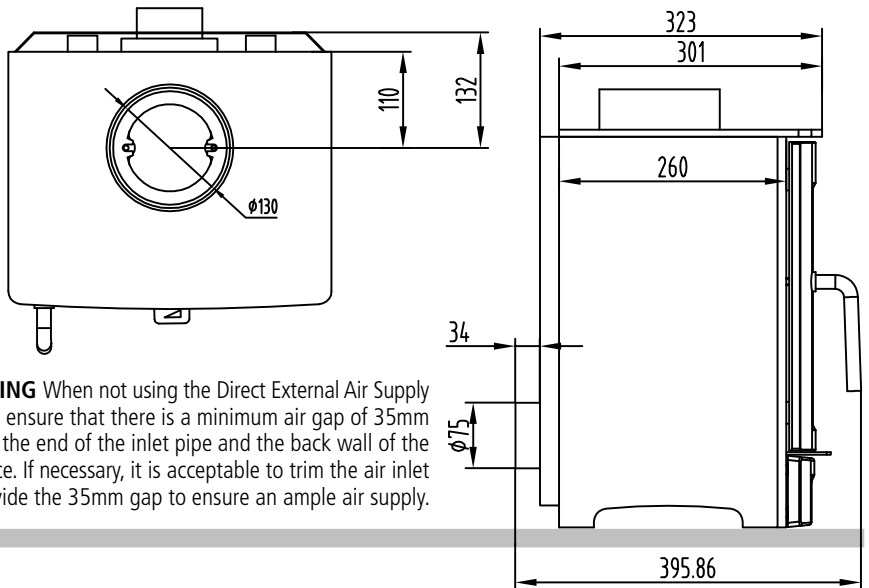
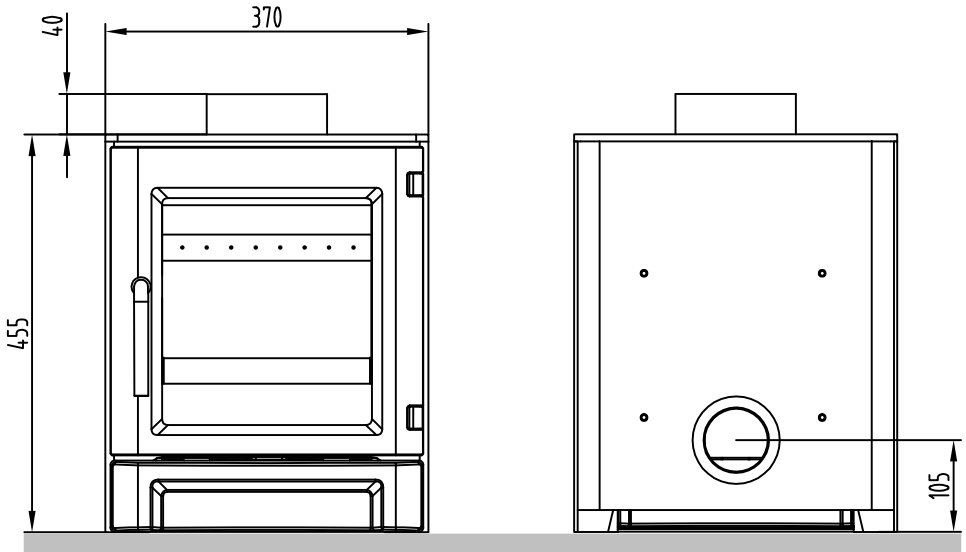

WARNING When not using the Direct External Air Supply you must ensure that there is a minimum air gap of 35mm between the end of the inlet pipe and the back wall of the fireplace. If necessary, it is acceptable to trim the air inlet to provide the 35mm gap to ensure an ample air supply.

R4-LS MODEL GENERAL DIMENSIONS

All dimensions in mm. Check critical dimensions on site.

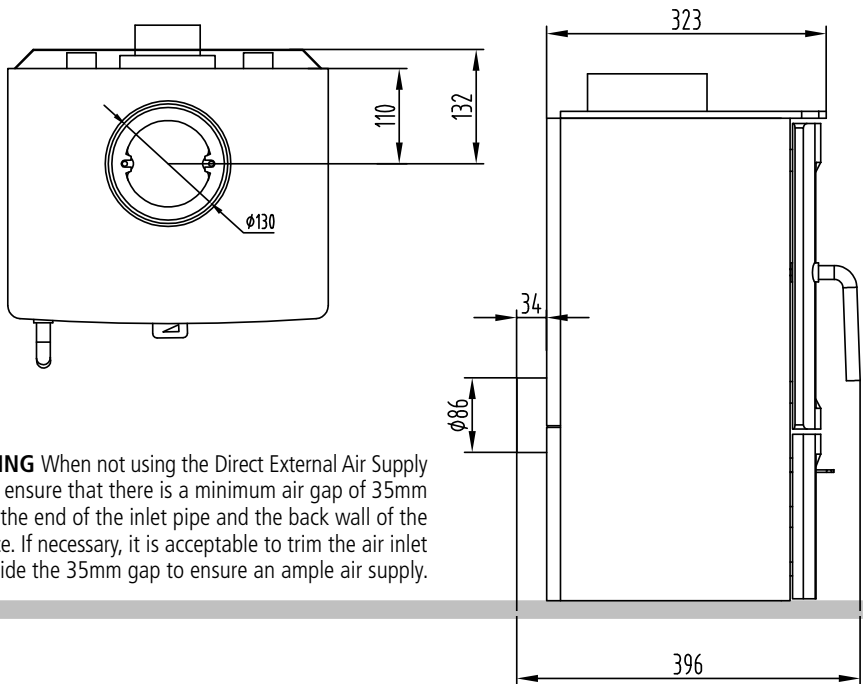
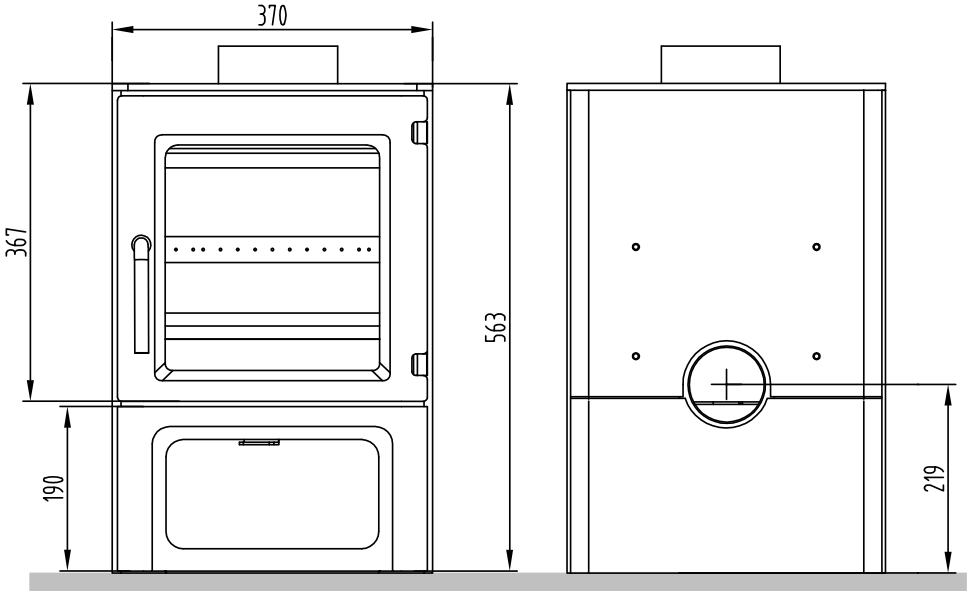

WARNING When not using the Direct External Air Supply you must ensure that there is a minimum air gap of 35mm between the end of the inlet pipe and the back wall of the fireplace. If necessary, it is acceptable to trim the air inlet to provide the 35mm gap to ensure an ample air supply.

STANDARD FEATURES

1 Combustion Air Control

For ease of use, there is only one combustion air control on the R4 and R4-LS. This will deliver both the correct mix of primary air (required at the ignition stage) as well as the pre-heated secondary air supply which controls the airwash system and the flame pattern when the logs are fully alight. Pre-heated secondary air ensures that there is no incoming cold air to cool the firechamber and reduce the stove's efficiency.

2 Pre-heated Tertiary Air System

Pre-heated air enters the stove through jets in the tertiary air bar at the rear of the firechamber. By introducing a new supply of warm

combustion air just as the flue gas is about to leave through the flueway this ensures even more unwanted particulates are burned off helping to keep emissions to a minimum.

3 Airwash System

Part of the secondary air control system which diverts pre-heated air down along the front of the glass to burn off unwanted dry sooty particulates and help to keep it clean. Burning wet or unseasoned wood will reduce the firechamber temperature and cause the airwash system to fail leaving tarry condensates on the glass which will be difficult to remove if left.

4 Top Flue

This Defra exempted stove has a 125mm (5") top flue outlet only.



ASSEMBLING THE STOVE

Your new Hi-Flame stove is extremely heavy. Always handle it with care and make sure that you have additional strong help when you move it. The door and door handle, should not be used to grip the stove as they could be damaged from supporting the stove's weight. If necessary, the fuel retaining bar can be removed to help reduce the weight. Under no circumstances should the door be removed as this will invalidate your Hi-Flame Warranty.

Unpack

Remove your new stove from its recyclable packaging. Retain this until the stove is installed and is fully operational. Unfasten retaining wires and remove any components from inside the stove.

Inspect

Please inspect the stove to check that it has not been damaged in transit – never attempt to install a stove which has been damaged. If damage is suspected then report this immediately to your stove dealer.

Check

Study the component packing list on page 3 and make sure that you have all the components listed before proceeding. Some components may be contained inside the firechamber.

Baffle Plates

There are two baffle plates inside the roof of the firechamber. The lower baffle plate is made of vermiculite and the upper baffle plate is made from plate steel. Check the position of both baffle plates to ensure that they have not moved when the stove was transported. Essentially they should be securely positioned parallel to each other. For more detailed information about fitting and removing the baffle plates see page 31. It is best to fully familiarise yourself with the correct location of the baffles by practising removing and re-fitting

them prior to the stove's installation as you will need to regularly check this area and access the flueway to avoid potential soot build up and blockages.

Flue Outlet

This stove is already configured for the preferred top flue outlet.

Your stove is now ready for installation.

Locating the stove

Do not drag the stove. Always lift the stove to finally position it and use strong help. Alternatively it may be possible to place the stove on heavy duty plastic sheeting or thick floor covering to slide the stove into position, being careful not to damage any finished hearth or floor surfaces with trapped grit or debris.

INSTALLATION REGULATIONS

This stove must be installed by a recognised competent person who is appropriately qualified to ensure that the installation complies with all local, national and European Building Regulations. Failure to comply with this may invalidate the Hi-Flame Warranty. We therefore strongly recommend using a Hetas Registered Installer (www.hetas.co.uk). Your authorised Hi-Flame dealer will also be able to help and advise you.

Current Building Regulations

England & Wales

Building Regulations Document J (revised October 2010) – Combustion Appliances and Fuel Storage Systems. Download this at www.planningportal.gov.uk

Scotland

Building Standards (2001) Domestic
Download this at www.sbsa.gov.uk

Northern Ireland

The Building Regulations (Northern Ireland) 2000 / Amendment No 2 2006. Download this at www.buildingcontrol-ni.com

Isle of Man

Building Regulations (2007) – Isle of Man
Download this at www.gov.im

Republic of Ireland

Approved Document J – Heat Producing Appliances (Revised September 2014)
Download this at www.environ.ie

FURTHER INFORMATION POINTS

The Stove Industry Alliance (SIA)

The SIA promotes and explains the benefits and environmental advantages of stoves and is a great source of well-researched information. www.the-stove-industry-alliance.co.uk

Hetas

Hetas manage the competent persons scheme for stove installations and also promote and

monitor continuous improvement in the safe installation and use of stoves. www.hetas.co.uk

The Solid Fuel Technology Institute

For additional useful information visit the SOLIFTEC website www.soliftec.com

Solid Fuel Association (SFA)

The SFA website is also a very good source of practical information www.solidfuel.co.uk

BFCMA

The British Flue and Chimney Manufacturers Association (BFCMA) website, www.bfcma.co.uk produces an authoritative and informative download guide to solid fuel flues and chimneys.

Health & Safety at Work Act

During the installation of this stove and any related building works in your property you have certain responsibilities and must comply with all current Health & Safety at Work regulations.

Approved Chimney Sweeps

There are number of approved chimney sweep organisations in the UK and Ireland, for example:

Hetas: www.hetas.co.uk

National Association of Chimney Sweeps:
www.nacs.org

Guild of Master Chimney Sweeps:
www.guildofmasterchimneysweeps.co.uk

BUILDINGS INSURANCE

Some building insurance companies require you to inform them of the installation of any new fixed heating appliance and to produce a certificate of compliance.

SELLING YOUR HOME

It is now common practice for purchasers' solicitors to request evidence of compliance (either Hetas or Building Control) for stove installations. **Please note** compliance will not usually be provided retrospectively by Hetas Registered Installers.

BASIC INSTALLATION CHECK-LIST

This information is intended to outline the general principles of installing your stove. However, as each installation will vary it is unfortunately not possible for these guidelines to be comprehensive.

- Not only is it a legal requirement to ensure that your stove installation complies with all applicable Building Regulations, it is also a requirement of your Hi-Flame Warranty that the stove is installed by a competent person such as a Hetas registered installer. They will be fully aware of any building and safety regulations which apply to stove installations in your location.
 - The existing constructional hearth and back hearth upon which the stove will sit is suitably constructed and is made from a non-combustible material of the correct thickness so that it conforms to all applicable Building Regulations. The superimposed hearth (the thinner, usually decorative surface, which sits on the constructional part of the hearth) is suitably constructed and conforms to all applicable Building Regulations.
 - The fireplace recess or opening is suitably constructed and any new lintel conforms to all applicable Building Regulations. The recess should be able to accommodate the stove along with the safe minimum operating distances required (see page 8). Any fireplace lining should have the appropriate fire rating.
- NB** Plasterboard is not a suitable lining.
- Any adjacent walls, next to which a free-standing stove is installed, should be of a suitable thickness, made of an appropriate non-combustible material and conform to all applicable Building Regulations.
 - The chimney is of sufficient height and is in good condition and conforms to all applicable Building Regulations for stove installation. Please refer to the to current issues of

BS EN 15287-1:2007 Design, installation and commissioning of chimneys.

NB The minimum flue height required for this stove is 4.5 metres (15'). For shorter flues, the calculation procedure outlined within BS EN13384:1 may be used to determine whether a proposed flue design and height is capable of providing sufficient flue draught.

- Sweep and test the chimney prior to installation.
- The proximity of all combustible materials to the intended stove installation must conform to the minimum requirements outlined within this handbook (see page 8) as well as local, national and European Building Regulations, whichever is the greater. A combustible material is anything which can burn once it gets hot enough and includes plasterboard, skirting boards, wooden fire surrounds, wooden mantles, wallpaper, fabrics and floor coverings. Remember these materials could be concealed behind other materials which on the surface may appear to be non-combustible, for example, plasterboard and stud partitioned walls.
- You must ensure that this stove receives an adequate air supply for its safe performance. In a post-2008 home this must be from either a permanently open air vent or via the stove's direct external air supply. See panel overleaf for houses with MVHR systems. Additional information on air supply requirements is also available on page 34.

ENSURING A SAFE AIR SUPPLY WHEN MECHANICAL EXTRACTION IS PRESENT

Potential depressurisation caused by extractor fans etc must be assessed for any risks and the appropriate 'worst case scenario' spillage tests and flue draught measurements must be undertaken by an appropriately qualified installer during the commissioning process. See the section on Commissioning on page 37.

GENERAL INSTALLATION GUIDELINES

Due to the wide variety of installation locations and types this information should only be considered as general guidance – you must always refer specifically to current Building Regulations which apply to your country or region. For a list of these see page 12.

The Hearth

This stove is suitable for a 12mm thick non-combustible decorative hearth subject to Building Regulations. The hearth must be capable of supporting the weight of the stove (when loaded) along with any flue components which may bear down on the stove.

In England and Wales when this stove is used in a fireplace there is a minimum requirement for the hearth to project 500mm (20") in front of any brick or stone recess and 150mm (6") at each side of that recess.

When using as a free-standing stove the minimum hearth size should be 840mm by 840mm (2'10" by 2'10" approx). The hearth must provide protective coverage for the minimum clearance distances for this stove outlined on pages 7 and 8 and should also extend by a minimum distance of 225mm (9") from the front edge of the stove. The wall behind the stove should be non-combustible or alternatively be adequately protected from heat from both the stove and flue pipe.

Where possible, it is a good idea to extend the hearth to at least 75mm (3") beyond the furthest out-swing of the stove door to avoid any potential live ash held on the door falling on to combustible flooring or floor coverings.

The 'Fireplace'

The stove can be sited within a brick or stone fireplace recess or used free-standing. The fireplace side and rear walls should be at least 75mm thick and made of non-combustible brick or stone. Adequate air space around the stove will allow the stove to radiate heat and

circulate warm air around the room must be provided. This will also prevent any structural damage to the fireplace walls as well as help avoid potentially over-heating the stove and damaging components. For recommended safe distances when this stove is located inside a fireplace – see pages 7 and 8. **Please note** if the fireplace interior needs to be lined you must not use standard plasterboard as this is combustible. Any sheet materials, the supports used behind it and fitting components should have the maximum possible fire rating.

Installing inside a Mock Chimney Breast

if you propose to install this stove within a mock chimney breast and fireplace then extreme care must be taken in all instances to provide the safe minimum distances. Particular attention should be paid to ventilating the structure in order to prevent any potentially dangerous build up of heat inside the structure or to any of its metal fixings. Ideally, the use of combustible materials should be avoided and any sheet materials used should have the maximum possible fire rating. **Please note** standard plasterboard is a combustible material and should never be used.

The Chimney, Flue and Flexible Liners

The minimum flue draught requirement for this stove is 12Pa. Other appliances should not share or be connected to the same flue system or chimney.

If you are using an existing chimney and it has been checked for condition and suitability (see below), in the interests of safety you must ensure that it is swept before the stove is installed, even if it has never been used or you intend to use a flexible liner.

The recommended minimum height for the chimney / flue system from the top of the stove to the top of the chimney terminal is 4.5m (15'). Where this is not possible then the installer must produce a flue calculation which demonstrates that any alternative

the installer must produce a flue calculation which demonstrates that any alternative proposal will deliver the minimum 12Pa updraught required for the safe performance of this stove. Failure to satisfy this requirement could result in the installation failing the commissioning and spillage tests outlined elsewhere in this handbook (see pages 35 to 36) as well as invalidate your extended Hi-Flame Warranty.

This stove features optional top or rear 125mm (5") diameter flue outlets and as a Defra Approved Smoke Exempted Appliance the connecting flue pipe and stainless steel flue liner can also be of 125mm diameter (subject to Building Regulations)

Under no circumstances should the stove's 125mm diameter flue be reduced in any part of the flue system as this could cause a build up of dangerous carbon monoxide (CO) gas.

Although it is possible to sweep the flue system through this stove once the baffle plates have been removed (see page 31) it is recommended that there should be at least one additional cleaning access point within either the connecting flue pipe, twin wall chimney system or where there are bends.

Flexible Flue Liner

Hi-Flame strongly recommend fitting a flue liner when installing this stove within an existing chimney for the following reasons:

- A flue liner is a major 'quantifiable' component which provides a consistent flue diameter and regular inner surface and as such will minimise interference to the updraught and help improve it. When back-filled with vermiculite insulation a liner will keep flue gases as hot as possible which will help improve the stove's operation and minimise the amount of smoke produced.
- An existing chimney could leak smoke, fumes and potentially dangerous 'invisible' carbon monoxide (CO) into other parts of the

building. Condensation or creosote tar, associated with burning wood, could eventually seep through the chimney walls, particularly if they are made of old or porous brick and / or are jointed with lime mortar, eventually causing unsightly stains on decorative coverings.

- Stoves work best with the correct draught. Pre-1965 chimneys which have been built for open fires have larger (and often irregular shaped) voids than those best suited for a modern stove and this could reduce the effectiveness of the flue draught by making the flue too cold and difficult to warm. This is a particular problem if the chimney breast is on an outside wall and / or is subject to a strong prevailing wind.
- Many houses built since 1965 with clay or concrete chimney liners suffer from these being poorly installed, either through being fitted the wrong way up or not receiving an appropriate application of mortar to make a complete seal on each of the many joints. Even though the chimney may not be particularly old, this could still potentially allow smoke and fumes or unsightly condensation stains to leak through.

Chimney Terminal

The existing chimney pot or terminal must be suitable for stove installation and should not restrict the smoke and fumes from the stove. It must provide at least the same outlet area as the flue pipe. It may be that your existing chimney terminal has been replaced with a ventilating terminal if the fireplace has been closed off at some point. Your installer will be able to advise you about the appropriate specification of any new cowl or terminal. Cows have the additional advantage of limiting rain entering the flue system which could cause the inside of the stove to rust when it is not being used, particularly during the long periods outside the heating season.

THE CLEAN AIR ACT 1993 AND SMOKE CONTROL AREAS

Under the Clean Air Act local authorities may declare the whole or part of the district of the authority to be a Smoke Control Area.

It is an offence to emit smoke from a chimney of a building, from a furnace or from any fixed boiler if located in a designated Smoke Control Area. It is also an offence to acquire an 'unauthorised fuel' for use within a Smoke Control Area unless it is used in an 'exempt' appliance ('exempted' from the controls which generally apply in the Smoke Control Area).

The Secretary of State for Environment, Food and Rural Affairs (DEFRA) has powers under the Act to authorise smokeless fuels or exempt appliances for use in Smoke Control Areas in England. In Scotland and Wales this power rests with Ministers in the devolved administrations for those countries. Separate legislation, the Clean Air (Northern Ireland) Order 1981, applies in Northern Ireland. Therefore it is a requirement that fuels burnt or obtained for use in smoke control areas have been 'authorised' in Regulations and that appliances used to burn solid fuel in those areas (other than 'authorised' fuels) have been exempted by an Order made and signed by the Secretary of State or Minister in the devolved administrations.

Further information on the requirements of the Clean Air Act can be found at the following website:
www.smokecontrol.defra.gov.uk.

Your local authority is responsible for implementing the Clean Air Act 1993 including designation and supervision of Smoke Control Areas and you can contact them for details of Clean Air Act requirements.

The R4 and R4-LS stove has a factory-fitted combustion air control damper to prevent

designed to prevent complete closure of the combustion air supply. Both models have 4 permanently open air inlets in the base to ensure the correct quantity of combustion air to keep smoke to a minimum and therefore both have been recommended as suitable for use in Smoke Control Areas when burning wood logs.

Never Burn Wet Wood

The recent media coverage of air quality has increased awareness of this important issue. Wood fuel marked with the 'Ready to Burn' label shows consumers that logs are dry and ready for use as wood fuel, and will burn more efficiently than unseasoned, green wood and will consequently reduce their impact on the quality of our air.

The Woodsure 'Ready to Burn' scheme is supported by The Mayor of London, Defra, Hetas and the Stove Industry Alliance, as well as Hi-Flame.

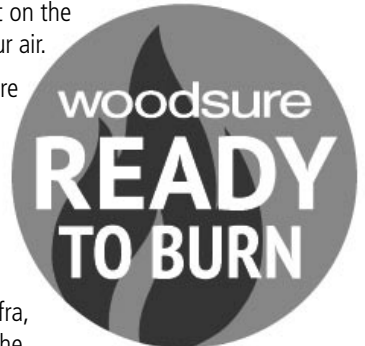

To find out more about the Ready to Burn scheme and the environmental benefits and potential cost savings of burning fully seasoned wood please go to:
www.woodsure.co.uk/firewood-ready-to-burn/

RECOMMENDED FUEL

Wood logs with a moisture content of less than 20% is the only fuel that Hi-Flame recommend for burning in this stove.

CE Standard and other Approvals

Please note that this appliance has been CE and Ecodesign tested for wood only and the heat output, emissions and efficiency data, as well these operating instructions and the Hi-Flame Warranty only covers the use of wood in this appliance. They do not cover the use of other fuels, either alone or mixed with wood

Defra Smoke Exemption

This stove is officially approved by Defra as an 'exempted appliance' to allow the burning of wood in designated UK Smoke Control Areas. It must, at all times, be operated strictly in accordance with the instructions to minimise the amount of smoke produced.

General Guidelines

Only ever use dried, fully seasoned chopped hardwood logs with a moisture content of less than 20%. Wood which is well seasoned makes a distinctive 'clack' rather than a dull 'thud' when knocked together. It will also feel much lighter than an unseasoned log. Other indicators include bark peeling away and cracking and the log splitting around the outside edge.

Ideally wood should be seasoned outdoors for between 18 to 24 months – the harder the wood then the longer the seasoning. It should be stacked off the ground with plenty of space between the logs to allow air movement and with the top covered to keep rain and snow out. Fully seasoned wood will give you approximately 50% more heat output than the equivalent unseasoned log.

Most types of hardwood, for instance Ash (generally regarded as the best), Birch, Beech,

Oak and Elm can be used. However, avoid woods with a high resin content. As a rule of thumb, the heavier the wood, then the greater the heat output and the longer burn time – the time between refills. All of this is providing it is fully seasoned wood.

Never use wet or unseasoned (green) wood as this will cause nuisance smoke and a very disappointing fire. Most importantly, it could quickly result in the build up of soot and creosote which the high temperatures of the stove flue gases could easily ignite and cause a flue or chimney fire. In addition, burning wet wood damages local air quality, produces a less efficient fuel economy and can eventually clog your flue system and cowl. It will also reduce the effectiveness of the stove's Airwash system thus causing staining and blackening of the glass.

Wet or unseasoned wood produces the following poor performance

- Hard to light fires and fires that are also very difficult to keep burning
- Smoky fires with fewer flames which are also of a dull or dirty orange colour
- Increased dense grey or blue smoke from the chimney
- Much shorter burn times with some wood left unburned at the end
- Low heat output despite the poor flames
- Dirty brown glass and black firebricks
- Excessive and rapid creosote build-up inside the flue system and chimney
- Unpleasant acrid smoky smells inside and sometimes outside the house

Manufactured or finished wood products, such as plywood and chipboard, must also be strictly avoided because of the high chemical adhesive content used in their production which could also leave harmful residue inside the stove and flue system.

FUELS YOU MUST ALWAYS AVOID

This wood burning stove has been emissions tested so that when correctly operated it will have a minimum impact on local air quality when only burning wood logs with a moisture content of less than 20%. It has not been tested for burning mineral fuels including smokeless coal. Burning other fuels, apart from logs, is an offence in a Smoke Control Area.

Burning the following materials could also damage your stove and flue system, and will render your Hi-Flame Warranty void.

- **Never use your stove as an incinerator**

Do not burn any household waste such as magazines, newspapers, cardboard, milk cartons, vegetable peelings, plastic and rubber etc.

- **Never burn other types of wood**

During combustion lacquered, painted or tanalised wood, MDF, plywood, chipboard and other manufactured wood could develop substances which may be hazardous to your health and also damage your stove and flue.

- **Never burn petroleum coke**

Never burn petroleum coke (aka pet coke) as this burns at a very high temperature and its continued use will almost certainly cause irreparable damage to the stove components such as the baffle plate and fire fence.

- **Never burn bituminous house coal**

This has a harmful effect on local air quality. When burned it produces excessive smoke and soot with the soot quickly building up inside the stove's flueway and flue which increases the risk of dangerous blockages and chimney fires. Smoky coal has now been banned altogether in the Republic of Ireland.

- **Never burn flammable liquids**

Methylated spirits, petrol or other flammable liquids should not be used to light the stove as these could cause an explosion in the confined spaces of the firechamber.

WHEN YOU FIRST LIGHT YOUR STOVE

Use smaller and shorter 'gentle' fires the first five or six times that you fire up your new Hi-Flame stove, making these progressively larger. This will help temper the steel and cast iron components and avoid any potential thermal shock which could damage them.

This process will also allow the paintwork to cure. In fact, you may notice some wisps of smoke or smell a hint of paint fumes coming from the stove's painted surfaces during these early fires, however this is perfectly normal. Simply ensure that the room is well ventilated until this settles down.

The hotter you burn the stove the more intense these fumes will be, which is one of the reasons that we advise that you use smaller fires to start with. Every time the stove reaches a new higher temperature it may still be possible to smell these fumes or see some gentle smoke until the paintwork is fully cured. If this persists or gets any worse beyond the first few fires then do not use the stove and immediately consult your stove installer or stove dealer as this may indicate a potential problem with the installation. See page 2.

Always allow the stove to fully cool down between these first fires.

ESSENTIAL SAFETY ADVICE

- Ensure that an approved carbon monoxide (CO) detector (BS EN50291:2001) is fitted in the same room as the stove and is regularly tested. The CO alarm must be installed strictly in accordance with the manufacturer's instructions and permanently fixed so that it is best placed to monitor the earliest signs of CO escape. It should be powered by a battery designed for the working life of the alarm (usually five years). Hi-Flame recommend Honeywell or Fire Angel models. Do not be tempted to buy a cheap alarm as recent research by the UK consumer organisation Which? has shown that many of the cheapest models simply do not work effectively.
- Never operate this stove with the door open except as directed in these instructions and when this should be kept to a minimum and the stove not left unattended.
- External surfaces including the firechamber door and handle, window, air control, flue pipes and stove bodywork will become extremely hot. Always avoid touching these parts of the stove without proper protection, such as heat resistant gloves.
- Potentially combustible material or objects such as soft furnishings should never be left on or near any of the stove's hot surfaces. Ensure that wood supplies and log baskets are kept at a safe distance from the stove. Never dry clothes on the stove.
- Never leave children unattended in the room where your stove is being operated. Ensure that children are aware of the potential danger and make sure that they keep clear of the stove when it is in operation. Where children, the elderly or the infirm are present, to prevent accidental contact with the stove, always use a safety fireguard manufactured in accordance with BS8423:2002, Fireguards for use with solid fuel appliances.

- For your safety make sure that your stove's installation complies with all local Building Regulations' ventilation requirements. Low energy houses have particular requirements and these should be strictly adhered to.
- Do not use flammable liquids to ignite the fire. In the confined space of the firechamber there is a real potential to cause a life threatening flash flame or explosion.
- Never over-fire the stove. If any external parts of your stove glow red during operation then immediate action should be taken to reduce the supply of air to the firechamber through the air control which should quickly limit the intensity of the fire. Do not open the firechamber door as this will only make the fire worse. See pages 25 and 26.
- This stove is CE approved and tested to EU EN13240 standards in Europe by SGS Nederlands BV. Alterations to its construction could be potentially dangerous and will render your Hi-Flame Warranty void.
- Do not use aerosol products in the vicinity of the stove when it is in use.
- Check and clean the stove's flueway and the top of baffle plate regularly to help avoid potential blockages (see page 31).
- Check the direct external air system's outside vent' grille to ensure there are no blockages arising from new foliage growth, wind-blown debris and leaves or snow drifts.
- Sweep your chimney or flue system regularly. Always use an approved sweep who has experience of sweeping stove installations.

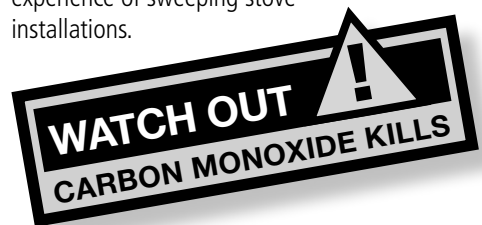

THE BETTER WAY TO BURN WOOD

Wood takes its combustion air from above the firebed and will always burn best on a bed of embers (approx 25mm deep). For this reason you don't need to clean out the ash bed, except perhaps if it overflows (and then you only need to remove some of the ash) or if you are standing down the stove at the end of the heating season (see page 38). You do not need to riddle the embers either except to gently tamp them down to make a level bed when you are refuelling, but even this may not usually be necessary.

Your new stove can burn very well, or very poorly, depending on how you light the fire, how you refuel the fire, and, of course, the type and quality of the fuel that you are burning. A flue temperature gauge and log moisture meter are both cost-effective investments and both are highly recommended if you want to maximise the efficiency of your stove and minimise the amount of logs that you use.

Always wear protective gloves when loading a burning stove and place logs and other fuels precisely where you want them by using heat-resistant tongs. Never throw the logs in.

When refuelling always open the stove door gently to avoid unnecessary air turbulence which could cause ash or small lighted embers to be drawn from the firechamber and beyond the protective hearth. Never operate the stove

It is unsafe to operate this stove with the door open. The only exceptions to this are at the lighting phase when it can be left slightly ajar for the first few minutes to provide a boost of combustion air for a quicker start and only ever when the stove is attended or when refuelling, when this should be kept to a minimum.

without the fire fence being in place.

When burning logs the end grain of a log will allow any remaining moisture and gases to escape, therefore always point log ends away from the glass to prevent the glass staining.

- **Ensure your logs are ready to burn**

Always use fully seasoned or kiln dried logs with a moisture content of less than 20%. Unseasoned logs (aka wet or green logs) do not provide the same fuel efficiency, will burn poorly, produce less heat and will also produce creosote tars which will quickly stain the glass, clog the flueway and chimney system, potentially making the stove unsafe to use. Burning wet wood produces an excessive amount of dirty smoke which will be extremely damaging to your local air quality.

- **The ideal Log**

We recommend that hardwood logs should be approximately 250mm (10") long. This provides sufficient air space at either end of the log to allow any moisture and combustion gases to escape freely. This size will also limit potential damage to the vermiculite panels from any over-sized logs knocking into them.

Do not be tempted to use over-sized logs as they could be very slow to light and could also create excessive smoke. When they eventually catch fire they could very easily over-fire the stove.

Ideally you will need three different thicknesses of wood log as you start the fire and then build it up through each lighting phase.. A detailed description of these sizes and how important they are to getting an effective fire quickly established is discussed overleaf (page 21).

OPERATING YOUR STOVE

When lighting your stove you will need to get the temperature in the firechamber as high as possible as quickly as possible. This is critical for creating a good updraught or 'draw' within the flue system, especially when it is particularly cold outside. It is also important to maintain the operating temperature of the firechamber above 120°C, below which combustion is incomplete and creosote tars are formed within the combustion gases. Burning the stove like this will create dull orange flames loaded with soot and will not actually generate much heat.

Use firelighters specifically designed for stoves and avoid lighting the fire with paper as the ash it leaves behind can 'smother' and reduce the effectiveness of the ash bed. If you have good dry kindling or sticks then paper should not be needed.

The best sizes for the logs

The recommended log length for this stove is 250mm long, however the thickness or diameter of the logs used at each phase of lighting and refuelling is just as important. For example, logs that are too heavy and big when added at the wrong time may be problematic as they can 'kill' the fire. Below is our rough guide for the various thickness of logs needed for ease of use during a complete burn cycle. See photograph right.

Kindling (A) This is generally finely chopped wood, approximately 5 to 10mm thick from your supply of logs. Alternatively use softwood, or dried twigs and small branches which have also been fully seasoned.

Lighting Logs (B) These are slightly thicker logs, approximately 25 to 50mm across.

Refuelling Logs (C) These should be approx 75 to 100mm across. Thicker logs should ideally be split to this size.

Basic Lighting Methods

We've outlined two tried and tested methods for

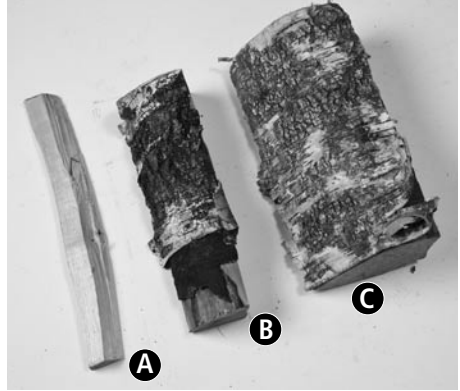

lighting your new stove. These may be different from how you have been used to lighting your open fire or old stove. Always remember...

- Never overload the stove or place fuel against the tertiary air jet bar
- Never leave the stove unattended if its door is ajar
- Never throw logs into the stove as this could damage the vermiculite panels or glass
- Always refuel logs on to a bed of hot embers
- A single dense log will not burn as well as 2 or 3 smaller logs of equivalent mass
- 2 or 3 logs tightly packed beside each other will burn for longer but at a lower temperature than loosely criss-crossed logs
- Avoid setting the ends of the logs pointing towards the glass as this can cause staining which the airwash may not remove
- Load the fuel as quickly as possible to avoid letting the fire chamber cool
- Using a flue pipe thermometer. This will indicate inefficient burning, which creates smoke and creosote, as well as over-fring

The 'Top-Down' fire lighting method

In order to minimise the amount of smoke produced when you first light your stove we recommend the following Scandinavian 'top-down' method. This may seem counter-intuitive if you're used to lighting an open fire, but you'll soon find this actually works really well and, of course, it's so much better for our air quality. This method also reduces the

number of times that you will need to check and refuel the stove during a typical burn cycle.

1 Loading

Fuel Load: Kindling (A) & Logs (B & C)

Place 2 of the larger logs (C) at the base of the fire chamber. Add 2 or 3 of the smaller logs (B) on top of these. Leave some air space between them. Next add a good-sized handful of kindling (A) criss-crossed on top (see below). Position 1 or 2 fire-lighters amongst this and quickly light them. Ensure the air control is fully open. You may need to leave the stove door slightly ajar to improve the combustion air supply. Close the door whenever the kindling has burned away and the lighting logs (B) are fully alight. If the flames are diminished by closing the door then leave open for a little longer. When all of the logs are burning and have turned a ash grey then you can begin to moderate the flame and heat by adjusting the air control. You should not need to return to the stove until it needs refuelling.

2. Refuelling

Fuel Load: Approx 50kg of Logs (B & C)

Approximately 0.50kg of logs (2 or 3) can be added when refuelling. The best time to refuel is while the stove is still giving out heat and there are sufficient remaining burning embers. Fully re-open the air control. Embers should be spread evenly before the new logs are added. Always use a heat resistant gauntlet or tongs to precisely position any new logs. Be careful not to add too many logs as they may 'smother' the fire. There should be no need

to leave the door ajar. Again, wait until all of the logs are fully burning and their surfaces are grey before the supply of combustion air is reduced. This will ensure that the firechamber is operating at full temperature and will help keep smoke and emissions to a minimum. Reducing the air supply will allow you to control fuel economy.

'Traditional' fire lighting method

This method may be more familiar to you and will provide you with an equally good fire at the end of it. However, it may take a little more work than the 'top-down' method.

1 Loading & Lighting

Fuel Load: Kindling (A)

The air control should be fully open (slide to right). Use 2 handfuls of kindling (A), at least equivalent to the weight of a typical log. Layer this criss-cross or 'wig-wam' style over 1 or 2 firelighters which should then be set alight. If the kindling fire is slow to get started then you may need to leave the door slightly ajar, but do not leave the stove unattended. On particularly cold days add significantly more kindling to quickly warm the flue to create a stronger updraught. When the kindling is burning well close the door. However, if this slows the fire then continue with the door ajar until closing it does not affect the fire. After about 6 or 7 minutes you can add some wood.

2 The Firing Phase

Fuel Load: 3 or 4 logs (B)

Once the kindling flames starts to calm down the first refuel can take place. For this use three or four slightly thicker pieces of wood (B). These should be thicker than the kindling, but smaller than the main logs (C). Large pieces of wood placed on the embers at this stage may be slow to ignite causing the firebox to loose heat and the wood to smoke. Doing this will actually take much longer to get the fire going. After about 7 to 10 minutes, and only

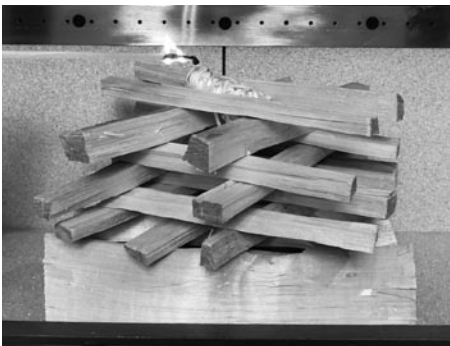

when all of the logs are fully burning and their surfaces have turned grey, should you add the main logs (C)

3 The Main Firing Phase

Fuel Load: 2 or 3 larger logs (C)

Once the embers of the first refuel phase are glowing then these can be evenly spread with a poker and approximately 1.0kg of larger logs (C) can be quickly loaded – usually about 2 or 3. Use a heat resistant gauntlet or tongs to precisely position the logs. Be careful not to add too many logs as they may ‘smother’ the fire. Fully open the air control until the logs are fully alight and their surface is ash grey, after which you can then adjust the flame height and heat output to suit – but not before. This will allow you to control fuel economy.

4 Refuelling

Fuel Load: 2 or 3 main logs (C)

For best results fully open the air control (slide right). This will make any remaining embers glow red which can then be spread. If the ember bed is weak you may need to add some kindling to re-establish the fire before 2 or 3 of the larger logs (C) are then gently added, ensuring that the logs are not tightly packed. Again, only when the new fuel is burning well and the logs have turned a light ash grey, adjust the air control to your requirements. Never overfill the firechamber and also avoid over-sized pieces of wood which will ‘slow’ the fire down at the start but then could lead to over-firing later.

Ensuring that the airwash works

Getting the balance right between a gently burning stove and one that is burning too low, creating smoke and causing the airwash to fail, and consequently the glass to stain, is very much a matter of trial and error. If you are burning fully-seasoned wood then a quick ‘blast’ of the stove at ‘full throttle’, with the air fully open, should quickly burn off any

deposits left from slumber burning.

Instructions for Smoke Control Areas

To meet your legal obligations when operating this stove in a Smoke Control Area this stove must be operated correctly to minimise the amount of smoke it produces.

- Burn only dry fully seasoned wood with a moisture content of less than 20%. Never burn wet or green wood.
- Do not overfill the stove so that you have to turn it down for long periods as this will create smoke.
- This instruction book should be left with the end-user and anyone who will use the stove.

Refuelling on to a low firebed

You must ensure that there is a sufficient quantity of glowing embers so that the new fuel charge will quickly ignite. Refuelling on an inadequate bed of embers will create excess smoke and will take much longer. It is very much easier and quicker to ‘start’ again by adding a suitable quantity of kindling to the remaining embers ensuring that there are sufficient brightly burning flames before medium sized logs are added.

Never overload this stove

The maximum amount of fuel specified in this manual (see page 7) should not be exceeded. Overloading can cause excess smoke and is also dangerous.

Never operate the stove with the door open

This stove is not designed to be operated with the door left open, except as directed in these instructions. This can cause excess smoke and can also be dangerous.

Avoid operating this stove with the air control left fully open

Using this stove with the air control left fully open can cause excess smoke. This stove must not be operated with the air control or door left open, except as specifically directed in these instructions. See pages 21 to 24.

SOME SIMPLE TIPS

- 1** When refuelling use small regular loads as this will produce a more efficient and cleaner burning performance.
- 2** If you have inadvertently let the fire burn down so that there are just a few burning embers then avoid reloading with large 'cold' logs as the fire will be very slow to re-establish itself, possibly even going out as the new load reduces the existing fire's access to a sufficient supply of combustion air.
- 3** Avoid burning large amounts of wood with the Secondary air supply turned down as this will reduce the effectiveness of the Airwash system and will result in dirty glass, as well as excessive smoke and a potential build-up of creosote tars.
- 4** Never use big, heavy logs as these will introduce a large cold spot inside the hot fire-chamber. They will be very slow to light and consequently will create unnecessary smoke over a much longer period. They could possibly even cause the stove to over-fire when they eventually catch alight. It's always safer to split these down.
- 5** Burn on a high output for approximately 30 minutes each day to 'burn off' any potential soot and creosote build-up – but be careful not to over-fire the stove. This is particularly important if you regularly burn low for long periods such as overnight burning.
- 6** Bright vibrant flames and a clean firechamber indicate that your stove is operating well. Lacklustre dirty orange flames indicate a poor performing stove which will produce excessive smoke and very little heat – see the Trouble-shooting section on pages 25 to 30.
- 7** Never overload the stove – it will be smoky and inefficient as well as very slow to establish a good burn and could possibly eventually over-fire.

REMOVING ASH

As a wood burning-only stove this stove does not feature a removable ash pan. This is because fully seasoned wood, which has been efficiently burned in a stove, will produce very little ash. In addition, you do not need to clear the firebed very often, but allow the ash to build up to a depth between 25 to 30mm. This ash bed will actually help the wood to burn more efficiently.

Should there be any pieces of wood left after the fire has gone out and the stove is cold this would indicate one of two things – the original wood was wet and reduced the firechamber temperature to a point where combustion could not be completed – in which case change your fuel. Or, that the stove's air supply is insufficient and cannot promote and maintain an effective flue draught all the way to the end of the burn cycle, in which case please check the trouble-shooting section on page 25 or consult with your original installer.

You only ever need to empty the firebed if it gets too full of ash and this creates nuisance fly-ash or when standing down the stove at the end of the heating season.

Never attempt to remove the ash when the stove is hot. Always wait until you are sure that the stove is cold and there are no potential live embers. Remove the ash with a small shovel taking care to protect decorative furnishings and porous surfaces against potential ash spillage. As you remove the ash from your home ensure that it is covered to protect it from any draught or wind which could blow the ash out of its container.

Remember that you can recycle your wood ash in the garden compost.

TROUBLE-SHOOTING

These pages should be your first reference point if you experience any problems with the operation of your stove. Only contact your stove installer or dealer after you've read the advice here and if you still cannot resolve your particular issue.

If your stove has been installed and operated correctly, and you have also carried out the recommended routine checks and annual servicing, as well as sweeping the chimney, then it is unlikely that you will ever experience most of the problems outlined below:

- 1 Chimney fire
- 2 Stove, flue or other components glow red
- 3 Smoke and fumes escaping into the room
- 4 Overheating or excessive fuel consumption
- 5 Stove not providing enough heat
- 6 Glass staining or blackening
- 7 Cloudy or crazed glass

1 Chimney Fire

Chimney fires can be detected by an unusual roaring sound or vibrations coming from the chimney breast, the stove or the connecting flue pipe. The sound is not to be confused with the gentle 'rushing' sound you may normally hear when a stove has a well-performing updraught. You may also see sparks or flames exiting from the chimney terminal.

What you need to do in the case of a chimney fire

If you suspect a chimney fire then immediately close off the air control to starve the flames of combustion air. DO NOT open the air control or the stove door as this will only make the chimney fire worse by providing additional combustion air. Next, evacuate the building and call the Fire Brigade. Do not re-enter the

building until you have been advised by the Fire Brigade that it is safe.

Do not re-light the stove again until the flue system has been thoroughly inspected by an approved installer or chimney sweep and any necessary repairs have been carried out.

Likely causes of chimney fires and how you can help to prevent them

Chimney fires occur when soot and creosote have built up to such a level in the flue system that they eventually ignite. It is important therefore that your installation features as many cleaning access points as practicable to enable comprehensive removal of soot, creosote and other debris from every point in the system. This will also minimise the amount of time it takes for a qualified sweep to clean the system making the system safer and its cleaning more cost-effective in the long run. The Fire Service recommend that wood burning stoves ideally should be swept twice in a heating season depending on usage.

Avoid continuous low burning

To discourage the potential for such soot and creosote build-up, long periods of consistent slow or overnight burning should be avoided or at least be compensated for by regular burning on full output for short periods afterwards (eg 30 minutes per day) to help burn off any likely deposits before they become problematic.

A good flue temperature thermostat will indicate the flue gas temperature and help you avoid operating your stove at a temperature which promotes the conditions to create creosote deposits (basically operating your stove at anything less than 120C°).

Never burn unseasoned or wet wood

Unseasoned or damp wood should always be avoided as this produces excessive soot and creosote and will not only help create the conditions for a chimney fire but could also

quickly 'fur up' your flue, potentially causing spillage of carbon monoxide (CO) into your living space.

2 The stove or flue pipe glow red with excessive heat

This situation could potentially cause a house fire and / or damage the stove.

What you need to do

The air control should be immediately closed (slide left) to let the fire die down to an acceptable level and to reduce the heat output which will in turn eliminate the glow from the over-heated components. Over-firing is dangerous and could permanently damage or warp your stove and its components as well as invalidate your Hi-Flame Warranty.

Check the stove and the flue system for any signs of permanent damage before you re-use the stove.

Likely causes and how to avoid them

Over heating (aka over-firing) your stove components is simply caused by over-filling the firebox with fuel so that your stove operates at a much higher output than it was ever designed for. See page 7 for information about the correct fuel load. The excessive heat in the flue system caused by over-firing could also increase the chances of a chimney fire (see Chimney Fires above).

Alternatively, it may be that the stove door has been left open after refuelling so that there has been an over-supply of combustion air and the fuel has been burning out of control. This stove is not designed to be operated with the stove door open except as directed when lighting the fire and refuelling (pages 21 to 23).

3 Smoke and fumes escaping into the living space

Assuming your stove has properly installed (flue height is critical) and operated your stove should not normally emit fumes or smoke

into the room. When first using the stove it is normal to experience paint fumes or see light smoke rising from some of the stove's painted surfaces, but these should eventually pass as the paint cures after three or four firings. Occasional minor smoke escape may also occur during lighting and refuelling depending on particular weather conditions.

What you need to do

Persistent smoke or fumes could be dangerous and in this situation you should take immediate avoiding action by evacuating the building. See page 2 for more information. Open doors and windows to ventilate the room and let the fire go out to allow the stove to cool. Never pour water onto the fire as this could damage the components.

Most importantly, never re-light the stove until the problem has been identified and solved. If the issue cannot be resolved by following the advice below then, in the first instance, seek the expert advice of your approved installer, or authorised Hi-Flame dealer.

Likely causes and how to prevent them

There are a number of factors, either alone or combined, which could cause such problems:

Check for blocked flueway or flue

When safe to do so, examine the flueway above and between the baffle plates for potential blockages as well inside the flue pipe and chimney system via the appropriate inspection hatches. Clear away any soot. Excessive deposits could also indicate that the chimney or flue itself needs a full sweep (see page 31). Such soot deposits may have been caused by slumber or low burning for long periods without the required periods of burning on full power which will usually prevent this happening.

Never burn unseasoned or wet wood

This is one of the worst things that you can do regarding the safe operation of your stove.

Burning wet wood causes the incomplete combustion of the fuel and lowers the fire-chamber temperature and flue pressure so that creosote residue and heavy soot deposits are left inside the flueway and chimney.

These will eventually, and usually very quickly, cause a blockage making it harder for the smoke (and CO) to take its normal safe route through the flue system so that it escapes from the stove and consequently enters the room.

Check there's enough room air

Check that any permanent air vent fitted to supply the extra combustion air required for the stove has not been accidentally blocked. Alternatively, if the stove has a direct external air supply check that the outside grille has not been blocked by leaves, new plant growth or snow.

The addition of any new mechanical extraction in a nearby room could also adversely affect the flue draught pressure so that it is no longer sufficient at the start or end of the burn cycle to safely remove the combustion gases from the firechamber and consequently this will allow them to escape into the room.

A simple way of checking whether or not the stove is receiving enough combustion air is to open a window in the same room as the stove whilst the stove is operating. If this improves the problem with smoke then this would certainly indicate that the stove is being starved of combustion air and the advice of the original installer should be sought.

Consider any extreme weather conditions

High winds or freezing temperatures can also temporarily affect the performance of the chimney draught and consequently its effectiveness in removing smoke and fumes from the stove's firechamber. In the case of freezing temperatures it is important to build a much larger pre-fire than normal to quickly provide the additional heat needed to warm

the flue system and to counteract the much lower temperatures at the exit point of the chimney. Please see the section on lighting your stove on pages 20 to 24.

Consider high winds / Prevailing winds

If the problem is associated with high winds and it becomes a regular occurrence, then you will need to fit a specialist chimney cowl. These are designed to help provide a stable draught and prevent specific types of problems. Specifying the correct cowl should always be left to an approved installer. If your installation features a direct external air supply then check that the outside inlet grille is not subject to the adverse effect of high or prevailing winds and either take steps to relocate it or safely shield it from the wind.

Check if the chimney terminal has become restricted

Check that any summer tree growth or new building work (especially at the beginning of the heating season) has not interfered with the free passage of smoke and flue gases from the flue system or chimney top. New tree growth should be cut back (ensure you comply with any local authority regulations). Where there is new building work always seek the advice of your installer as the height of your flue may need to be increased to compensate for this.

4 Excessive fuel consumption

This can be caused by a number of factors.

Check for faulty Door Seals

The rope seals around the firechamber door could have become worn and may no longer provide an air-tight seal. This will allow a supply of uncontrolled combustion air which will limit the effectiveness of the actual air control, especially when you try to close it down. When the stove is cold, you can easily check this seal by placing strips of paper at various

points on all four sides between the door and firechamber front and checking that when the door is closed the paper is gripped. Any paper which can be removed easily would indicate a weakness of the door seal in that particular spot, in which case a completely new rope seal should be fitted. See the section on fitting a rope seal on page 33.

Consider your fuel choice

The fuel itself may be of poor quality. For example pine and other softwoods will burn much quicker than a good hardwood log, such as Oak or Ash and although this will produce bright vigorous flames it will not produce nearly enough long-lasting heat. Please read the section on burning wood on pages 20 to 24.

Consider excessive chimney draught

This limits the effectiveness of the air controls so that the fire burns with very strong bright yellow flames and with very little difference when the air controls are operated. In such circumstances an adjustable damper or draught stabiliser may need to be fitted to ensure that the stove will always operate under a stable draught which will allow the stove's controls to function correctly. These devices limit the free flow of combustion gases from the stove and so, in the interests of safety, they should only ever be specified, fitted and subsequently tested by an approved installer.

5 Stove not providing enough heat

This problem is also usually indicated by dull orange lifeless flames and wood that remains black when burning instead of light grey. You may even find that some of the wood remains unburned when you return to the stove the next day. A flue temperature gauge will provide you with the best indication of whether or not your stove is operating effectively.

Likely causes and how to avoid them

Poor heat output is more than likely caused by poor fuel, such as 'green', unseasoned or wet wood. We cannot over-estimate how critical it is to use fully seasoned dry wood with a moisture content of less than 20%.

Never burn unseasoned or wet wood

The easiest way to check whether your wood is fully seasoned is to invest in a moisture meter. These are relatively inexpensive and can be purchased from your stove dealer. Seasoned wood with a moisture content of less than 20% will give you approximately 50% more heat than an unseasoned wood log, a moisture meter is a modest investment which will more than pay for itself.

Unseasoned wood, not only produces very little heat, it also introduces unwanted moisture into the firechamber, reducing the stove's operating temperature and thus the effectiveness of the airwash system which will cause the glass to stain. In addition increased soot and harmful creosote deposits within the flue system are also created which could potentially lead to a chimney fire.

Always use the correct fuel load

This might sound a bit obvious but for the stove to work effectively it needs to be filled with the correct amount of wood logs. Check that you're actually adding enough fuel – see pages 20 to 24 for the recommended fuel load. The maximum fuel load for this stove is 0.80kg.

Avoid burning too much softwood

Softwoods such as Pine produce significantly less heat output. They will often burn away much more quickly than hardwoods, without delivering a great deal of heat, and should really only be used as kindling to quickly start the fire during the lighting phase or occasionally when refuelling to a low bed of embers. Never use all softwood for a full fuel load because, although you will quickly achieve a bright

vigorous flame, it is then hard to control the flame and extend the life of the logs because there are simply not enough calories of heat left within the remaining fuel to extend the burn cycle as well as deliver sufficient heat.

Check the air control is used correctly

Ensure that you fully understand how to correctly use the air control. See the section on operating your stove (pages 20 to 24).

A stove with the air control turned down too soon in the burn cycle will cause the wood to smoke and smoulder so that it will provide limited heat output. Ensure that flames cover all of the wood and that all of the wood surfaces are ash grey before you begin to turn the stove down. Never allow the fuel to smoke as this indicates poor and incomplete combustion as well as it delivering an inefficient and ineffective heat supply.

Consider the combustion air supply

Check that any permanent air vent fitted to specifically supply the combustion air required for the stove (including any external air inlet) has not been accidentally blocked and that this is consequently starving the stove of a sufficient supply of combustion air.

A simple way of confirming whether or not the stove is receiving enough combustion air is to open a window in the same room as the stove. If this improves the problem then this would certainly indicate that the stove does not have an adequate air supply and therefore the advice of the original installer should be immediately sought.

Check for blockages in the flueway

When safe to do so, examine the flueway above the baffle plate as well as the flue pipe and chimney system via the appropriate inspection hatches and clear any soot blockages. Excessive deposits could also indicate that the complete chimney or flue itself also needs cleaning. If this soot produces

an acrid odour then this indicates the use of unseasoned or wet wood (see page 31).

6 Glass staining or blackening

Please note that it can be perfectly normal to see some small sooty deposits along the base of the glass after the fire has died down, simply because the airwash system is no longer hot enough to work. This should be very easy to wipe off the next time you use the stove. However, if this staining is brown or sticky and difficult to remove without the aid of stove glass cleaner, then this could indicate the use of unseasoned or wet wood. Glass can be cleaned easily if it is undertaken regularly and if the deposits are not allowed to build up. A proprietary stove glass spray or gel is strongly recommended.

Check the airwash is used correctly

Ensure that you fully understand how the Airwash system works – the lower you turn down the stove then the less effective the airwash becomes as this relies on the pre-heated air being as hot as possible to keep the glass clean. As you begin to use your stove you will be able to determine, through some trial and error, the minimum air setting to ensure that the glass always stays clean. Never turn the stove down until all of the logs are fully alight and their surfaces are a light ash grey colour. Turning down the stove too soon will create sooty smoke and a cooler airwash both of which will promote smoky glass.

Never use unseasoned or wet wood

Burning damp or unseasoned wood will cause the glass to stain as the moisture from the fuel considerably reduces the firechamber temperature in turn reducing the effectiveness of the Airwash system. Burning 'green' wood will also encourage sticky deposits on the glass which will prove difficult for the impaired airwash system to remove.

Avoid continuous low burning

Continuously burning your stove with a very low flame, such as slow overnight burning will also cause the glass to get dirty because the airwash does not get hot enough and therefore some blackening of the glass should be considered a 'trade-off'. In this instance, if you're sure that the logs are fully seasoned and dry, then burning the stove at a high temperature for a short period (say 30 minutes) after a long slow burn will usually burn off any sooty deposits, especially inside the flue where they could prove more problematic in the long run (see the section on Chimney Fires)

It is worth investing in a magnetic flue pipe thermometer which when placed on the connecting flue pipe will allow you to keep the flue gas temperature from dropping below 120°C (the point at which creosote and soot are produced by the incomplete combustion of the logs) and to operate your stove more effectively when you wish to turn it down.

7 Cloudy or crazed glass

Cloudy glass is only cosmetic and the glass's performance is not affected. It is definitely not faulty glass and it is much easier to replace the glass than to try to polish it clean.

Likely causes and how to avoid them

The clouding is caused by unburned acidic condensates etching the ceramic glass. The cloudiness will usually start with a series of white deposits which if left on the glass will damage its surface. Although this problem is normally associated with burning coal it can also be caused by the incomplete combustion of wood, usually when the wood is wet and it has a high moisture content. Therefore, never burn wet wood and avoid long periods of slumber burning, even if the wood has less than 20% moisture. Always try to maintain an effective airwash flow and clean and dry the glass after every time the stove is used.

ROUTINE CHECKS

During routine checks if you notice anything wrong with your stove then it should be rectified immediately. Never use a stove that you know is not fully functioning – this includes flue components.

- Until you get to know your stove check your flue system at least once a month using one of the recommended inspection hatches in the flue pipe or chimney system. After a few checks you will notice a pattern of soot build-up to enable you to determine the inspection and cleaning period best suited to your stove's operation. In any event your flue should be swept at least once a year, preferably prior to a new heating season.
- Check and clear the stove's baffle plates and flueway at least once a month until you can determine a pattern of soot build-up (if any). See page 31 on how to remove the baffle plates.
- Regularly visually inspect any flue pipe joints where fire cement has been used and replace any missing or damaged cement seals using the appropriate heat-resistant fire cement.
- Make sure that the door maintains a good air-tight fit and visually inspect the door rope seals for fraying or other signs of wear. Test the seal if you suspect that it is no longer air-tight and is affecting control – see page 33.
- Check that the glass is not chipped or cracked and that the glass gasket seal is still in good condition. Replace if necessary – see page 32.
- Check the condition of the vermiculite firebricks, firebed and lower baffle plate. Replace any of these if they have been eroded by 20% (approximately 6mm) or show any damage that exposes the stove's bodywork. Cracked bricks can still be used providing they still cover the bodywork effectively.

STOVE MAINTENANCE

Baffle Plates and Flueway

During the heating season check the flueway and the double baffle plates at least once a month to start with and remove any soot deposits. Should these be excessive then have your chimney and flue cleaned. At the same time review your choice of fuel and the way that you operate the stove.

Regular long periods of slow or overnight burning can create excessive soot because the stove is not operating at the temperature required to burn it off before it settles. If this soot is clogged or acrid-smelling then this would indicate that you are burning unseasoned or wet wood.

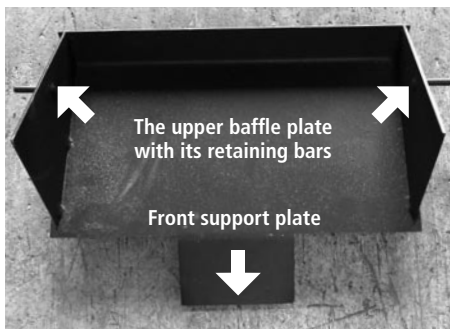
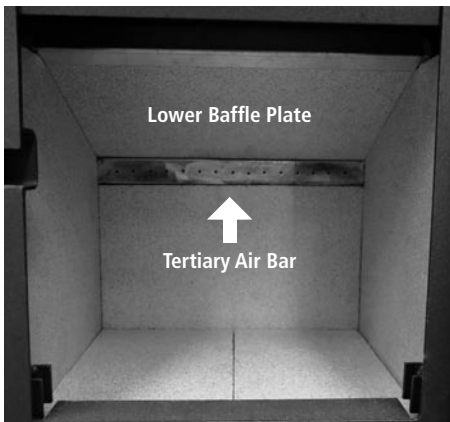

To access the flueway you will need to remove both baffle plates. Once the stove has been

fired this can be quite a dirty job so protective gloves, face mask and goggles should be worn and in addition any porous hearth surfaces and floor coverings should also be protected.

Firstly, remove the firepence at the front of the stove by lifting it upwards and then, if needed, carefully take out one of the vermiculite side panels (you may have to prise this out). You should then be able to push the lower vermiculite baffle plate up and manoeuvre it downwards and out of the firechamber. This will expose the box-like heavy plate steel upper baffle plate. This baffle is held in place by bars in its sides which are slotted inside support bars on the roof of the firechamber. Pull the lower baffle towards you to release



the bars from their supports and, as the baffle is released, lower it down from the back of the stove so that the front support plate on the baffle clears the airwash ledge at the front of the stove. The upper baffle is very heavy so be prepared to support its weight with two hands. It is part of the stove's Ecodesign low emissions combustion system and is designed to provide precise control over the flow of combustion gases and can therefore be a tight fit when the stove has been used in which case you may need to use a wooden or plastic

mallet to gently tap it free. Check the baffle for wear and use a soft wire brush to remove any soot deposits from both the baffle and around the flueway. If the baffle needs replacing a genuine replacement can be obtained from your authorised Hi-Flame dealer or from www.hi-flame.co.uk. **Please note** in line with all stove manufacturers vermiculite panels, baffle plates and other internal components are regarded as consumable items and are therefore not covered under your Hi-Flame Warranty.

Stove and Chimney Cleaning

This stove can be swept through the fire-chamber by simply removing its two baffle plates – see above. The chimney should be swept before installing the stove and then a minimum of at least once a year depending on how often you use the stove – this should preferably be when you stand down the stove for the summer.

The amount of soot deposits removed each time the stove is swept is a good indication of how often you should sweep the stove and, as you begin to understand your stove and the wood you burn, you can then adjust the cleaning intervals accordingly. If in doubt seek the advice of a registered chimney sweep who has experience of sweeping stoves.

Vermiculite Firebricks and Panels

Regularly inspect the condition of the vermiculite panels used for the firebricks, firebed and lower baffle plate. Please note that some minor wear is perfectly normal due to the high temperatures created inside the stove but replace any of these if the surface has been eroded by 20% (approximately 6mm) or if any damage exposes the stove's bodywork. Cracked bricks can still be used providing they still cover the bodywork.

To replace a firebrick, first remove the lower baffle plate by pushing this up and then

dropping it down to manoeuvre it out of the firechamber. There are two loosely fitted side firebricks, which once the upper baffle has been removed, should be easy to remove and this will then release the back firebrick as well as the firebed panels. They should be returned in the correct reverse order. **Please note** vermiculite heat reflecting panels are deemed as 'consumable' and are therefore not covered under your Hi-Flame Warranty.

Heat Resistant Glass Maintenance

Using unseasoned or wet wood, small fuel loads or operating the stove at low temperatures (slumber burning) is not recommended and will reduce the effectiveness of the Airwash system causing the glass to stain. Do not allow such staining to build up as it may become more difficult to remove after each firing. When used regularly, a proprietary scratch-resistant stove glass cleaning gel or spray, which can be supplied by your stove dealer, should be sufficient to keep the glass in pristine condition. Make sure the glass is cold before you apply such cleaners, as applying a cold solution to hot glass could create a thermal shock within the glass causing the glass to crack. Always use a soft cloth to apply any cleaner. Make sure that all traces of the cleaning fluid have been removed and that the glass is thoroughly dry as any residue can be 'baked' on causing unsightly smearing.

Never use your stove if it has cracked or missing glass. Your Hi-Flame dealer can quickly supply you with a new piece of heat resistant glass should you ever need it – just let them know the stove name and model number. Only use heat-resistant ceramic glass as this is made to withstand temperatures of up to 800°C.

Remove the screws and sprung clamp washers from each corner and place them in a safe place. Always use the correct sized Phillips crosshead screwdriver and use releasing oil if

the screws prove difficult to remove. Be careful not to dislodge the ribbon seal. If this is damaged or more than a year old then always replace it completely. The resilience of a new seal will provide a much-needed expansion gap between the cast door and the glass clamp to help prevent the glass from cracking as it expands. New ribbon seal can be held in place with rope seal glue which will be available from your dealer. Lubricate the screws and holes and reverse the process, being careful not to over-tighten the screws and clamps in case you break the glass. Once the new glass is held firm and doesn't rattle in its frame then there is no need to tighten the screws further.

Please note ceramic heat resistant glass cannot be recycled. Your Local Authority should be able to advise you on how best to safely dispose of it.

Door Rope Seal

It is important that you maintain an air-tight door seal as this prevents unwanted air leaking into the firechamber and helps make the air control more effective in adjusting the heat output.

To check the door stove seal, when the stove is cold place strips of paper between the door and 'door frame' and close the door. If you have to pull hard to remove these or they tear, then you have an effective door seal. If any of these can be easily removed, or if they slide around, you will need to replace the door seal.

Always use protective gloves and face mask when you handle both the old and new ceramic rope and prepare the rope seal channel.

To replace the door seal, carefully remove the old seal and completely clean the seal channel of debris and old glue. Any bare metal should be resprayed with an approved heat resistant paint. Use liberal amounts of proprietary heat resistant fire rope glue to hold the rope in position and glue both ends to ensure a well-

sealed joint. The joint should be positioned in the middle of the top or bottom side channel.

The diameter of the replacement ceramic rope seal is 12mm and you'll need approx 1500mm.

Paint Finish

Your stove has been finished with heat-resistant paint and is very easy to maintain. Regularly remove any ash and dust from the stove surfaces with a soft cloth or brush and then finish off with a soft damp (not wet) cloth.

Repair any worn or scratched surfaces with a proprietary heat-resistant spray paint made specially for stoves and available from your stove dealer. Never use an aerosol spray on, or near, the stove when it is burning or it is hot and be sure to protect other surfaces from residue spray spots.

Replacement Parts

In the interests of your safety, only ever use genuine Hi-Flame replacement components which you can purchase from your authorised Hi-Flame dealer or directly from: www.hi-flame.com or for the Republic of Ireland www.hi-flame.ie.

THE DIRECT EXTERNAL AIR SUPPLY (DEAS) Ref BS8303 (2018)

IMPORTANT It may be, that despite installing with the DEAS, in order to avoid depressurisation and to ensure the safe operation of the stove, a dedicated air vent, as prescribed in Building Regulations Document J (or its equivalent) is the only solution to ensuring the necessary additional air for the correct operation of the stove where there is mechanical extraction. It is strongly recommended therefore that the installer makes the householder aware of this before any of the installation work proceeds.

Installer responsibilities

- All external air ducting as well as the inlet grille must be fitted strictly in accordance with these instructions which are intended to give clear guidance to the installer on the safe installation of the stove and its DEAS.
- The person installing the appliance takes full responsibility for a safe installation (refer to Approved Document J, BS8303 (2028) and the relevant Hetas Technical Bulletins) and must ensure that the installation complies with all relevant Building Regulations.
- The installer must fully commission the appliance, including undertaking appropriate spillage tests and flue draught measurements, to demonstrate and confirm the stove's safe operation with the room in its normal state and also with doors and windows closed and any mechanical extraction in the room and the rest set of the dwelling set at maximum operation i.e. worst case scenario depressurisation conditions.
- As already required by Building Regulations a CO detector(s) must be correctly fitted and the householder made aware of the

importance of regularly testing it.

- The householder should also be made aware that the stove should never be operated with the door open except when refuelling and this should always be kept to a minimum.

Direct air supply ducting requirements

- The external diameter of the DEAS inlet on this stove is 90mm (internal dia approx 86mm).
- Ensure that the internal diameter of the direct air ducting is at least the same size as the internal diameter of the DEAS inlet pipe.
- Do not reduce the diameter of the ducting as this will affect the safe operation of the stove. For fire safety reasons only use the appropriate metal or non-combustible ducting. Never use plastic ducting.
- The maximum recommended ducting length for the air supply to this stove is 1 metre. Longer straight lengths may be considered provided that the appropriate flue draught measurements and spillage tests are undertaken by the installer to ensure that this will not adversely affect the safe operation of the stove.
- Keep bends in the ducting to a minimum and avoid using bends greater than 60°. Ensure that there is a good air-tight seal between the ducting and the stove's inlet pipe. Use an appropriate weather-proof, non-closable, external vent grille.
- When selecting the location of the external vent grille you must ensure that it can be easily accessed so that it can be regularly checked for potential obstruction (eg foliage growth, dead leaves or snow drifts etc). Never use the stove if these conditions exist. Ensure that the external grille will not be subject to the adverse affects of prevailing wind which will affect the stove's performance.

SPILLAGE AND FLUE INTERFERENCE TESTS Ref BS8303 (2018)

Flue pressure requirements

The minimum recommended flue pressure for this stove is 12Pa. Provided the flue pressure reading is within the 12Pa to 18Pa range then the stove should operate satisfactorily – subject to any spillage test outcomes. Where the flue pressure is less than 12Pa appropriate steps should be taken to improve this.

TEST 1 Cold Conditions Spillage Test

This test is used to determine that a suitable flue draught has been established which will ensure that during the start-up operation, as well as refuelling, spillage does not occur.

1 Close all external doors and windows, as well as the internal door(s) to the room the stove is located in and ensure all closable ventilators (eg window trickle vents) are closed and all devices that extract air from the dwelling are turned off (eg bathroom, tumble drier etc).

2 Preheat the flue to establish a sufficient updraught by either lighting a small fire burning kindling or using a blow torch or electric fan heater.

3 Ensure that the stove's air-control is set to the maximum open position (slide right). Light a smoke pellet (preferably 5m3/30 sec) and place inside the stove firechamber and shut the stove door.

4 Check that all of the smoke enters the flue and none of it enters the room through any part of the stove, its connecting flue pipe or the external air supply duct joint.

5 Note: If smoke does enter the room then repeat stage 2 above. However, this time build a much greater kindling fire, or significantly increase the time the blow torch or electric fan heater is used to warm the flue so that an

improvement in the flue draught is generated. Again, light a smoke pellet and place inside the stove firechamber and close the stove door.

6 If the second spillage test still fails, then progressively open a window in the room where the stove is installed. If the flue starts to draw the smoke, then this will indicate that the stove has not previously been provided with sufficient air for the flue to function correctly and therefore a permanently open air vent, as specified in Document J (or equivalent), may be necessary to correct the problem. When the air supply has been corrected then repeat the previous tests.

7 If smoke continues to spill after opening a window, this would indicate a more serious problem (for example a flue blockage or insufficient flue height) which must be rectified and then the commissioning process repeated.

TEST 2 Hot Conditions Spillage Test (Refuelling)

This test requires a smoke match / pen and is used to determine that the flue draught is consistent between cold and hot operation.

1 Once the initial flue draught has been verified as sufficient, light a good sized fire in the stove according to the instructions in this handbook, using the recommended fuel load and air control position(s). Allow the stove to reach normal operating temperature before refuelling.

2 Close all external doors and windows, as well as the internal door(s) to the room the stove is located in and ensure all closable ventilators (eg window trickle vents) are closed and any devices that extract air from the dwelling are turned off (eg bathroom, tumble drier etc).

3 Open the stove door, and with a smoke match / pen (15 second burn time),

pass over the top and sides of the firechamber opening and observe and record if the smoke / combustion products are drawn into the chimney or spill back into the room. Once the smoke match / pen is extinguished, close the appliance door.

4 Next, open all internal doors which interconnect the room in which the stove is installed to rooms where any extraction fans are present and turn these on to the maximum setting and allow to run for ten minutes. Repeat the smoke match / pen test above and observe and record if the smoke / combustion products are drawn into the chimney or spill back into the room.

5 If this spillage test fails, then progressively open a window in the room where the stove is installed. Again using a smoke match / pen observe and report. If the flue starts to draw the smoke, then this will indicate that the stove has not previously been provided with sufficient air for the flue to function correctly and therefore a permanently open air vent, as specified in Document J or equivalent regulations, may be necessary to correct the problem. When the air supply has been corrected then undertake the same test.

6 Fit an appropriate flue draught testing device to the connecting flue pipe and re-light the fire as previously. Repeat the test(s) in points 1 – 4 above. Check that the flue pressure meets the 12Pa minimum.

TEST 3 Extraction Test

This test requires a flue draught / temperature gauge(s). This test is to ensure that Hi-Flame's recommended operational 12Pa flue draught pressure for this stove is met. In some cases spillage can still occur, so it is important to carry out other essential smoke spillage tests.

1 Fit a flue pressure and flue gas temperature testing device(s) to the flue of the appliance.

2 Close all external doors and windows, as well as the internal doors to the room the stove is located in and ensure all closable ventilators (eg window trickle vents) are closed and any devices that extract air from the dwelling are turned off.

3 Light the appliance and ensure the optimum operating temperature is reached (approx 240°C).

4 Record the flue draught and the flue gas temperature and confirm that these are within the Hi-Flame's recommended parameters.

5 Next, open all internal doors which interconnect the room in which the stove is installed to rooms where any extraction fans are present and turn all of these on to the maximum setting.

6 Run the extract system(s) for ten minutes, and then record the flue draught and the flue gas temperature. These should not be lower than the previous readings obtained without the extract system(s) running and should not fall below Hi-Flame's safe minimum 12Pa recommendations.

7 Once the tests confirm the satisfactory operation, remove the test device(s) and if required seal any test point aperture in the flue pipe.

Please note if at any stage during commissioning the flue draught reading taken differs from the recommended minimum 12Pa, then action should be taken to improve the updraught before proceeding with further testing.

Test results should be recorded on the Commissioning Report on page 37 as well as for any Hetas conformance.

COMMISSIONING

1 Confirm that all internal parts of the stove are correctly fitted, including the baffle plates and the firebricks. YES

2 Confirm that the door closes correctly and that the latch mechanism and door seals work to make an air-tight seal. YES

3 Ensure that the air control is fully operational and that it moves freely. YES

4 Confirm that all appropriate smoke and spillage tests have been completed. YES

5 Confirm that the flue draught tests have been completed and that the tested flue pressure is recorded here. Pa YES

6 Confirm that the safe operation of the stove and the importance of only using seasoned logs has been explained to the user. YES

7 Installations with DEAS: Confirm that the 'worst case scenario' flue draught interference tests have been completed. YES

Indicate the action taken to remedy any problem:

8 Confirm that the legal obligations of using an approved fireguard whenever children, the elderly or the infirm are in the vicinity of the stove have been explained to the user. YES

9 Confirm that the customer will receive a copy of this Operators Handbook. YES

10 Confirm that a CO detector with a minimum five-year lifespan has been fitted in accordance with the manufacturer's instructions and that the user is aware of the importance of regularly testing it. YES

11 Confirm that the Warranty Registration has been completed at www.hi-flame.com/warranty, including the contact details and registration number of the Hetas / INFO

installer or recognised competent person who carried out the installation. In Northern Ireland you will have to supply details of Building Control approval for the installation works. Without this information your Warranty will be limited to one year only. YES

Installer's Signature / Date

Stove Owner's Signature / Date

STANDING DOWN

At some point in the year you will not need to use your stove and taking care to clean it thoroughly then will save you much time and effort later. This is also a good time to have your chimney swept to prevent any soot deposits falling into the stove and potentially blocking the flueway.

- Remove the baffle plate and clean any deposits in the flueway above it (see page 31). Inspect the vermiculite panel for signs of wear and replace if necessary. Remember to protect the hearth and any soft furnishings and floor coverings from soot and debris during the cleaning process.
- Empty the fire bed of ash and thoroughly clean out the firechamber. Inspect all of the vermiculite panels including those in the firebed. Replace any that have become very thin or have crumbled to reveal the stove's metal bodywork. See page 32.
- Inspect the door rope seal. Replace if it no longer provides an air-tight fit. See page 33.
- Inspect the stove glass and thoroughly clean it using the appropriate stove glass cleaner being sure to remove any baked-on residue.
- Inspect the log retaining bars. If these are bent or warped it could be an indication of over-firing or the use of inappropriate fuels such as petroleum coke. Order genuine replacement components from your authorised Hi-Flame dealer or from www.hi-flame.com.

THE MOST IMPORTANT PART...

Ensuring there is some free movement of air through your stove and flue system will help prevent the build-up of condensation which could eventually damage the stove's components. Therefore, always leave the air control fully open, only closing down to 50% if a nuisance draught is being caused.

HI-FLAME WARRANTY

Your new Hi-Flame wood burning stove has been CE EN13240 tested in Europe to ensure that it meets UK and Irish constructional performance, emissions and safety standards. It has also been tested and meets the forthcoming 2022 EU Ecodesign efficiency and emissions regulations.

IMPORTANT: PLEASE NOTE

It is not the responsibility of Hi-Flame or their distributors to ensure that the appliance is installed and operating correctly at the time of the installation. This is strictly the responsibility of the stove owner and any complaints regarding the performance of the installation should be addressed to the stove dealer or the stove installer.

Hi-Flame offers the original retail purchaser a 1 Year Warranty with a further limited 4 Year Extended Warranty subject to the terms and conditions being met. To see the full list of Terms and Conditions and to ensure that your stove benefits from the Hi-Flame Warranty you must register it within one week of receiving it at www.hi-flame.com/warranty.

In the unlikely event that you need to make a claim under the Hi-Flame Warranty it must always be reported in the first instance to the dealer you purchased the stove from. The claim will only be entertained by Hi-Flame or their distributors if your stove has been registered on the Hi-Flame website and you follow the claim procedure above. You must also have complied with all of the Terms and Conditions outlined on our website. Your attention is particularly drawn to the requirement that your stove is installed by a competent installer (preferably Hetas Registered) and that the installation applies to the current Building Regulations.

ANNUAL SERVICE

In the interests of safety and efficient performance it is important that your stove is serviced on an annual basis in accordance with the instructions outlined below. The service should be carried out by a suitably qualified person such as your original approved installer, a Hetas or INFO registered installer or your authorised Hi-Flame dealer.

Your annual service is best undertaken at the same time as your chimney or flue system is swept. Ensure that adequate protection from soot and debris is given to porous materials such as the fireplace or hearth, as well as floor coverings and soft furnishings. Wear protective gloves and a face mask.

Carefully remove, inspect and clean the following:

- The baffle plate inside the roof of the stove
See page 31 on how to remove this.
- All vermiculite panelling from the sides and back wall of the firebox as well as from the fire bed.
- Remove all ash and debris and use a soft brush to clean the internal bodywork and vermiculite panels. Handle the vermiculite panels with care as they may become fragile with continuous use. Some surface wear is normal on the panels and these only need replacing when they are very thin or have crumbled to reveal the stove bodywork.
- Pay particular attention to any debris build-up in the flueway area and ensure that this is completely clear. See page 31.
- Re-fit all the internal parts.

Stove Glass and Door Rope Seal

- Check the glass for chips or cracks and the glass seal condition and replace if necessary. Thoroughly clean the stove glass on both sides. Check that the door seal continues to

make an air-tight seal and replace if necessary. Ensure that the new rope joint is also in the middle at the base of the rope seal channel. Replacement rope should be 12mm diameter. See pages 32 and 33.

External Bodywork

- All external surfaces should be dusted with a soft cloth or light brush.
- Examine all paintwork for signs of wear and re-paint these areas only using the appropriate heat-resistant aerosol paint. Warning: do not use the aerosol if the stove is alight or hot.
- Lightly oil the hinges and door locking mechanism.

Air Controls

- Lightly oil the air control mechanism from underneath with a light machine oil spray being careful to protect any stone or tiled hearth.
- When standing down at the end of the heating season the air control should be left on the open position (slide right) to allow some movement of air through the stove which will help avoid condensation and moisture building up inside the stove and flue system. This can be closed up to approximately 50% (slide left) if a nuisance draught is being caused in the room.

Flue Pipe and External Air Connections

- Check the flue collar and flue pipe for any crumbling or missing fire cement seals and where applicable check the external air ducting. Remove any failed seals and re-seal using the appropriate heat-resistant sealant.

Important: Spare Parts

- In the interests of safety only use genuine Hi-Flame replacement parts. See the back cover for details of Hi-Flame's spares service.

FIRST SERVICE

Additional work carried out:

Date
_____Next Service Due

Signed

Print
_____Dealer's Stamp or HETAS Registration Number

SECOND SERVICE

Additional work carried out:

Date
_____Next Service Due

Signed

Print
_____Dealer's Stamp or HETAS Registration Number

THIRD SERVICE

Additional work carried out:

Date
_____Next Service Due

Signed

Print
_____Dealer's Stamp or HETAS Registration Number

FOURTH SERVICE

Additional work carried out:

Date
_____Next Service Due

Signed

Print
_____Dealer's Stamp or HETAS Registration Number

FIFTH SERVICE

Additional work carried out:

Date
_____Next Service Due

Signed

Print
_____Dealer's Stamp or HETAS Registration Number

SIXTH SERVICE

Additional work carried out:

Date
_____Next Service Due

Signed

Print
_____Dealer's Stamp or HETAS Registration Number

SEVENTH SERVICE

Additional work carried out:

Date
_____Next Service Due

Signed

Print
_____Dealer's Stamp or HETAS Registration Number

EIGHTH SERVICE

Additional work carried out:

Date
_____Next Service Due

Signed

Print
_____Dealer's Stamp or HETAS Registration Number

NINTH SERVICE

Additional work carried out:

Date
_____Next Service Due

Signed

Print
_____Dealer's Stamp or HETAS Registration Number

TENTH SERVICE

Additional work carried out:

Date
_____Next Service Due

Signed

Print
_____Dealer's Stamp or HETAS Registration Number

NOTES

Purchase Date

Installation Date

Serial Number
(from bar code label / packaging)

Stove Dealer's Contact Details

Stove Installer's Contact Details

Notes eg Chimney Sweep / Log Supplier contact details etc

NOTES

hi-flame

OUTSTANDING ECODESIGN STOVES

www.hi-flame.co.uk

www.hi-flame.ie

HI-FLAME SPARES SERVICE

In the interests of safety, only use genuine Hi-Flame replacement components. Once you have identified the component you need you can order it from your authorised Hi-Flame dealer or at www.hi-flame.com or if you're in the Republic of Ireland www.hi-flame.ie.

PLEASE NOTE

Any issues with the performance of your stove that cannot be resolved through studying the Trouble Shooting section (page 25 to 30) should always be dealt with, in the first instance, by contacting the original installer of your stove or alternatively your stove dealer.

Hi-Flame Multi Fuel Stoves

Hi-Flame Fireplace UK Limited
Holmes Chapel Business Park, Manor Lane
Holmes Chapel, Cheshire CW4 8AF
United Kingdom

www.hi-flame.com / www.hi-flame.ie

© Hi-Flame 2024. All rights reserved. Booklet contents may not be copied in whole or in part without the prior written permission of the copyright holder.