

## VS 65

### VERTICAL MULTI-STAGE

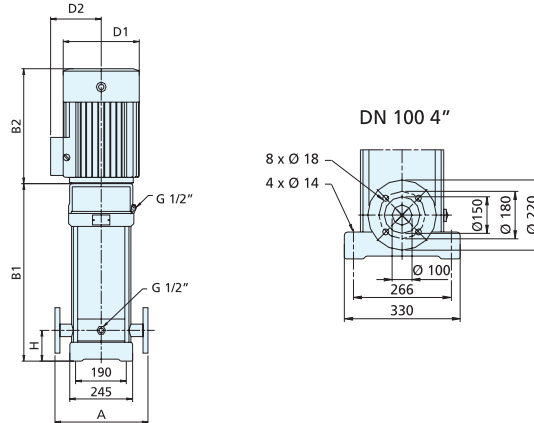
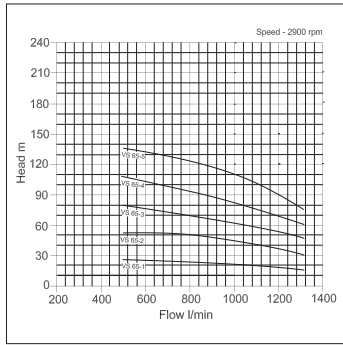

item code	model	flange/BSP	kW	volt	flow (l/min)	head (mtrs)	A	H	B1	B2	B1 + B2	D1	D2	weight (kgs)
19-15-1179	VS65-1	DN100/4"	5.5	400	1333	27	365	140	561	430	991	260	208	110
19-15-1186	VS65-2	DN100/4"	11	400	1333	53	365	140	754	490	1244	330	255	155
19-15-1070	VS65-3	DN100/4"	18.5	400	1333	80	365	140	836	550	1386	330	255	205
19-15-1044	VS65-4	DN100/4"	22	400	1333	107	365	140	919	590	1509	360	285	260
19-15-1181	VS65-5	DN100/4"	30	400	1333	136	365	140	1001	660	1661	400	310	345

PREMIUM EFFICIENCY MOTORS (IE3) AVAILABLE FOR ALL 400v MODELS (P.O.A.)

## VS 85

### VERTICAL MULTI-STAGE

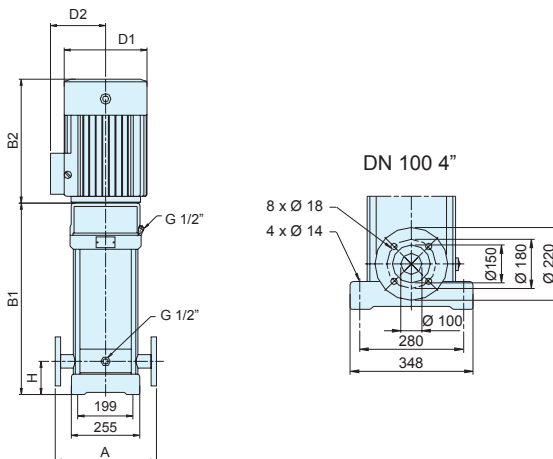
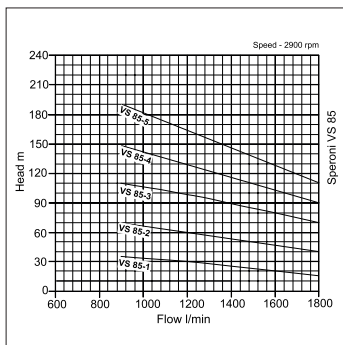

item code	model	flange/BSP	kW	volt	flow (l/min)	head (mtrs)	A	H	B1	B2	B1 + B2	D1	D2	weight (kgs)
19-15-1298	VS85-1	DN100/4"	7.5	400	1833	27	380	140	571	390	961	260	208	110
19-15-1301	VS85-2	DN100/4"	15	400	1833	53	380	140	773	500	1273	330	255	192
19-15-1303	VS85-3	DN100/4"	22	400	1833	85	380	140	865	575	1440	360	285	252
19-15-1305	VS85-4	DN100/4"	30	400	1833	110	380	140	957	650	1607	400	310	312
19-15-1307	VS85-5	DN100/4"	37	400	1833	135	380	140	1049	650	1699	400	310	336

PREMIUM EFFICIENCY MOTORS (IE3) AVAILABLE FOR ALL 400v MODELS (P.O.A.)